

# *A Tribute to Bob Pease*

Pease Porridge – 2 (1993-1995)

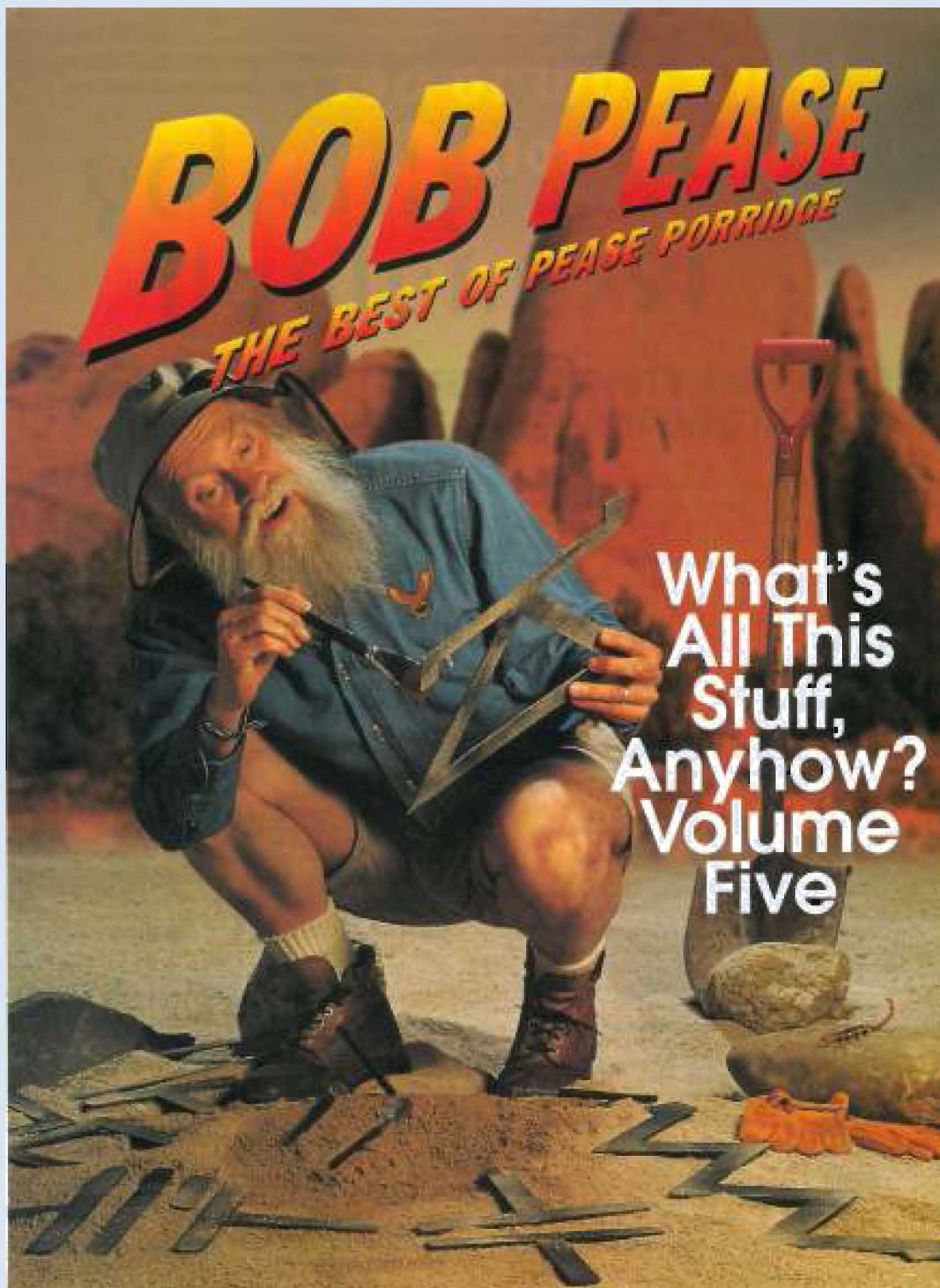

# WHAT'S ALL THIS CHECKLIST STUFF, ANYHOW?

**A**s you probably know, I like to go hiking and backpacking. I began hiking back in the '50s, and I started leading winter mountaineering trips in 1956 when I was 15 years old. Heaven only knows how I could lead a trip up 5798-foot Mount Adams in New Hampshire in March weather and keep us out of trouble.

But the weather wasn't too bad, and the other guys were reasonably intelligent, so we didn't do very much that was STUPID. We did not forget to bring too much equipment that we really needed...brandy, batteries for the flashlight and radio, toilet paper, matches, socks...



**BOB PEASE**  
OBTAINED A  
BSEE FROM MIT  
IN 1961 AND IS  
STAFF  
SCIENTIST AT  
NATIONAL  
SEMICONDUCTOR  
CORP.,  
SANTA CLARA,  
CALIF.

In 1961, I graduated from school, got married, and bought a car, and I was then able to go on LOTS of camping and backpacking trips. I soon found out that it was *easy* to get all the way out in the boonies and discover that I had neglected to bring any extra socks, or a scouring pad for cleaning the dirty pots, or the meat and cheese that I had put *very carefully* in the refrigerator. So I got really mad and made up a checklist of things NOT to forget. The key phrase at the top of my list is, "Circumstances will determine which items are optional; experience will dictate which items are essential."

I got our group's secretary, a very nice woman named Jeanne Finnert, to type this on vellum in her spare time. And I made many copies over the years on Philbrick's Diazo copier. Later I made Xeroxed copies of the Diazo copies. (Did I ever make a Thermofax copy of a Xerox copy of a Diazo copy? Probably not...)

If you have ever gone on a long hike and realized you forgot something, you *knew* you needed a checklist. Did *you* ever make up a checklist? Comments invited.

Anyhow, if you want a copy of my best backpacking checklist (I retyped it last year to include NEATLY several of the items that were added over the years), just send me an SASE. Or, if you have an old checklist *you* use, swap it to me for mine, no SASE required (but be sure to include your return address).

Example: I recently added a pillowcase and ear plugs to my list. If dogs are barking all night, you have a chance of getting to sleep.

And if you stow all your spare clothes in a plastic bag, you can *sort of* use that to cushion your head. But when it *crinkles* badly, you'll wish you had a pillowcase...

Now, after being in the industry a few years, I got dragged on various business trips. I soon discovered I needed a checklist of equipment to bring on a business trip. I drafted *that* in 1966, and updated it in 1986 and 1991. If you send me an SASE, I'll also throw that one in. I think it's a valuable kind of list. I mean, do *you* remember to bring CARBON PAPER on a business

trip? When on a trip, it's easy to start writing a memo at midnight, to be mailed at dawn, and you decide you want to make a photocopy, but then you realize that there is no time or place to make a photocopy. The old low-tech carbon paper can save you a lot of grief.

Do you check tires on your rented car? Do you bring scotch tape *and* masking tape *and* WIDE tape or duct tape?

That last one is good for all kinds of repairs, for example, covering up the locks on your suitcase in case the key is not available. I bet that I have at least eight other things on MY checklist for business travel that you don't have on YOURS.

One day I was making a copy of this checklist, and I passed around a few copies. One of the engineers grouched, "This checklist is a lot of garbage." Ten minutes later, he was observed striding briskly toward our Travel Office, muttering "Doggone, I nearly forgot to pick up my traveler's checks for my trip." (He was leaving the next morning.) So much for the concept that we do not need checklists.

Several people observed that I had omitted several important items from my list. Myself, I always carry a Swiss-Army knife with screwdrivers and bottle openers included. I never thought to put the knife on my list because I'm never without it. But, to be correct, it *should* be on the list.

My travel agent, Anne Raphael, who also hikes and camps a lot, had several suggestions and additions for my list, which I'm adding—tiny First Aid Kit, Dental Floss with a large needle, calculator, list of addresses and phone numbers of friends, etc. I'm not sure why they eluded me so long, but they're on there now.

Recently we began a movement to document, here at NSC, what elements of a design should be listed to be covered or mentioned or discussed at a Design Review meeting. No, I cannot send you a copy of that, because it is Company Confidential. And, NO,

**Circumstances  
will determine  
which items are  
optional.  
Experience will  
dictate which  
items are  
essential.**

# PEASE PORRIDGE

you do not need any checklist, so long as you can convince yourself to your own satisfaction that every new product has come out with no slip-ups MERELY due to somebody forgetting something. If your company can say that, it's either a very *smart* company or a very *new* one.

Anyhow, you have my PERMISSION and my ENCOURAGEMENT to make up *your own* checklists. And make sure enough photocopies are floating around, so that any engineer or technician or planner can suggest, "Oops, let's widen out that list, because we just got hurt by an item we forget to include on it."

All for now. / Comments invited!  
RAP / Robert A. Pease / Engineer

Address:  
Mail Stop C2500A  
National Semiconductor  
P.O. Box 58090  
Santa Clara, CA 95052-8090

P.S. This month I will compile my 23rd Annual Dead-Car List. To get one, send me an SASE. / rap

## BOB'S MAILBOX

*Dear Bob,*

Like you, my primary car is an old one — a 1969 Fiat 124 Sport Coupe that someone gave me a few years back. It is mechanically perfect, but desperately in need of replacement of its original paint. When I got it, the engine had little compression, so I replaced it with a new used engine.

Now it passes smog with flying colors and gets 30+ mpg on the highway at 75 mph. Coworkers wonder why I keep it, but the figures are sufficient justification. Besides, no one would ever steal a Fiat, and it hasn't been broken into either (knock on wood). My "good" car, a 1977 Lancia Scorpion (with a similar Fiat engine), also passes smog with flying colors, but it is not as fuel efficient as the Fiat. As long as you can still get parts for the oldies, and can keep them running clean, why change?

Besides, I can work on either car myself — the engines are not overly cluttered with smog equipment and the rat's nests of hoses and cables the

newer cars have.

By the way, it seems like the whole world is sending me copies of your column that featured my last letter, the one on the problems faced by the engineering technologist. I even got a copy from my cousin via my father.

I think you are doing the right thing by writing a column each month, rather than each issue. I write columns for a number of monthly newsletters, in addition to one entire bimonthly newsletter, so I certainly understand and appreciate the need for the mind to rest and accumulate data over a period of time. And I also enjoy the letters you print in the columns in between articles. Keep up the great work!

**MARK HUTCHENREUTHER**  
*Naval Surface Warfare Center*  
*Oxnard, Calif.*

*Not only do our old cars run fairly efficiently, but we avoid depleting the earth's resources by buying a new car before we really have to. — RAP*

*Dear Bob,*

In response to your Sept. 3 letter by "Name and Address Withheld" about technicians, I believe what he says is true.

I was an electronics technician for over ten years while attending engineering school part time. There are many good and better technicians working with (or for) good and not so good engineers, usually for much less pay!

The school I attended was a hands-on, real-world engineering school where you got your hands dirty and "learned" the practical side.

Today I am a supervisor of five electrical controls design engineers. The practical hands-on education and technician experience has served me well, something I don't see in younger, recent engineering graduates.

**C. H. FREY, SR.**  
*Electrical Controls Supervisor*  
*Modine Manufacturing Co.*  
*Racine, Wis.*

*The University of Hard Knocks is a good practical training ground for working on many kinds of problems. I like to have people with different kinds of wisdom on my teams. — RAP*

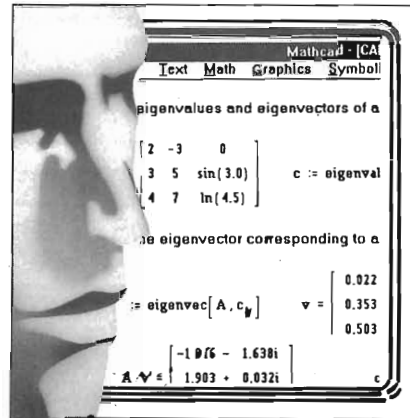

## COMPLETE MASTERY OVER TECHNICAL CALCULATIONS

**New Mathcad® Version 3.1...  
Fast, Easy, Accurate**

With new Mathcad Version 3.1, you'll do more math, more easily and communicate more clearly. It literally turns your computer screen into a "smart" math scratchpad.

- Writes and solves virtually any mathematical equation, numerically or symbolically.
- Easily prints out presentation-quality equations and graphics along with your explanatory text, to make you a more skilled communicator.
- Uses powerful Object Linking and Embedding (OLE) Client to directly interface with your spreadsheet, drawing, and word processing software.
- Allows "what if" calculating, so you derive better answers.
- Microsoft® Windows™ environment increases ease of use. Also available for Macintosh and UNIX.

Call **1-800-628-4223**

for more information and a free demo disk.  
Or call

**1-617-577-1017,**

or fax the coupon  
below to

**1-617-577-8829**



**YES!** Tell me  
more about  
Mathcad 3.1

Please send my FREE Mathcad 3.1  
Information Kit and Demo Disk to the  
address below.

Disk Size  3 1/2"  5 1/4"

Name \_\_\_\_\_

Title \_\_\_\_\_

Co./Inst. \_\_\_\_\_

Address \_\_\_\_\_

City/State/Zip \_\_\_\_\_

Phone (\_\_\_\_\_) \_\_\_\_\_

**MathSoft** Please mail this coupon to  
MathSoft, Inc., 201 Broadway,  
Cambridge MA 02139 USA



## PEASE PORRIDGE



# BOB'S MAILBOX

### Dear Bob:

Your column is a breath of fresh air. I am one of those non-degreed engineers who, like Rodney Dangerfield, "gets no respect" monetarily. I do, however, get a lot of respect from the young college graduates who I help to apply their book learning.

Some of us whose education comes from the school of "hard knocks" aren't just specialists. Besides my design responsibilities, I am my group's reliability and compliance engineer. I'm responsible for our EMC lab, and serve as a consultant to groups other than my own. You don't have to be a PhD to be respected by your peers. And it can be comfortable to be somewhat of an expert in more than one field in these unsteady times. Unfortunately, some people (prospective future employers?) put too much value on a piece of paper that does *not* say what you know, or what you can do.

Second Subject: You are right about a bicycle working with a small wheel. That experiment has already been done. According to one of the books I consulted when I first became interested in bicycles (about 20 years ago), someone did a study on wheel sizes and head-set angles. The size of the wheel is not important according to their experiments. The point of contact in relation to the axis of the head set is. If the axis of rotation for the fork is projected to the ground, the wheel's point of contact with the ground must be behind this point. Apparently they were able to reduce the size of the wheel to a chair caster, which is the same as your roller skate.

**MARK BALCOM**

Portland, Ore.

*I'm glad your group finds your experience of value. And, yes, many experiments have been done with strange bicycle geometries.—RAP*

### Dear Bob:

You have caught typos in some certainly prestigious documents (Oct. 15, 1992, *What's All This Czar Stuff, Any-*

*how?*), but you overlooked one in your own article. Third column, second line, the "a" is extraneous. However, you covered yourself very graciously in the next paragraph. Enjoy your articles immensely, please keep up the good work.

**W. P. DART**

Senior Engineer

Veda Inc.

Camarillo, Calif.

*Ah, yes, the computers put those typos in to keep Roger Engelke and me on our toes. We catch most of them, and let a couple through to keep you readers on your toes.—RAP*

### To whom it may concern,

This letter is a respectful reply to the article by Mr. Bob Pease, *What's All This Spreadsheet Stuff, Anyhow?* I believe the spreadsheet is one of the most popular and obviously useful applications to which a microcomputer can be put.

Bob Pease is a computer skeptic. He obtained his BSEE from MIT 32 years ago. First of all, Mr. Pease has a BSEE, while the majority of engineers today have doctorates. Mr. Pease is used to performing activities and calculations the long, hard way. In today's world, engineers and many other professionals are very busy and prefer to conserve time on simple activities in order to spend more time on more complicated problems.

I think he should accept the world for its changing technology, and thus join it. He should move forward at a faster pace. Mr. Pease also brings forth the arguments that spreadsheets get users out of the habit of thinking, and his new colleague Michael Schrage claims spreadsheet-like devices thwart creativity and imagination. On the contrary, spreadsheets and other such devices help speed up simple activities and calculations in order to give users more time to play with more complex work.

Mr. Pease believes that spreadsheets are unreliable because of the er-

rors he has observed with his experiences. I'd like to remind him of the fact that nothing in this world is perfect.

In conclusion, I believe that simple tasks performed by devices with time-saving abilities can only be advantageous to man. I respectfully advise Mr. Pease to catch up with the world. Spreadsheets are waiting for you.

**KEVIN N. FLINT**

Miramar, Fla.

*No, most engineers today do not have doctorates. And I got my degree from MIT 31 years ago. Where are you getting your facts, from a spreadsheet? Now since spreadsheets' "time-saving abilities can only be advantageous to man," I'll have to have a sex-change operation.—RAP*

### Dear Mr. Pease:

I'm writing this in response to your article about spreadsheets in the Aug. 20 issue. Your article really got me thinking about how we as a society have become so heavily reliant on electrical devices. We've gotten to the point where it's scary to think of what would happen to us if, God forbid, we didn't have electricity any more.

But the truth of the matter is that electronics is going to be around for as long as man can figure out new ways to make it work for him. Maybe it's true that electronics simplify and even oversimplify our lives in many regards, but is that really such a bad thing?

The answer is yes when it's used merely as a substitute for our lack of knowledge. An example of this is teaching a child to use a calculator instead of teaching him the times tables. In this case the calculator is the substitute for the child's lack of knowledge of multiplication, and if one day he forgets the calculator, then he would be absolutely lost. But it's important to note that the reason he would be lost would not be his lack of a calculator, but rather his lack of the concept of multiplication.

So, when and if the concept of multi-





## Just One Of The 50 Million Americans Who Invests In U.S. Savings Bonds.

Across the country, more and more Americans are planning for the future of their children by buying U.S. Savings Bonds. This Little League slugger gets a Savings Bond for each birthday. As he grows older, his Bonds grow in value. So he's not just getting a gift, he's getting an investment. Find out how U.S. Savings Bonds are making millions of American dreams a reality. Call 1 800 4 US BOND for more information.



**U.S. Savings Bonds**  
Making American Dreams A Reality

A public service of this magazine

## PEASE PORRIDGE

plication is understood by the child, then the calculator becomes a tool rather than a substitute for solving long and tedious problems that would take forever to solve by hand. In this regard, the calculator would be simplifying the child's life, but in a positive way, for now he could elevate his potential by elevating his resources.

If electronics would be used as a resource to accomplish a greater goal, then it would be simplifying our lives for the better. Inventions like the computer and the spreadsheet were meant to be used as resources for making problem solving easier. But to appreciate and utilize their worth, one must be open and receptive to advancement and change. It is by taking advantage of all our available assets that we have been able to grow technologically throughout history.

So Mr. Pease, the next time you lash out against spreadsheets, remember that much like you and I, they are not perfect and their sole purpose is to make our lives easier and save us a little time. So at least give them credit for doing that.

**MANUEL DOCURRO**  
*Hialeah, Fla.*

*I'm only cautioning you to CHECK your RESULTS, which spreadsheet peddlers never warn you to do. When a spreadsheet tries to "save us a little time," but errs, it wastes a lot of time.*  
—RAP

### **Response to Bob Pease:**

In his article *What's All This Spreadsheet Stuff, Anyhow?* Mr. Pease argues that, when misused, computers and particularly spreadsheets can be the cause of serious problems. I think he has a good point. Actually, I agree completely with it. However, I am opposed to the way he conveys his ideas. His writing style is not appropriate for the intended audience.

Computers are tools, operational aids that help people complete tasks efficiently. They should be treated like tools, because problems occur when they are not. If a person uses a computer without being "mentally involved" in the process, he is going to be unaware of the important aspects of his work. This situation leaves that

person with no basis for tackling an eventual inconvenience, while a person who uses a computer like a tool knows what he did and can recognize and correct any mistakes easily.

Mr. Pease tries to make the reader aware of this potential problem with computers, but ultimately fails. He fails because his sarcastic approach does not work. In the beginning, he describes computers as horrible machines that "make mistakes and lie a lot." This statement creates prejudice among the audience who are mostly computer addicts, or at least computer users. Prejudice prevents the readers from being objective and understanding the author's point. His arrogant tone also helps to annoy those readers, making it impossible for them to read his article impartially. I am sure that this will show in the responses written by some of my computer-lover classmates. Their papers will be loaded with criticism. The worst thing is that it does not come from disagreement with Pease's opinions, it comes from anger produced by some of his statements and illustrations.

The article does not work because the writer is not honest. He manipulates the information to serve his purpose. For example, he does not tell the reader that the round-off error done by the spreadsheet can be avoided by setting up the program previously. And he also excludes that the spreadsheet can calculate numbers with up to twelve decimal positions, four more than any calculator. The whole argument is based on incomplete or false facts, which are immediately recognized by computer literates, and they end up mocking the article...

**MATEO LONDONO ANGEL**  
*Miami, Fla.*

*Mateo, you say I'm prejudiced. But you have already decided that computers and spreadsheets are trustworthy and you refuse to concede that these problems really do occur. Companies lose serious business everyday because errors occurred and nobody ever questioned the spreadsheet's answers. If you like to pretend that's not so, that's your problem. My task is not to please everybody, but to wake you up. Looks like I almost succeeded.*  
—RAP

# WHAT'S ALL THIS COMPENSATION STUFF, ANYHOW?

One evening many years ago, I was sitting in a hotel lounge after a big Conference, drinking beer and talking with my boss Bob Dobkin and several other engineers, as well as some of National's marketing guys. The topic of different kinds of work came up, and after a while, the head of Linear Marketing, Brent Welling, said, "Well, Bob, suppose I asked you to come over to work for me in Marketing, for \$80K a year."

I drawled, "Gee, Brent, that's an intriguing offer, but why would I come to work for you just to take a cut in pay?" Now, at that



**BOB PEASE**  
OBTAINED A  
BSEE FROM MIT  
IN 1961 AND IS  
STAFF  
SCIENTIST AT  
NATIONAL  
SEMICONDUCTOR  
CORP.,  
SANTA CLARA,  
CALIF.

time I guess I was probably *not* making \$80K, but I can keep a straight face when I call somebody's bluff, and Dobkin can keep a straight face, too. Brent was so nonplussed that he shut up for more than 5 minutes. Heck, I hadn't ever seen Brent shut up for as much as a minute, so I guess I did a good hit on him. And all because the topic of compensation is such a taboo. (No, we're not discussing 30 picofarads, not today.)

These days, if I say anything about changes in my paycheck, I might be considered bragging about my income. Here's the point: If my salary is slightly more than \$56K, then one of my pay-

checks late in the year will *jump up* because the deductions for FICA\* are cut off when you have made that much money in a calendar year. But if your salary is *double* that, your paycheck will show an increase in July. So, even though I may feel *great* when my paycheck is unleashed from the FICA deductions, I can only brag to my wife about how good I feel on that payday. If I talked about how happy I am to my friends, they can all look at the calendar and compute what my income is. Everybody who makes a different salary (greater than \$56K) will have his paycheck jump up at a different time. However, in January, a lot of people will have their take-home pay decrease all at once. So even though we can't exactly celebrate our good fortune, we can all mourn the cut-off of our good fortune. Even our president Gil Amelio can join us in this disappointment.

Several years ago, I proposed to establish a new holiday to celebrate the rise and fall of income for anybody who makes more than \$56K, *and* for anybody who ever expects to. (I didn't want to exclude any wannabes.) Since we already have too many holidays around January 1, I proposed to position this holiday half-way between Labor Day and Thanksgiving, about October 15. I tried to interest Herb Caen, the excellent columnist for the San Francisco *Chronicle*, in the publicity for this new holiday. But he never showed any interest, so I let the idea drop.

Obviously, everybody likes to have some take-home pay. Even those of us who say, "I can't believe they are paying us to do this stuff, when I would do it almost for free...." are pleased when we actually do get paid. But then, there are many other sorts of compensation. Most engineers get pretty good medi-

cal insurance, and those who are self-employed would be quick to remind us that that's a pretty impressive fringe benefit. At National, we also get Dental insurance (about 90% coverage), eyeglasses, and eye care. We get some free life insurance, and the right to buy more at cheap rates. Now, I have not been sick enough to miss one day of work in at least the last 17 years, but that does not keep me from appreciating good health insurance.

What other kind of compensation do I get? Well, when I publish a technical article in a magazine, or every time I write a column, National contributes a chunk of money. They think it's better to invest money by encouraging the employees to write about how to design with our products, rather than just running paid advertisements. We can get paid between \$500 and \$3000 for an article, and that is *AFTER* taxes. So all of us engineers, and many technicians, too, feel a good incentive to write about new applications for NSC parts.

I'll name another area of "compensation": National has good parking lots. I don't know how it is where you live, but here in California, many companies, especially in urban areas, are required by anti-smog regulations to start to account for the value of parking privileges. If I drove in to work in San Francisco, and my boss decided to bribe me by paying my parking fees, that gets counted as income. But soon, a person who takes public transportation, or bicycles, or walks to work, can apply for an equal amount of extra pay, even though he doesn't pay any parking lot fees. And, in a short time, even companies like NSC will be required to either charge drivers for their parking privileges or give comparably-valued benefits to employees who do *not* drive to work. So, the whole area of "compensation" is really VERY complex these days.

How can we "compensate" some of the people who work for us? Well, we have to make sure they get a decent take-home pay. And we can make sure they get enough challenging work so they're not hopelessly bored. I mean, would I take a big raise in pay for a hopelessly boring job? (Hey, Brent, not even for \$80K.)

What do these needy kids have in common with excess inventory?



They are all going to college through EAL!!

**CALL EAL IF YOUR CORPORATION HAS MATERIALS AVAILABLE FOR DONATION.**

- EAL - Will take your donated material and use it to generate scholarships for needy, deserving students.
- EAL - Donations could mean an above cost tax deduction - IRS Reg. 170(E)(3).
- EAL - Scholarships are given in the donating corporation's name.
- EAL - Leverages your gift to help participating colleges.

For More Details  
Call 708-690-0010  
Peter Roskam  
Executive Director

**EAL**  
Educational Assistance Ltd.,  
P.O. Box 3021  
GLEN ELLYN, ILLINOIS 60138

## PEASE PORRIDGE

Other forms of compensation include when NSC employees want to buy National parts to build into their hobby circuits, they can get them at distributor prices—such as 4M DRAMs for \$12. And since we obviously want to encourage a guy to build a circuit that may turn into a good magazine article, we usually are able to get that guy sample parts for free. If he/she wants to come in on a Saturday, or take a scope or DVM home for the weekend, we can always find ways to get permission for that.

Just recently, NSC remodeled its cafeteria for quite a bit of money. The new food service provides inexpensive tasty meals, better than ever before. Because NSC subsidizes this, it saves the employee money, but the company gets the advantage that we can pop back to work quicker than if we went off to lunch at a restaurant. In a similar vein, we have some coffee groups that can put a Bunn-o-Matic in a convenient nook, with space and water and electricity provided by the Company. I won't say I never go over to the cafeteria to buy a cup of java, but usually I just throw 15 cents in a basket, grab a quick cup of Coffee Bob's best, and dig right back in to work.

So National puts a good bit of money in a given year into being nice to its employees. Is it direct compensation? Some is, and a lot isn't. But if you look at it as "enlightened self-interest," my employer tries to make life pleasant for us employees in many ways, and they do put a lot of money into it.

Am I trying to say that NSC is a great place? Well, I think it's a great and challenging place to work. Back 20 years ago, some of the toughest technical questions about op amps came in to Philbrick Researches, where I used to work, and we got paid well for answering them. These days, alas, Philbrick is no longer in business, and the tough questions come in to places like National. If we can answer the questions with a National part, then we deserve to get paid well for helping that customer. As near as I can tell, everybody at NSC is enthusiastic and cheerful and is willing to go out of his/her way to give the customer full satisfaction, even if it takes extra effort. And being compensated properly

helps us get in that enthusiastic mood.

National has a good Stock Option Plan. We can all pay a certain amount of our pay into a special interest-bearing account. At the end of each year, we can either buy stock at the price set a year ago—great if the price has gone up—or at a 15% discount if the stock has *not* gone up. I don't know *anybody* who doesn't appreciate this advantage. We also have a 401K retirement savings plan, where we can conveniently set aside tax-free money, and National even matches some of this savings. There's also a profit-sharing plan, which looks even better now that National is beginning to make a profit.

The Company Store offers photo finishing at very inexpensive prices, as well as assorted merchandise—watches, calculators, tee-shirts, and sportswear—I gotta go see what they are selling this week. We do NOT yet have a dry-cleaning establishment.

Of course we have strayed away from the original subject of *compensation*, and are also talking about "benefits," but it's pretty hard to draw a dividing line between them, unless you're a lawyer. For example, we have a pleasant 14-acre Employees' Park where we can picnic or jog on our lunch hour or on weekends. And NSC will pay the tuition for many kinds of educational courses.

I haven't mentioned every good or worthwhile topic. So, YOUR comments are invited. I will not invite every reader to write about how well they're paid or their amazing compensation packages. Rather, topics should be of general interest, and, as usual, some of these may show up in one of my Mailbox columns....

All for now. / Comments invited!  
RAP / Robert A. Pease / Engineer

Address:  
Mail Stop C2500A  
National Semiconductor  
P.O. Box 58090  
Santa Clara, CA 95052-8090

\*Who knows what "FICA" stands for? We know that our "Social Security" funds are technically sent through "FICA," but most people do not know that it stands for Federal Insurance Contributions Act.



## PEASE PORRIDGE



# BOB'S MAILBOX

### Dear Bob:

I have two points to make here.

One: You are absolutely right about spreadsheets telling lies or extrapolating false information. There've been several times I've used a calculator to check values only to find formulae in error. Spreadsheets are great for displaying historical financial data, but when we use them to predict the future, we're in very deep trouble. Perhaps that's why we're in such a mess regarding the national debt.

Two: Tantalum capacitors in audio. Enclosed are data I ran after reading your article. My business is professional audio. I don't believe what I can't measure, but with tantalums the problems are pretty apparent.

Tweakish, molecular audio types are a real cash cow for consumer manufacturers. Fortunately, in the broadcast and recording field there are far fewer tweak heads requesting exotic wire. Keeping product on the air or the client working is the order of the day.

However, the distortion produced by capacitors and op amps is significant when you consider the hundreds in the signal path from microphone, console, recorder, mixer, CD master, CD player, etc. The average solid-state-logic brand recording console contains about 1500 NE5534's!

*Mr. Kirkwood's curves show that if you let a tantalum capacitor get biased as much as 0.1 Vdc the wrong way, significant distortion can occur, both harmonic and intermodulation. This can occur with a signal as small as 2 V pk-pk at 20 Hz into a 10  $\mu$ F-10 k $\Omega$  high-pass network. You can avoid this distortion by applying a good dc bias to the tantalum capacitor. Or you can use an aluminum electrolytic, which gives less distortion in the same circuit.—Ed.*

**WAYNE KIRKWOOD**  
*dba Media Technology*  
Dallas, Texas

*I agree. If you know where to look, the errors are not unmeasurable.—RAP*

### Dear Bob:

After surviving a myriad of hiking and canoeing trips, it has become clear that a short checklist is best. This is especially true for "lug-it-yourself" trips in harsh terrain that last a week or two. Having said that, here are some unusual things from my two lists.

Do bring:

1) a Tyvek clean-room suit and booties for evening relaxation. These are great for mutant-mosquito infested areas like Alaska, Canada, or the Everglades; and they're also good as windbreakers. Don't forget netting headgear and some mosquito impermeable gloves (you won't need repellent).

2) two 3-ft.-long, 1/4-in.-diameter aluminum rods when hiking in desert areas. These can be attached with duct tape to your backpack frame and used as a shade support (bend to suit). Put that flap normally used for pack rain protection to good use and don't cook your head under a hat!

DON'T bring:

1) a Nerf football where marmots may be indigenous. They enjoy converting them into nesting material and aren't very concerned with the environmental impact of man-made material strewn everywhere. (They will also steal one smelly sneaker but invariably leave you the other one.)

2) more than five kohlrabi for personal consumption. Although they have a waxy skin that makes them last forever, you will get sick of them. I have placed kohlrabi out in the open at night but nothing seems to want to eat them. Put a kohlrabi in each sneaker and you may have an excellent repellent, but I won't guarantee it.

I'm also considering using the low space in the tubes of my backpack frame for regular or rechargeable batteries (perhaps with a small solar cell array for recharging?). You could power-up all sorts of accessories like a low wattage lamp, a radio, or an animal intrusion alarm. Oh, by the way, also bring several engineers on your trip

and you should have everything necessary for fun and survival!

**PETER H. SAHM**

*Sr. Member of Technical Staff*  
*Comlinear Corp.*

*Urbana, Ill.*

*Mr. Sahm: You say you prefer short lists? At least my list avoids Nerf footballs and kohlrabi: For Nicad recharging ideas, wait a couple months.—RAP*

### Dear Bob:

In response to your article, "What's All This Incandescent Stuff, Anyhow?," I am sending you a copy of the Engineering Specs from the Sylvania Miniature Lighting products handbook and catalogue. I have guarded this closely because of its contents which include: Theory of Radiation, Theory of Vision, Standards & Nomenclature, and Properties of Tungsten Filament Lamps. I have found this book very enlightening.

You have previously talked about measuring amplifiers and wanting to know how much "funny" they measured when they said their measurements looked "funny."

In your article, you said if you take a 115-V bulb and run it at 125 V your brightness is way up and the bulb life is way down. You also said that if you put a rectifier in series with the bulb, the bulb life is extended enormously.

In the catalogue, the nomograph on page 12 and the graph on page 15 show how much way up and way down and how much enormously.

For example, if you *increase* the voltage 20%, the current increases 10%, the candlepower increases to 190% (almost double), and the life expectancy goes down to about 12%. Likewise, if you *reduce* the voltage to 65%, the current drops to 78%, the candlepower drops to 23%, and the life expectancy goes to about 180 times the normal life of the bulb.

If you take this one step further and reduce the voltage to 50%, the current goes to 68%, the candlepower goes to

# PEASE PORRIDGE

about 9%, and the life expectancy goes to about 4000 times the normal life of the bulb. You might make a good hand warmer with this, but its reduced to the brightness of a night light.

You can carry bulb saving to extreme. How well can you see in the dark?

I guess we'll have to go back to candles. You can adjust the brightness of the candle by the size of the wick, the thickness of the candle, type of wax, put a little smoke on the inside of the mantle, etc.

As you said, you have to do a little analysis on what you want to trade off for efficiency.

I've always looked forward to your articles that involve a little critical thinking instead of accepting opinions or assumptions as facts. Keep up the good work.

p.s. The price on the current limiters from Digikey have gone up to \$1.45 in quantities of ten.

**D. LEON DISON**

**Communications Engineer  
Radio Communications Bureau**

*At V = 50%, the GE book predicts 18% candlepower rather than 9%. That's quite dim, but the eye can handle many octaves of range.—RAP*

**Dear Bob:**

I thoroughly enjoy your columns in Electronic Design. They get down to the bare facts and expand the use of engineering knowledge from the dry, esoteric stuff to stuff that can be used in everyday life. And they are fun to read.

In any case, I'm writing with regard to your column that appeared in the December 17, 1992 issue of Electronic Design concerning light bulbs. One issue I haven't seen addressed in utility-company propaganda that promotes the use of fluorescent-light-bulb replacements is the toll taken by turning the bulbs on and off. While it makes sense to use these bulbs in applications where the bulbs are not switched often, it seems that frequent switching will kill these expensive bulbs all too quickly in normal day-to-day use in a home.

So while we might be saving a few megawatts by not wasting energy in the form of heat, we'll be filling up the landfills with phosphorous and mer-

cury (not to mention spending lots of money) replacing these efficient bulbs. I haven't seen any data correlating the frequency of switching to the decrease in bulb life. Nothing is simple anymore. Any ideas?

Also, thanks for the explanation about the Capsylite bulbs. I used one in a reading lamp but was very annoyed by a slight flickering out of the side of my eye. Now I realize that the half wave rectifier you mentioned was responsible.

**GREGORY L. TUAI**  
**Seattle, Wash.**

*Your mother told you, don't turn off the light if you are going to be out of the room for only a short time. Your mother was right. For an incandescent lamp, "a short time" is 0.1 second. For a fluorescent, it's 3 minutes, because the start up has a definite wear-out mechanism. If you turn on a fluorescent lamp 3 minutes, 20 times a day, life would drop from 10,000 hours (28 years) to 5000 hours (14 years). But if you run it only 1 hour a day, the pay-back time is lousy for all those high-efficiency lamps.—RAP*

**Dear Bob:**

Thank you for your article on energy efficient lamps. My home is filled with X-10 type plug-in wireless solid-state lamp controllers, which cannot be used with fluorescent lights. I attempted to get around this problem with X-10 appliance modules that use an electromechanical relay as the switching element rather than a thyristor.

However, all X-10 modules have a feature whereby a lamp can manually be turned on by cycling its on-off switch several times even though it is in the off cycle of its timer period. The problem I found with fluorescent lights is that when they are turned off by the appliance module timer controller, the lamp arc or ballast surge resembles the signature, causing the module to turn on in response to manual switch cycling. Soon after the X-10 module turns off the fluorescent light, it turns it back on!

I had to return to mechanical clock-driven timers for fluorescent lamps. Halogen-IR lamps should solve that problem.

Finally, another candidate for en-

ergy efficient lighting is the "E-lamp" developed by Intersource Technologies, which uses radio frequency technology. These bulbs are reported to generate the light of a 100-watt bulb on 25 watts of power, and last 20,000 hours. I don't know whether they can also be used with X-10 controller modules.

**Charles Hansen**  
**Allied Signal - Bendix**  
**Eatontown, N.J.**

*I always wondered if there weren't some flaws in systems like the X-10 controllers. Halogens will help solve your problem. "E-lamps" are probably a couple of years in the future.—RAP*

**Dear Bob:**

In your column for November 12, 1992, you report that several readers question "... (now at 260,000), is it right to keep this old car running..."

I recall a college lecture to the effect that two-thirds of the energy ever consumed and almost all the pollution that an automobile ever produces occurs before it is ever driven. That is, the industrial processes that mine, mill, refine, and assemble an automobile dominate consumption and waste.

This suggests that the simplest way to reduce energy consumption and pollution is to require autos to last, say, thirty years rather than a self-destruct design limit of six-and-one-half years. In this context, your preservative instincts appear globally sound.

This would seem to have many interesting ramifications in terms of economic and social policy. For example, if cars are made to last five times longer than they do now, what does one do with the redundancy of capital and employment in that industry?

The demand for improved mileage seems to be aimed to reduce the political pressures on governments to maintain access to cheap fuels. The "cash for clunkers" business looks like a gimmick.

**Adam Fritz**  
**Afton, N.Y.**

*You've got a good point, but I think those proportions (2/3, almost all) are fishy. Who has facts? I'm in favor of reliability and longevity, but I don't want the government ordering me what car to buy.—RAP*

# WHAT'S ALL THIS BATTERY-POWERED STUFF, ANYHOW?

**W**hen I went hiking in Nepal in 1989, obviously I should have taken along a camcorder. But I didn't, and none of the other guys on the trek did either. I did bring a good 35mm camera and a small tape recorder, because I was well warned that many things in Nepal are very photogenic. I shot over 1000 slides. But, if I go on a trek like that again, a camcorder would be a very good thing to bring along. (I would still bring a small 35mm camera in my pocket, for landscapes and pictures with higher resolution than any TV).

But when I began to ponder the actualities, I realized that it would be very hard to get enough battery power to do even an hour a day of recording. So, when I bought a camcorder in 1991, I began planning how to bring the camera on a trek.

I bought the Sony TR-51 because it's quite compact and light at 1-3/4 lbs. (including strap but no case). It weighs less than my 35mm single-lens-reflex camera (Nikomart FTN, 2-1/2 lbs., including strap but

no case), and it isn't much more bulky. If one had to carry a bulky old 1989 camcorder that weighed about 5 lbs.—well, I refuse to think about that.

I will presume that a small 8mm or similar compact camera is the right

way to go. You can carry it easily and fire off a quick shot when you want. The TR-51 draws about 1 ampere from its 7-volt battery, about 7 watts.

Batteries... Sony's model NP-55 (about \$40) is good for 1 hour of steady recording, about 1 ampere-hour. But if you turn the camera on and off a lot, taking little snips of action and scenery, you're lucky if it lasts 40 minutes. Obviously, one of these batteries, fully charged, will barely last you about one day in a photogenic place like Nepal. The larger NP-77 (about \$60, 10 oz.) is good for almost double that amount, 1.8 ampere-hours. I have one NP-55 and one NP-77. So after the first 3 days in the wilderness, away from ac power, I will have to invent some kind of battery charger....

It's possible to put a set of five AA cells in a tiny little \$50 battery box sold by Sony. But they're *not* effective energy-wise in terms of weight or cost.

You could rig up five alkaline D cells in an extension-cord battery pack. That would be four times more effective than AA cells from the standpoint of weight and cost vs. energy. But after several days, you would need more D cells. Not cheap nor light. I bought a set of five rechargeable, sealed lead-acid cells. These are heavy and cost-effective, and would keep you in business about five days—but then they would run out.

So I needed some kind of battery-charging scheme. Solar cells would be much too bulky, and maybe too fragile? They're also unreliable on a rainy or cloudy day, and not easy to use if you're hiking through a forest. I mean, it's not easy to mount them on top of your backpack. Note, most solar-cell panels will inherently put out ZERO current if any portion of the panel is in the shade! But I do plan to buy one and check it out.<sup>1</sup>

A gasoline-powered generator would be gross overkill. Remember, an NP-55 (about 1 ampere-hour  $\times$  7V) is just 7 watt-hours, which is only about 1% of a horsepower-hour of energy. So a 1-horsepower gasoline generator would be absurd.

Frank Goodenough suggested, could you rig up a little model airplane engine to a tiny generator? That's about the right amount of horsepower, perhaps 1/10 horsepower, and the weight would be reasonable. But they're not very efficient; they would guzzle lots of fuel if you ran one half-an-hour a day. And the noise would not be acceptable, even after you added a muffler. So I do not see a solution down that alley.

One other possibility is if there are any decent, fairly compact camcorders that draw a lot less than 6 watts. I haven't looked into that, but I don't foresee much chance here for a really significant energy saving.

I asked my friends at work, but nobody had any good ideas about battery-charging. I have seen a portable radio with Nicads and a hand-crank generator.<sup>2</sup> You crank it up for a couple minutes and then you can listen for a half-hour. But this radio obviously runs on a lot less than 6 watts—probably down near 0.06 watts. Even if you rigged it up for additional output to an external battery,<sup>3</sup> it might not be at all suitable.

I spotted a little hand-crank generator, in an Edmund Scientific catalog, that could put out "10 V, 100 mA." The price of \$48 was absurd, but I decided to try it. When it arrived, it was a cheap little motor with flimsy plastic gears in a light but flimsy plastic framework. If you cranked it fast, the gear ratio was barely adequate, so you could just barely get 7 volts. And if you wanted to get 100 mA charged into a 7-volt battery, you had to crank almost at a frenzy. Bad investment. Not suitable for a battery charger.

Then a friend at work, Fran Hoffart, said he had a "gear motor." It had a 12-volt motor with an integral 65:1 gear box that he had bought for a couple bucks at the Electronics Flea Market.<sup>3</sup> I put a long crank arm on its "output" shaft and tried cranking. At about 30 rpm, a leisurely 2 seconds per revolu-



**BOB PEASE**  
OBTAINED A BSEE FROM MIT IN 1961 AND IS STAFF SCIENTIST AT NATIONAL SEMICONDUCTOR CORP., SANTA CLARA, CALIF.



## PEASE PORRIDGE

tion, I was able to get 200 to 400 mA into a 7-volt battery pack. Not bad! The gear motor weighs 1.2 lbs. (including crank and wires), which is not a trivial amount to add on top of your 45-lb. pack frame. But the alternative is to carry a 1.7-lb. camcorder that you can't use because its batteries are dead.

I strengthened the crank handle, hooked up some connectors and a little strap-on socket for the battery, and paid Fran \$5 for the gear motor. Then off we went on an 8-day backpack trip in the Sierras. To be honest, it took a lot of cranking to get much charge. I started the trip with both batteries fully charged, and after 4 days, both were pretty low. Still, with an hour of cranking, I could get an honest 1/3 ampere-hour into a battery, and that would be good for 15 minutes of intermittent recording.

And we always had a quiet hour in the evening when we would be sitting around sipping juices and nibbling snacks. So I could easily put in my hour a day of cranking, and that was enough to get some coverage of a day's events. I also was able to con my friends into helping out with the cranking. After all, how could I record their antics on tape if they didn't help bring up the charge on the batteries? So they helped, and grinned.

Eventually, I installed a good knob on the crank so I could easily crank at a good torque for a long time (just turning over the crank *easy* would put 100 mA into the battery, but if you want to get a good 300-mA output you have to crank with quite a bit of force). I rigged a spare piece of cord so the torque from cranking could be carried by a long lever arm and the cord itself to my foot (as I sat cranking), or to my neck (as I ambled along a trail). This cut out a great deal of the effort needed to hang onto the motor as I cranked. I found I could crank as I walked along easy trails. But if I had to do any serious hiking, it would be pretty hard to crank at the same time.

Still, if I went on a trek, I could crank an hour or two per day and keep my batteries charged up pretty well so that I could record a few dozen minutes every day. If I went to Nepal, I would pay one of the porters a few rupees to crank for an hour every evening. If I go

backpacking with friends, I can get my friends to chip in a few minutes, just for a lark. And they did enjoy helping on my recent trip, just like Tom Sawyer got his friends to help him white-wash the fence. SO, I think I have a handle (literally) on how to drag along enough batteries for a big trek. I would need 3 or 4 batteries, and a couple of chargers, and I'd have to put in some of my spare time. I might even have to do some cranking while I hiked on easy trails. But it WOULD work.

Where would you buy one of those gear-motor sets? Well, the one I got is made by The Pittman Co.,<sup>4</sup> and is rated at 12-volt dc with a 65:1 gear ratio. I peeked inside, and the gears do seem well-lubricated and well-designed for industrial service. I got a catalog, and this model is still available. The specs make sense. But the amount of torque I was putting in was excessive for the output gears.

So I ordered a similar gear motor with 38:1 gear ratio, GM9413-38:1. This is about as small and light as you can get for a gear motor that will put out 300 mA at 7 volts—anything smaller than that could not handle the torque (175 inch-ounces at 50 rpm) or the amperes.

What about cassettes? The VHS-compact tapes only run 20 minutes, so you would use up a pretty big box of them on a 20-day trek. The 8mm cassettes are compact and can record for 120 or 150 minutes, so 10 of them would last for 20 days (at 1 hour per day) and that's the same size as 10 audio cassettes—not bad.

Rain-proofing.... If you're out hiking and rain begins, a plastic bag or two can keep your machine pretty dry. If you wanted to take some shots on a rainy day, and it's not too windy, you can carry an umbrella. I tried that, and I was delighted to find it worked quite well. Or, for about \$150, you can buy a camcorder raincoat that lets you shoot through an optically flat glass while the camera stays perfectly protected from the rain. You just put your hand up into that bag from below. For about \$350, you can get a completely sealed version of a big heavy plastic bag with excellent waterproofing and an optically flat glass front panel, so you can take your camcorder diving with you

down to 30 feet deep.

I'll list the outfit that sells these<sup>5</sup>, because many camera stores won't know where you can buy them. Still, \$150 is a lot to pay for a plastic bag. But it's better than getting your camera soaked or doused with salt spray. I just brought some plain plastic bags and a zip-lock plastic bag, and I put on an extra UV lens to protect the camera's front end.

This camera is small enough (7-1/4 in. × 4 in. × 3-1/4 in.) to fit into a small water-repellent "fanny pack," so I can easily strap it around my tummy and bring it just about anywhere. The zipper is a minor annoyance, but it's not quite bad enough to force me to redesign it with a velcro cover (that would also have drawbacks). When it rained, my rain parka covered over the fanny pack, keeping everything perfectly dry but still accessible.

When we were returning home from Nepal, the Security Guards at Kathmandu Airport were very polite, but they confiscated a dozen AA-cell alkaline batteries from one of us. We later asked at several places, "Where does it say you should not bring flashlight batteries on planes?" (SMWISICDI)<sup>6</sup> We never did get a good answer. But recently a friend who travels a lot told me that in Korea and several other Asian airports, the Security people do confiscate flashlight batteries in your hand-baggage for fear of saboteurs using them to ignite explosives. So be sure to keep your flashlight batteries in your checked baggage—that is OK.

Of course, lead-acid batteries can be pretty dangerous, and they're normally forbidden on planes. But I found one company that sells lead-acid batteries for electric wheelchairs that are approved for airline travel.<sup>7</sup> So if you need larger batteries than ordinary Nicads or small sealed lead-acid batteries, that may be a good resource.

One other thing about your camcorder or portable computer—when you go to the airport, the security people like you to be able to turn it on and demonstrate that it really *does* work (not just a dummy packed full of dynamite). So make sure your batteries are charged up.

This is especially important if you are travelling outside the United

## PEASE PORRIDGE

States, because security in Europe and Asia is a lot more rigorous. Of course, this is contradictory to the premise that the airport security doesn't want you to carry any batteries. Ask your travel agent what to do!

Now, I have been talking mostly about charging problems for a camcorder. But in reality, if you have a lit-

tle portable computer, or radio, or transceiver, and you travel out of the United States or far away from line power, you will probably have similar problems. Maybe these ideas will be useful. Stay tuned for more!

All for now. / Comments invited!  
RAP / Robert A. Pease / Engineer

Address:

Mail Stop C2500A  
National Semiconductor  
P.O. Box 58090  
Santa Clara, CA 95052-8090

1. John Christensen suggests trying a solar panel, about \$60 for 14 V at 200 mA. I am ordering one from Solar Electric Inc., 1450 Harbor Island Dr., Suite 204A, San Diego, CA 92101; (800) 842-5678.

2. Crank-Dynamo AM-FM radio, about \$34. REI CO-OP, 20640 Homestead Rd. at Sunnyvale-Saratoga Rd., Cupertino CA 95025; (408) 446-1991.

3. The Electronics Flea Market is held on the second Saturday of each month from April to October, 6 AM to Noon, at Foothill College, Los Altos, CA at the Moody Rd. exit off I-280. Free entry for shoppers.

4. The Pittman Co., Harleysville, Pa. 19438-0003. Model "GM9413-3", 12 V, 175 in-oz., 65.5:1 gear ratio. About \$28 in quantities of 1-9. The same GM9413 gear motor with 38:1 gear ratio is preferable, because it can put out twice as much power without exceeding the gear box's maximum torque rating. Call (215) 256-6601.

5. Raincoat for rain and spray protection, Models E190, E191, E192 (depending on the size of your camera), about \$150; Ewa-Marine c/o Pioneer Marketing & Research Inc., 216 Haddon Ave., Suite 522, Westmont, NJ 08108; (800) 257-7742. Also, waterproof plastic-bag housing for down to a 30-ft. depth, Model E176 or similar, \$350. (These are actually manufactured by Goedecke & Co., Kirchheim, Germany.)

6. "Show Me Where It Says I Can't Do It," Pease Porridge, Electronic Design, May 9, 1991.

7. Mobilelectrics, 4311 Woodgate Lane, Louisville, KY 40220; (800) 876-6846. Deep-cycle, sealed-lead-acid batteries, \$69.95 plus UPS, "Airline Approved."



## Mix It Up With Our Logic Family.

Our TC74VHC 5V high-speed logic family adapts to either a 3V or 5V environment, so they're perfect for today's mixed voltage systems.

They save big on board redesign, too, because like all our VHC products, they use industry standard functional pinouts.

And with our SSOP packaging option saving up to 70% on real estate, they're right at home in notebooks and other small systems.

Call today for product literature on our entire TC74VHC product family.

When it comes to power, they can take whatever you dish out.

**1-800-879-4963**

In Touch with Tomorrow  
**TOSHIBA**

TOSHIBA AMERICA ELECTRONIC COMPONENTS, INC.

©1993 Toshiba America Electronic Components, Inc

LOG-93-008



# BOB'S MAILBOX

**Dear Bob:**

I was amused once by a professor of history when he made the comment that physicists are unique among the educated. He stated in jest that no matter how little they know about a given subject, they always have an opinion on it. Years after hearing this comment I still chuckle over it, but have found it to be true on several occasions. However, after reading Peter R. Vokac's two letters in your column (June 11, 1992, and December 3, 1992), I am beginning to think that this phenomenon may not be unique to physicists alone. At first I was hoping Mr. Vokac was just joking, but due to the nature of some of his comments as well as yours, I concluded that he was not.

To begin with, Mr. Vokac seems to be confused with terminology, the first of which are the terms "digital" and "discrete." Although I have noticed that some electrical engineers tend to use the terms "digital" and "discrete" interchangeably and synonymously, this is not the case from a mathematical point of view. "Digital" refers to a type of electronic hardware, whereas "discrete" refers to the mathematics that describe the signals processed by that hardware. Similarly, "analog" refers to a type of electronic hardware, but "linear" and "continuous" refer to the mathematics involved in that signal description.

If these definitions are to be accepted, then Mr. Vokac is certainly confused insofar as his terminology is concerned. For example, he implies that "time" and "clocks" are synonymous when he said, "Time is digital because all clocks tick." Just because clocks tick does not mean time is digital or discrete. Clocks are simply a measuring device, while time is the thing being measured. Clocks tick because that is the nature of their mechanism; the nature of the mechanism does not necessarily infer anything as to the nature of time. If Mr. Vokac's statement were true, then a potential difference is analog when measured

with a meter using a D'Arsonval movement and "digital" when using a digital meter. Even an undergraduate in electrical engineering can see the obvious fallacy in this reasoning.

Mr. Vokac did make a valid point when he stated that, "Acoustic waves are digital at the molecular level where they are a sequence of bumpings." This is true (if we substitute the word "discrete" for the word "digital"), as kinetic theory bears testimony. Fluids are no different. However, this is only true on the molecular level. On the macroscopic level (which is the world we live in), it is often impractical and totally unnecessary to discuss the individual motions of particles that have a population on the order of Avogadro's Number. Thus, a continuous approach is necessary and extremely helpful.

Mr. Vokac is still further confused by the relationship between mathematics and physical reality. This was evident when he was discussing photons in the December 3 column. The notion of wave-particle dualism exists due to our inability to describe the universe properly and completely. Sometimes it is proper to describe a photon as a discrete particle, as in the photoelectric effect, and sometimes it is proper to describe it as a continuous wave, as in diffraction and interference phenomena (Young's Double Slit Experiment is an excellent example of this). The description truly depends upon the context of the physical situation. The universe only provides answers that are as good as the question. If the question is not complete, the answer will not be complete, either. This is why the concept of wave-particle dualism exists.

However, quantum mechanics has been a highly successful area of physics, even if the questions that are asked are incomplete. The laser, elementary particle research, and nuclear weapons are living proof. It is unfortunate that Mr. Vokac does not find the statistical nature of quantum mechanics a "satisfying solution." This is also an interesting point. Mr. Vokac

seems to be ready to accept the statistical nature of Kinetic Theory (i.e., acoustical molecular bumping), but unable to accept the statistical nature of quantum mechanics. It must be noted that the two fields are intimately related and that they are also related to statistical mechanics. All of these fields have been highly successful and have predicted numerous new phenomena. Mr. Vokac has unwittingly contradicted himself.

For Mr. Vokac to say that a "new physical theory is just around the corner" is highly debatable. A new physical theory will in all probability only come into being when our present view of the universe becomes inadequate to describe any new physical phenomena encountered. Mr. Vokac's proverbial "corner" could be centuries away.

**JOHN LEWIS**

**Socorro, N.M.**

*Thanks for your efforts to critique Mr. Vokac's odd arguments about the "digital world." I tend to agree with your opinions. But, hey, I'm a physicist, too!—RAP*

**Dear Bob:**

Peter Vokac's letter was the most fun I've had in a long time except for one thing, it scared me. He belongs in politics, not electronics.

If he's "looking forward to the first invasion of digital wave-shaping circuitry into those arcane and untrammled bastions of analog design: Microwave and X-ray," he probably thinks Nyquist is a brand of snack cracker. He's got the cart before the horse. If he's working with a top of the line resolution color display, odds are there are already microwave-style transistors in the CRT gun drive circuits. (Let's see now, I need a high resolution color display to run Spice models to design the drive circuits for my new high-resolution color display to run Spice...)

Later on, I might question him, "If an optical, shadow projection of a rolling wheel in stress-less contact with a rail falls off, does the optical,



# PEASE PORRIDGE

shadow projection of the derailing train make a sound???"

But the best one was the revelation that photons are digital, but have strange behavior. (Under his theories, does that mean there are also five other types of photons?) He must have taken those college physics classes of long ago from Bohr himself.

Please Bob, tell me that he's really you writing under a pseudonym to insert a little levity. If not, to paraphrase an old English prayer, "Lord preserve me from the wrath of people who 'KNOW...'"

**FRANK R. BORGER**

**Instrumentation Section Head  
Dept. of Radiation Therapy  
Michael Reese Medical Center  
Chicago, Ill.**

*Honestly, I did not write Mr. Vokac's letter. Not even on April 1.—RAP*

**Dear Bob:**

I couldn't resist commenting on your claim that your VWs do not pollute any more than new cars. Don't think that I am against old cars; the newest car I have ever owned is the '79 VW convertible, which I now drive. I haven't yet had the bug emission-tested, but my '72 Mercury Cougar produces hydrocarbon and CO numbers very similar to those you reported in your November 12 column.

The problem is that hydrocarbons and carbon monoxide are only part of the story. They are relatively easy to keep at low levels, as our old cars demonstrate. The real problem is oxides of nitrogen ( $\text{NO}_x$ ).  $\text{NO}_x$  is a real bad guy, producing acid rain, and, by interaction with hydrocarbons, smog and ozone.

When the air/fuel mixture on a car without emission control equipment is adjusted to produce minimum HC and CO emissions,  $\text{NO}_x$  production is maximized. All that fancy junk on new cars allows them to move off of the  $\text{NO}_x$  peak by adjusting the air fuel mixture, then eliminating the extra HC and CO by "burning" it in the catalytic converter. Another way to reduce  $\text{NO}_x$  production is to reduce timing advance, coincidentally reducing the need for anti-knock agents like lead. The problem is that performance suffers. So, a bunch more fancy

equipment goes into trying to regain the lost performance.

$\text{NO}_x$  usually isn't tested because it is hard to test, and as long as the car has anti-emission gear in place and operating, and the car is tuned to factory specs (e.g., low timing advance), then low HC and CO measurements indicate low  $\text{NO}_x$  measurements as well.  $\text{NO}_x$  is produced mostly under heavy load, not just high rpm, meaning that the test stations would need expensive dynamometers to actually perform the test. Although I don't know of any states that test for it, the EPA does test  $\text{NO}_x$  on new car designs.

One of my excuses for keeping old cars running is that I do all my own maintenance and older cars are easier to work on. I never believe anybody that says new cars (even Japanese ones) never need work. It seems that it is always true "except for just that once or twice." The parts for older cars are also much less expensive. My old cars are increasing in value, or at least holding steady, while new ones depreciate. And I pay less insurance, and no interest on car loans. But from any environmental standpoint, my argument is: Look how much energy we save by not building another car, and look how much less junk that is in a landfill.

I have found that not only are old cars easier to diagnose, they also fail more gracefully (being that they're simpler). Several times I have made an old car limp home where a new one would have simply stopped. Often, the failure in a new car is traceable to some complex electronic gizmo in the engine compartment. One day my sister's new-ish Mustang simply stopped running as she was driving along. After a lot of effort on the mechanic's part (not me), the fault was traced to a 1-in.-square thick film hybrid performing an arcane function in the ignition system. Upon inspection under a microscope, I found that a hairline crack had developed in one of the conductors. Naturally, the whole module had already been replaced for \$55, and at \$40/hour.

VWs are about the simplest auto I have seen. I have noticed that there are more old VWs than other cars for sale in the local auto trader magazine, even taking into account their initially bigger numbers. I conclude from this that

they are (1) more reliable and/or (2) easier to fix than other cars. Does your research show that there are fewer of them Found On The Road Dead?

**DANIEL R. MORRIS**

**Project Engineer**

**Interpoint**

**Redmond, Wash.**

*Alas, my Dead Car List does not lead to any useful conclusions about the number of dead cars vs. the quantity of live ones on the road. And thanks for the explanation about  $\text{NO}_x$ . Most of us weren't aware of that.—RAP*

**Dear Bob:**

Your column of August 20, 1992, titled "What's All This Spreadsheet Stuff, Anyhow?" is accurate. My spreadsheet horror stories come from inspecting financial models of businesses. I certainly agree that people do not consider the assumptions the model makes, nor worry about risks. But even worse, the model is often based on getting the right output (profit) and adjusting the available parameters (costs) to achieve the "correct" answer. What is most appalling is that the people working on the model often fool themselves—a spreadsheet makes changing parameters easy, and after "playing with the numbers" for a couple of weeks often leads to faith in the answers that were the implicit input when the model was created.

My view is that a spreadsheet, like Lotus, is actually a very-high-level programming language. Unfortunately, many of the people using spreadsheets have never learned to program in any other language. Classes on spreadsheets cover the mechanics of using the tool and its commands, but never seem to address how to think logically about a problem. I do not blame the tool as much as the user. The worst problems with spreadsheets that I have seen are blatant programming errors, some of which have existed in important spreadsheets for a long time before being caught.

**DAVID WILSON**

**Workstation Laboratories  
Humboldt, Ariz.**

*Gee, your insights are good. We know that people twiddle with a spreadsheet to get an answer they like!—RAP*

# WHAT'S ALL THIS DOCTOR SCIENCE STUFF, ANYHOW?

**Y**ou're tuning your radio and suddenly you hear, "Plink-plink-plink-plink, Plunk-plunk-plunk-plunk, Plink-plink-plink-plink, Plunk-plunk-plunk-plunk...."

The plucky tune is joined by the voice of Rodney, who is Doctor Science's loyal assistant: "It's time once again to ASK Doctor Science....so, let's ASK Doctor Science...."

"That's me...." (the deep voice of Dr. Science).

"Remember, he knows more than you do...."

"That's right...." (Dr. Science again).



**BOB PEASE**  
OBTAINED A  
BSEE FROM MIT  
IN 1961 AND IS  
STAFF  
SCIENTIST AT  
NATIONAL  
SEMICONDUCTOR  
CORP.,  
SANTA CLARA,  
CALIF.

Now, Rodney announces the question of the day: "Bob Pease from Miramar, California writes in to ask, 'When I drive my car under big power lines, my radio doesn't fade out or buzz. When I was a kid and my father used to drive under the high-tension lines, the radio would fade out and then BUZZ. How come radios don't do that any more?'"

And Doctor Science replies: "Bob, they are just not making electricity like they used to. These days, electricity is so refined with alternators and voltage regulators, it just doesn't have the energy it used to—it's too pooped to buzz. In the old days, radios used vibrators to make very energetic volt-

ages—but, no more."

"Thank you, Doctor Science. Send your Science Questions to Doctor Science. Remember, he's not a real Doctor."

"I have a Master's Degree...."

"...in SCIENCE...." (Rodney chimes in)

"Plink-plink-plink-plink, Plunk-plunk-plunk-plunk.... Produced by Duck's Breath and distributed by American Public Radio...."

Every weekday at 10:50 A.M., I have programmed my computer to tune in to KCSM-FM, 91.1 MHz in San Mateo, Calif., to hear and record the mellifluous words of wisdom of Doctor Science. He's not a real doctor. He's nutty as a fruitcake. He gives answers that are sometimes marvelously intelligent, or marvelously stupid, or both.

And his 90-second daily radio column is JUST the perfect antidote to all of the serious science and all of the serious-sounding pseudo-science that we read and hear every day. Doctor Science has been broadcasting a daily dose of quasi-wisdom for over 10 years now.

I myself have collected about 40 hours of his tidbits on tape. Some are pretty awful, some are barely audible because my radio's reception gets goofed up, and some are just great. Here's some typical questions tailor-made for Dr. Science:

"Dear Doctor Science: After all these years of NPN and PNP transistors, when will I be able to get some of the new PPP and NNN transistors?" I just sent this one in, and am eagerly awaiting an answer.

"Dear Doctor Science: At restaurants, pasta and antipasto are usually served on separate plates. If they were

served on the same plate, would they annihilate each other?"

"Dear Doctor Science: What will the banks do in 1999 when they can't just print 19\_\_ on their checks?" Now, that IS a good question.

"Doctor Science" is really Dan Coffey, along with his loyal assistant Rodney (portrayed by Merle Kessler, who's best known as the fast-talking radio personality Ian Shoales), both founders of the Duck's Breath Mystery Theater. They have had several productions on television, including "Doctor Science's National Science Test," a PBS special. Duck's Breath also made a movie, *Zadar, the Cow from Hell*, which may be released on video later this year. Coffey and Kessler have also authored *Doctor Science's Big Book of Science*, a terrific collection of science-related humor and foolishness and pseudo-science, and old photos with great captions. Right now this book is all sold out, a collector's item, but it should be back in print again soon.

Even better, William Morrow Co. is scheduled to publish a new Dr. Science hardcover book this fall. You can call a toll-free number—(800) 989-DUCK—to get a free catalog and complete information on how to buy some of Dr. Science's excellent cassettes, or a SmugMug with "I KNOW MORE THAN YOU DO" emblazoned on the side—it's great to bring to meetings. You can even order a blank Master's Degree (in SCIENCE) and hang it on your wall, or give it to a friend to fill in his own name.

I also got a list of all the 100 public radio stations that carry the Doctor Science program. The show is available to nearly all public radio stations, so call the nearest one and ask when Doctor Science is on.

If they tell you he is *not* on, you can make a personal appeal to the program director. Tell him they are missing out on Good Stuff. If you inquire at (800) 989-DUCK, they can tell you which station in your area does carry his program.

I've been listening to Doctor Science for years. I began recording his blurbs every morning, after my old friend Tom Murray came to visit. He found

## PEASE PORRIDGE

that he could not get Doctor Science on the air back east. Apparently there are some stations that have been horrified by the irreverence of his non-scientific statements. These pompous, humor-impaired people seem to take themselves so seriously that they think kids will get the wrong idea. Sigh! I mean, what's wrong with:

*"Dear Doctor Science: What's wrong with being left in the lurch?"*

"A lurch is a large two-wheeled cart that is constructed of animal dung, and is used in Ethiopia as a get-away car for bank robberies and gang warfare. If your friends all pat you on the back and usher you into an old cart that smells like manure, and then they tell you they are going into a bank, and they'll be right back, maybe they are not such good friends after all..."

Daniel Dolman from Bloomington, Michigan writes, *"Dear Doctor Science: Often, in computer documentation, one will find pages with the statement, 'This page is left blank purposely.' Why do they do this?"*

"To waste paper. You see, the people who write computer manuals are nearly illiterate. To them, language is numbers and one-word commands. Their idea of casual reading is proof-reading the phone book, or pages of random numbers. Consequently they're out of touch with the rest of us, and this brings on feelings of isolation, and in many cases, paranoid delusions of persecution. So they fight back, first by wasting paper. If this venting of the spleen is left unchecked, they'll eventually move on to writing naughty limericks, and libelous statements about company management. If you have the time, write to the company and blow the whistle on this guy. You'll be doing everybody involved a favor."

"... thank you, Doctor Science..."

*"Dear Dr. Science: If sound can't travel in a vacuum, how come vacuum cleaners make so much noise?"*

And Dr. Science replies, in a reassuring way: "Vacuum cleaners are, in themselves, silent. What makes the noise you find so offensive are the actual particles of dirt and pollution in the space being cleaned. Now if your living room were clean when you vacuumed, then your vacuum cleaner would make no noise at all..."

"The flaw in all this, of course, is that if your living room was clean, you wouldn't be vacuuming. Since there is no such thing as a perfectly clean living room, scientists had to prove this hypothesis by vacuuming in outer space, which is both a perfect vacuum and incredibly clean. Astronauts reported that even the most powerful, poorly maintained vacuum cleaners made absolutely no noise in space because there is no dirt there. Millions of your tax dollars went toward proving this."

Now, when you read these little stories, there is some good humor in them, but when you hear Doctor Science tell the story over the radio, with his voice meandering back and forth between sincerity and sarcasm, it's really a treat!

*"Dear Dr. Science: Recently I was browsing through my local used-book store and saw an issue of 'Popular Science' from the early '50s. The front cover showed people flying around wearing rocket packs on their backs. Underneath the picture it said, 'Earth, 1990'. Now that it's 1993, where are the jet packs?"*

And the authoritative voice of Doctor Science replies, "Well, I have mine... what did you do with yours? Perhaps you weren't paying attention a few years ago when Sears put them on sale at half price, with four refill solid-fuel boosters and afterburners included."

"In fact, I bought the whole lab crew their own, and we spent a few days doing nothing more than zipping around the parking lot, banging our heads into walls and skinning our knees when it came time to land. So don't criticize progress if you can't take the time to read the ads in your local newspaper. Frankly, it's people like you who put the geniuses behind quadraphonic sound out of business."

*"Dear Dr. Science: What do protons and electrons do for a good time? Where do they do it?"*—Party Animal, New Orleans.

"Electrons go to any popular subatomic particle bar to meet protons. Being negative by nature, they consume large amounts of alcohol in a vain attempt to charge themselves up. What happens after that is none of my

business. Protons, being many times more massive than electrons, frequent trendy spas and gyms. These places, they find, are a good place to show off what they want other charged particles to see."

"Meanwhile, uncharged particles—neutrons and neutrinos—also have their own gathering places, although they're often the victims of harassment by immature particles who are insecure about their own valence."

*"Dear Dr. Science: Why can't you divide by zero?"*

"I don't know about you, but I can and often do divide by zero.... but only after I've taken the proper precautions. First of all, I fast for 48 hours, consuming only mildly fluoridated water during that time. Next I don a special Mylar/Teflon suit and put on a digitally recorded CD of Gregorian chants."

"I begin by dividing very small numbers by other very small numbers. As the numbers get smaller and smaller, the sparks begin to fly. If all goes well, I take a deep breath and divide a very small number by zero."

"There's a flash of light, a muffled roar....and when I come to, the lab is filled with smoke and the scent of burning Mylar. So you see, you can divide by zero if you really want to. But chances are, you just don't want to badly enough!"

Over a month's time, you'll likely run into several other comments by the good Doctor on various ontological and psychiatric aspects of science. Personally, I enjoy the ones that start out, "Pease, I'm appalled by your ignorance," or, "If you did THAT, that would cause the end of life as we know it..." I wanted to find a good example in my tapes—couldn't find one—sigh!

Dr. Science is also available, for a reasonable fee, to come to your site and provide words of wisdom. His "lectures" are excellent, and when you toss him a hot question, he can field it and, in real-time, throw you back an answer that's really impressive. When he was living in San Francisco, we engaged him to come down and lecture us at a big picnic at NSC, and we were impressed. (But now he lives in Iowa, and travels to the coasts occasionally.)

What Dr. Science really would like





**THIS  
PUBLICATION  
AVAILABLE  
FROM UMI**

This publication is available from UMI in one or more of the following formats:

- **In Microform**--from our collection of over 18,000 periodicals and 7,000 newspapers
- **In Paper**--by the article or full issues through UMI Article Clearinghouse
- **Electronically, on CD-ROM, online, and/or magnetic tape**--a broad range of ProQuest databases available including

abstract-and-index, ASCII full-text, and innovative full-image format

Call toll-free 800-521-0600, ext. 2888, for more information, or fill out the coupon below:

Name \_\_\_\_\_

Title \_\_\_\_\_

Company/Institution \_\_\_\_\_

Address \_\_\_\_\_

City/State/Zip \_\_\_\_\_

Phone ( ) \_\_\_\_\_

I'm interested in the following title(s): \_\_\_\_\_

\_\_\_\_\_

\_\_\_\_\_

\_\_\_\_\_

UMI  
A Bell & Howell Company  
Box 78  
300 North Zeeb Road  
Ann Arbor, MI 48106  
800-521-0600 toll-free  
313-761-1203 fax



## PEASE PORRIDGE

is a corporate sponsor. Public Radio fees barely keep the program afloat. For a very reasonable fee, an electronics or computer or high-tech company could get great name recognition and/or product recognition by sponsoring the Dr. Science program. "If we could find an enlightened sponsor that doesn't mind marketing with its tongue in chic, they'd have a terrific deal," says Steve Baker, the series' executive producer. "They would reach an upscale professional audience, in an uncluttered drive-time atmosphere." Any serious corporate interest can reach Mr. Baker at 800-989-DUCK.

Meanwhile it's appropriate that this program is "...Produced by Duck's Breath," because if Doctor Science isn't a heck of a fine QUACK, who is??? And if you have any good questions about SCIENCE, or comments for Dr. Science, send them to me and I'll forward them to him.

All for now. / Comments invited!  
RAP / Robert A. Pease / Engineer

Address:  
Mail Stop C2500A  
National Semiconductor  
P.O. Box 58090  
Santa Clara, CA 95052-8090

P.S. One good idea that I wanted to do for an April Fool's issue is to write a column on Hoaxes. Not just spoofs or jokes, but REAL hoaxes in the electronics engineering field. Myself, I do not yet have quite enough stories to make a full column. Yes, I have info on the Tice Clock, and, yes, I have the digital system for burning in speaker cables. And YES, I have the company that proposed to fit in several digital bits after the end of one cycle of an RF signal, and before the start of the next cycle, and get more information across without requiring extra bandwidth. Yes, I will even mention the Signetics WOM (Write-Only Memory), although that was more of a spoof than a hoax. And the BD-1 Battery Discharger IC. But if you have any good stories of Hoaxes, send them to me and we'll do a good Column for *next* April.



# BOB'S MAILBOX

**Dear Bob:**

This letter is in response to your August 20, 1992 article titled "What's All This Spreadsheet Stuff, Anyway?"

There is nothing wrong with the Spreadsheet! The problem is with the user of the spreadsheet. Back when we trained our engineers to use slide rules for their calculations, the first thing we learned was about accuracy. We all learned how to do complex calculations but understood the limits of the slide rule's accuracy.

Unfortunately, in business school there is no caution about the accuracy of the trusted spreadsheet. The problem with the spreadsheet is less with the tool than the person using the tool. The spreadsheet is an outstanding tool when put to use by a person who understands the limits and proper application of the tool.

**V.A. CLAUDE**

**Orlando, FL**

*Yeah, nobody does a sanity check on their computers—sigh!—RAP*

**Dear Bob:**

I do not quite agree with your views about spreadsheets. I have been using spreadsheets (computer spreadsheets) for the last 5 years and I have found numerous uses, which could not be done by hand calculation. The following are some examples.

To look at parametric distributions of a particular product, frequency distributions and trend charts can be produced very easily by using spreadsheets. These by the way, give a precise picture of what the product does, and this can not be seen by just looking at numbers. To fine-tune a process to get optimum performance and yield, such data is not only useful but necessary.

The distribution plots and trend charts make a lot of business decisions very easy, and no one's personal judgment and experience is necessary. The data speaks for itself. The distributions can also be used for competitive product analysis, which tell you ex-

actly where you stand with your competitors. This type of data analysis gives you a direction for improving the product to make it more competitive or even to set goals for new products.

The statistical data analysis becomes very easy with the use of spreadsheets. Pareto analysis of failures points to the most critical problem and also indicates all other problems in order of importance. The simple data sorting of failure categories would be an enormous task if one wants to do it manually. Also, the facility of importing data from automatic test equipment simplifies the analysis process. The Paretos are not only useful in technical analysis, but in business planning as well. The volumes of numerous products can be compared at the same time and forecasts made based on the facts. The products that are not selling well are also identified at the same time, and the sales force can be given the directive to focus on those. The same technique can be used to monitor expenses and control spending on all of the things involved in managing a business.

Thus, there are plenty of very good uses for spreadsheets, in technical as well as business areas. And spreadsheets do not endanger corporate health at all. The complaint in your article could be applied to any machine. We must remember that machines can not think. If a human being makes a mistake, they will repeat it or may magnify it. But, there has to be a human error involved. If there is no human error, there is nothing to complain about—but there is a lot to benefit from today's machines (including computer spreadsheets).

**ABHIJIT TULPULE**

*Oh, yes, you are surely right, spreadsheets do things that otherwise would be ABSOLUTELY IMPOSSIBLE; no judgment necessary.—RAP*

**Dear Bob:**

I always enjoy your column and have been tempted to stick my oar in before now. But I don't see how I can let this

Spreadsheet subject go by without some comment.

First, your examples concerning ROI and frequency optimization bring just one word to mind: GIGO. Sure, you can get incorrect answers with a spreadsheet—but I can get answers, probably even MORE incorrect, with pencil and paper. Let's not blame the poor spreadsheet because someone feeds it garbage.

Second, what kind of accuracy do you get from a slide rule? Better than a spreadsheet? What KIND of spreadsheet?

Finally, you are right about the spreadsheet only thinking (my apologies) linearly. Computers in just about any application aren't worth a toot at being creative, which sounds like what you and Schrage were talking about. But be reasonable—my hammer doesn't do a real good job of removing chips from a circuit boards, either, but I still find uses for it—! Maybe it's a question of the right tool for the right job...

Keep the columns coming!

**BILL AULL**

**Technical Director**

**WLTX TV**

**Columbia, S.C.**

*That reminds me of the old saying, "To a man with a hammer, everything looks like a nail." To a man with a computer, everything looks like—a computer problem!—RAP*

**Dear Bob:**

I read your article concerning spreadsheet mentality with great interest. What you have observed is considerably more significant than you may realize.

The spreadsheet permeated the real estate valuation industry originally as the Ellwood Method about 30 years ago and more recently (15 years) as Discounted Cash Flow Analysis.

A fundamental mathematical formula expresses the relationship of the three variables involved when valuing an income stream:

# PEASE PORRIDGE

$Y = R + A$ , where:

$Y$  = Discount or Yield Rate (annualized rate used to equate future income to present value);  $R$  = Capitalization Rate (rate of annual income);  $A$  = Growth Rate (rate of annual growth).

The appropriate Discount Rate for valuing an income stream equals the Capitalization Rate plus the Growth Rate.

Spreadsheet valuation programs let the user treat these three interdependent variables as if randomly independent. Once two variables are input, the third is, of course, determined.

If the Discount Rate is mathematically understated, or the Growth Rate is mathematically overstated, the value produced by the spreadsheet is mathematically inflated. In either case, the *present value* of increasing income is overstated.

Milton Friedman argues academically that the possibility of an exception (i.e. a property *could* outperform the market) means that the formula for valuation of an income stream is not necessarily hard and fast.

How would you like to be a stockholder in a Savings & Loan where *every* loan was predicated on the collateralized asset outperforming the market? This is what happened and half the Savings & Loans are no more.

There have been those in my industry who have specialized in such distortions, which is THE reason for the Savings & Loan crash.

Your observation was particularly interesting to one who has been making a similar argument in a seemingly unrelated field for the past twenty years.

**MICHAEL D. HARTNETT**  
*Tampa, Fla.*

*Yeah, everybody making the SAME assumptions and using the SAME spreadsheet—right or wrong—is scary all by itself! “Every loan must outperform the market”... Wow!—RAP*

**Dear Bob:**

You’ve done it again—written about something I just *have* to comment on even though I’m supposed to be doing real work.

I, of course, refer to your heroic efforts to maintain charge on your camcorder battery while in the field. Your

existing solution is ingenious and reliable, but an hour’s worth of whirring noise while sitting around a wilderness campfire must take a little bit of the charm out of the experience.

My thoughts are as follows:

1. I think you dismissed the option of using a set of D cells too quickly. Good Alkaline D cells have 14 Ah of capacity—about 3 to 4 times that of lead or Nicad. Although we need to confirm (by testing) whether you can draw 1 A from a D cell for the whole 14 hours, it seems reasonable to expect a week of shooting at one hour a day. A second set of cells will carry you for another week, at a total weight comparable to your generator set. A drawback, of course, is the extra wiring from your belt pack to the camcorder.

2. High rollers (like networks) are said to use primary lithium batteries, which should double or triple the life of alkalines. This option will probably not appeal to your penurious nature.

3. If you really prefer recharging the built-in battery, what about those thermoelectric generators the Soviet Army was supposed to have used? Campfires (or lanterns) are always available on camping trips, and this would be a silent and effortless option. I’m sorry I don’t know more specifics, but the modules used for automotive coolers might well supply useful power at a reasonable voltage.

4. If you aren’t already aware, the biggest problem in field use of camcorders is the prevention of internal dust and especially internal condensation. A “dew” episode will, at the minimum, trigger a protective shutdown that lasts an hour or more and may well drain your battery (the camera is supposed to stop and warm itself to drive off the moisture). Any attempt to bypass this protection will result in severe head clogging and tape damage (I spent several hours with the hair dryer on a cruise ship hand drying the tape inch by inch after taking my camcorder out of an air-conditioned cabin into Gulf Stream humidity, and misinterpreting the “Dew” warning as a low battery indication that I apparently overrode by changing batteries). While your treks don’t seem to feature air conditioning, cameras carried next to perspiring bodies can suffer similar

problems. Make sure your fanny pack is sweat-proof.

5. One more tip—are you *sure* you want an hour a day of footage? Even if it’s all gorgeous, consider how long it will take you to watch the final product; maybe you should be a little more judicious on the trail. I took almost 6 hours of footage on a truly unforgettable Orient Express train tour from Paris to Istanbul in 1984. It’s all good stuff but hard to show to anybody due to its length. You would have been impressed by my efforts. This was the pre-camcorder era—I lugged a portable deck whose “compact” camera alone was bigger than most of today’s camcorders. The train was advertised as using authentic ’20’s era cars, so I suspected that ac power might not be available. They did say that each compartment had a small fan. I built a “universal” charger using a capacitor to limit the current at 220 V ac to 100 mA, so I could get something off any ac voltage (primarily for hotel room use). However, I correctly surmised that the train’s lighting power would be dc, because old train cars used storage batteries recharged by belt-driven generators running off the wheels. Having thoughtfully provided myself with a meter, tools, and a dropping resistor, I determined that the fan was powered by 28 V dc and could readily be tapped at a screw terminal block, like the ones in your old VW. I was not only able to recharge my spare battery, but was able to power my “12-24 V” 7-in. TV, so we could see the “dailies” in the comfort of our compartment. A 16mm film crew had taken the trip earlier, and a network crew had made at least a partial trip, but I expect I was the first consumer video shooter to go the distance.

Good luck with your efforts—modern camcorders are wonderful memory-savers, although not as robust as film cameras.

**Patrick H. Quilter**  
*Vice President of Engineering*  
**QSC Audio Products**  
*Costa Mesa, Calif.*

*Thanks for the tip on alkaline cells. I’m investigating thermoelectric generators (heavy and inefficient?). I love your story of 28 V dc on the train!*  
—RAP

## PEASE PORRIDGE



# BOB'S MAILBOX

### Dear Bob:

I started reading your article "What's All This Incandescent Stuff, Anyhow?" in the Dec. 17, 1992 issue, when I came to a mention of an old college alumnus "who lives in Lompoc, Calif." I was immediately overcome by a severe attack of Lateral Thinking. Roger Ramjet! An ancient, tongue-in-cheek cartoon series that keeps recycling on our local TV.

I think the last episode I saw featured Roger Ramjet and his All-American Eagles (Padaahh!) rushing to the aid of the Lompoc Opera Company, who were presenting a season of Zucchini's opera 'Madame Butterfat' in between bouts of trouble with a mysterious Phantom.

They are always rushing to the rescue of somebody in Lompoc. The point is: I always imagined Lompoc to be a fictitious location. Surprise, surprise to see it mentioned in your column as a real place. What sort of place is it, I wonder?

Every state seems to have a "bend in the road" town that is lampooned on stage and screen. Ours is Eketahuna, which is actually on the main road from the Big Smoke to the Capitol. Strictly speaking, it was two bends in the road; one North and one South of the Pub. And very little else. How many bends has Lompoc got, I wonder?

Concerning the actual article, the technicalities of incandescent bulbs has always been of interest to me, especially the dramatic difference in cold and hot resistance. With cunning design, this can be put to good use to make the lamp act as an overload protection device for some other item—loud-speaker voice coils, for example. Or heater-current regulation....

**ALAN M. WOOLER, B.E.**

**New Zealand Association of Radio Transmitters Inc.**

**North Shore, New Zealand**

*Lompoc's a nice quiet town of 36,000, about 860 curves west of L.A. and 3400 curves south of S.F. (details later).—RAP*

### Dear Bob:

About a month ago, I wrote an essay on the current state of the art in artificial lighting, and yesterday I read your column about incandescent lighting. Such a coincidence!

After hundreds of years of artificial illumination, and decades of electrified homes, you'd think lighting technology would be a little less primitive.

I sit reading under a 60-W light bulb on a hot summer evening. The air conditioning is on, and the cool breeze keeps me comfortable. But soon the thermostat kicks the A/C off, and almost immediately I am aware of the heat radiating from the lamp. Doesn't this seem just a bit primitive? After all, why produce a lot of heat when what you really want is *cool* light? The waste is doubled when we must consume power to remove this excess heat from our homes with air conditioning.

The various alternatives to incandescent lights, in my opinion, all fall short of the ideal. Fluorescent lights have been receiving much promotion as energy efficient, long-life alternatives to incandescents. Recently, several styles have been marketed that can be screwed into a regular light socket in place of an ordinary bulb. I tried one in a bedside lamp, but find that I rarely use it. The light (despite advertising claims) is unpleasantly harsh, and up close has an annoying flicker. It also buzzes audibly. It isn't shaped exactly like an ordinary light bulb, either. The shade sits up higher than the lamp designer intended, exposing the unsightly white plastic base of the bulb, and making the entire lamp look odd. Thanks, but I'd rather have a regular light bulb.

Quartz-halogens have a very nice quality of light, and I prefer them to ordinary light bulbs but for two drawbacks. First, most of them operate on 12 V rather than the customary 120 V, and require a lamp with a step-down transformer and a unique socket. Therefore, they are not directly interchangeable with ordinary light bulbs.

Second, the bulbs are expensive, and when you add the cost of the unique light fixture, they are also expensive to install. Even if their long-term cost is lower, the up-front cost can be formidable.

Quartz bulbs that CAN directly replace an ordinary bulb have only recently appeared on the market, but these are even more expensive—about \$25.00 for one 30-W bulb. The 30-W bulb is claimed to supply as much light (and better quality light) as an ordinary 60-W light bulb. I may try one of these if and when the price comes down a bit.

I currently use a (12 V) quartz reading light, and like it. Even if it gets hot at times, however.\* What we really need is a lamp that produces good quality light and burns cool—the efficiency of a fluorescent with the light quality (and silence) of a quartz-halogen. But no one has invented this yet.

Do any fundamental laws of physics preclude the efficient conversion of electricity into light without the generation of copious amounts of unwanted heat? Perhaps we need to find, develop, and perfect another technology that produces light from electricity. I wonder how much research has been done on using electro-chemistry for lighting? The cyalume, more popularly known as the lightstick, produces absolutely cool light when two chemicals are mixed inside a plastic tube. The mixing liberates stored chemical energy in the form of greenish or yellowish light. It lasts for only an hour or so, but could it be possible to have a sustained light-producing reaction within an electro-chemical device? Electrical power would separate the reactants within an electrolytic cell. These would then flow into a transparent reaction chamber where they would recombine and produce cool light. Of course the color and brightness would have to be improved over what is currently produced by a cyalume, but who knows what is possible? Edison had to try hundreds of filament materials before



# PEASE PORRIDGE

he found a suitable one.

It might turn out that the electrochemical conversion steps cannot be made extremely efficient, and would produce waste heat. Even so, this could be done in a central reactor outside the air-conditioned environment, and the "charged" reactants piped throughout the home, office, or factory to where lighting was required. At the point where light was produced, it would be done without heat production. This would be ergonomically preferable, and still save the expense of pumping the waste heat out of the air-conditioned space. New homes would have central heat and air, and a central lighting generator.

If this idea bears no fruit, how about solid-state devices? The efficiency of LEDs is being increased continually, and recently etched silicon has been made to produce light from electricity, albeit with low efficiency. Perhaps further innovation will lead to a highly efficient semiconductor light source, though I have some reservations about monochromatic lighting. (The worst lights of all, to me, are the sodium-vapor and mercury-vapor lamps used in parking lots and other public places.)

How about producing all of the light in a single highly efficient source, and piping it to wherever it was needed with fiber optics? (A "light" socket would really be a light socket!) Too lossy, I suppose.

If all else fails, we can always begin raising fireflies in enormous numbers. If we can train them to respond to voice command ("light on"), we will have produced the equivalent of a cool-burning light fixture with a built-in "clapper."

\*The dichroic filter mentioned in your article sounds like just the ticket here.

**D. LEE HORNYAK**  
NASA

*John F. Kennedy Space Center, FL*  
When new ways to generate light efficiently are found, we'll hear about them. There's no conspiracy of silence there. Note, not all fluorescents hum—electronic ballasts don't. You could shop around more—vote with your dollars! I recently read about a "concept car" with a single central light

source, and light pipes—it looked disastrously stupid! How can it be efficient when you turn off the headlights and run only your brake lights?  
—RAP

**Dear Bob:**

Computers can be seductive—they can encourage you to do something unnecessary and time-consuming. Is it because the results look so nice that your audience may just ignore problems with the content? Is it because performing some tasks on a computer is a little like taking a mental vacation? Spending two hours drawing a simple schematic is easier on the brain than actually designing a circuit.

But I really don't want to trash computers—even the ones that make a satisfying crunch after a 30-ft. fall to the pavement. They do lots of things really well. We computer users simply have to learn when and how it's appropriate to use them.

For example, I've had some very good results from using spreadsheets. In the past, they've helped me do a few things faster and with less effort than I could have done with other approaches. If you think about what you want to do before you get started, a spreadsheet can give you a useful presentation of the results of many calculations. If you do something dumb, like using an erroneous equation, you can get wrong answers and not even know it because the equation giving you those wrong answers doesn't appear in the printout. The ideal way to print out your spreadsheet is to show the equations in the boxes right next to the results. That way, you're a lot more likely to catch mistakes than when all you print are the answers.

Do I hate computers? No, I think they're great. But occasionally I have to remind myself that they're tools. And like all tools, they do a good job when you use them appropriately and for a job you understand. You wouldn't try to pound nails all day with a screwdriver, would you? And even if you have a hammer, you might decide to find someone else to help if you can only hit the nail one time out of ten. If we use the same kind of guidelines before we decide to use computers, we'll be more productive.

Remember, "computers don't kill time, people kill time—with a little help from their computers."

**KERRY LACANETTE**  
Applications Engineer  
National Semiconductor

*Kerry, I sure agree, having the EQUATIONS printed out would help. Somebody says Mathcad is good for that.—RAP*

**Dear Bob:**

...I've got a comment or two to pass along. First, one of my pet peeves that I hear of from time to time is the so-called phenomenon of Engineering half-life or engineering obsolescence. I maintain that if an engineer has been properly educated, he is equipped to solve problems using skills that as yet don't succumb to any real deterioration—mathematics, for example.

If an engineer ONLY accumulated the surface skills and knowledge, such as Univac 1108 programming, without acquiring any underlying problem-solving/knowledge-accumulating skills, both the school and the individual are not properly doing the job of education. I believe this half-life balderdash comes from the accountants and managers who wish to keep a newer (i.e. lower-cost) staff around. They will try to convince anyone who will sign up for it that they will self-destruct in five or eight or ten years if they want to stay in the engineering domain.

It's also a fact of the engineering life that we as designers must keep learning what implementation options exist and how to apply them. Otherwise, our solutions will not fit the real world of the moment, even though they might work. If the old engineer won't progress from his slide rule to a calculator, he may still solve problems he faces, but at what loss of speed and accuracy?

**DEAN S. CARPENTER**  
Assoc. Staff Engineer  
Scientific Atlanta  
Norcross, Georgia

*If an engineer could focus on only one task, and could not keep his eye on other techniques, he might indeed have a "half-life." That's where Electronic Design is very valuable. I agree, education is a lot better than training.—RAP*

# WHAT'S ALL THIS FUZZY LOGIC STUFF, ANYHOW?

**A**s you may have noted, several people have asked me what I thought about "Fuzzy Logic" (abbreviated to F.L.). When I was finally able to stop laughing, I agreed that if its name wasn't so weird, it would be easier to take it seriously (*Bob's Mailbox*, July 9, 1992, p. 80F). Then several people wrote in (*Bob's Mailbox*, Oct. 1, 1992, p. 74) to explain that F.L. was just a set of simplified analog/digital conventions that weren't really so new after all.

All this time I kept inquiring, what does Fuzzy Logic do that you can't do in conventional or traditional ways. I kept hearing, "Oh, you can do wonderful things." And, "You can get better results than with conventional logic."



**BOB PEASE**  
OBTAINED A BSEE FROM MIT IN 1961 AND IS STAFF SCIENTIST AT NATIONAL SEMICONDUCTOR CORP., SANTA CLARA, CALIF.

their seats. Whereas, he claimed, by using Fuzzy Logic, you can accelerate smoothly, hold a constant top speed, and decelerate smoothly to the station.

Well, anybody who has ever ridden a subway or streetcar knows that they

never accelerate and jerk viciously like that. Even the guy who wrote the article must have known that. So why did he set up such an absurd straw man??? Why does he insist that F.L. is superior to a jerky system that has never existed? Even in the 1890s, electric trains and trolleys were operated smoothly with the "new" Westinghouse controllers. I know—I have ridden 90-year-old trolleys, and they operate almost as smoothly as modern ones (such as BART).

Now, I have never studied all the detailed languages of Fuzzy Logic, and I probably never will. But I have studied motion controllers of various types, both analog and digital. There are lots of modes of operation. If you want to provide good smoothness (to minimize the "jerk" =  $da/dt = d^3x/dt^3$ ), there are many ways to do that. And if you just want to get there fast, there are ways to do that, too.

Of course, if you used the crudest possible bang-bang controller, you might get some of the disadvantages cited by the fans of F.L. But that's unfair. When you use some sensor (analog or digital) to detect where you are, you may use inexpensive data converters to get the information into either the analog or digital domain to tell the computer where you are, with adequate resolution. Then the controller can decide where you want to be, and how to converge smoothly on the correct answer without undesirable overshoot or jerk. It's not hard to make a controller do that, whether you rely on analog servos or digital servos. Further, even F.L. controllers may require sensors for position, velocity, etc. They cannot work optimally in a vacuum of information on the parameter to be controlled without any sensors—not any more than a conventional controller can.

But I kept reading strange claims in the literature. One engineer stated

that he could use Fuzzy Logic to control a switch-mode voltage regulator, which was better than a conventional, committed controller IC could do. But I never saw any *results*, just wild claims. Then another person claimed that Fuzzy Logic would be ideal for making a better elevator controller, because without Fuzzy Logic, the elevator would surely lurch and come to a rough halt, knocking everybody off their feet.<sup>1</sup> Now, REALLY!

Another author stated that a controller for pressure in a steam boiler had greatly improved response when a Fuzzy Controller was added—including a rise-time that was at least twice as fast.<sup>2</sup> Don't look now, but you get 2× faster rise-time by applying twice as much power. If Fuzzy Logic seems to be achieving that advantage for you, that's only because the conventional system must have been terribly designed.

And various readers kept sending me copies of articles, ads, claims, even several examples of poetry—all KINDS of obscure observations on how WONDERFUL it must be to use Fuzzy Logic. I bounced some of these claims off my old friend Tom Harper in the Embedded Controller group at NSC. Tom observed that if you really know what you want to do, Fuzzy Logic does not always offer much of a performance advantage (if any) over a conventional or "deterministic" controller. In other words, maybe a F.L. power controller can do better than an old LM3524, but so can lots of other more modern controllers.

So it's not obvious where the actual advantage is if the "improvement" is just claimed to be the inherent advantage of the Fuzzy Logic. However, Tom pointed out, in some cases where nobody knows how to control the system, the F.L. controller may be able to control things better.<sup>3</sup> Then by watching the Fuzzy controller, you may learn how to control the system even better than the Fuzzy controller.

But the claims kept coming in. "Fuzzy controllers have inherent advantages." And, "The Japanese are putting Fuzzy controllers in refrigerators and washing machines and cameras." Well, if the Japanese are doing

# PEASE PORRIDGE

it, it must be superior, right??

Another example I heard on the radio: An "expert" stated that some new cars have an automatic transmission that uses Fuzzy Logic. They are much superior to transmissions without F.L., because transmissions without F.L. always shift at the same speed, whereas transmissions with F.L. can shift at different speeds.<sup>4</sup> Hey, get a life! Don't try to tell me about the right way to design automatic transmissions when you've apparently never even driven a car!

One day I was talking with Frank Goodenough, and I was griping that all I ever heard about F.L. was a whole lot of PLATITUDES and straw-man arguments, and about the OBVIOUS INHERENT SUPERIORITY of Fuzzy Logic. Then I just *cracked*—I got ticked off and pointed out to Frank that so far, everybody says that F.L. is so great, but we never see any *real* advantages, not any *real* examples. OKAY, here's a solution to this vexing situation. I will send out this CHALLENGE to any reader:

Show me a system—your system or somebody else's system—where Fuzzy Logic is claimed to provide performance advantages over conventional controllers or systems. You can show me any kind of system, whether it's electronic, electrical, electromechanical, a switch-mode-regulator, or whatever.

But, it cannot be just a conceptual system, or a block diagram, or just a computer simulation. For a fair comparison, it has to be something that really works—that really does *something*. Furthermore, you must show me the corresponding conventional controller, and the advantages of the Fuzzy system in terms of *actual performance*. You must also show the actual interface, including the sensor that provides the inputs to the controller, and the actuator that converts the controller's commands into the real world. Then I can build one if I want to.

HOWEVER, I reserve the right to point out that perhaps the CONVENTIONAL system was a real clunker, so it was no wonder the F.L. controller could do better than that. In fact, I may be able to show that any thoughtfully

designed system could do better than the Fuzzy Controller. If you just set up a straw man and knock him down easily, you can be sure I will stand up that straw man and put some steel in his backbone, and we'll try again.

So, if there really is a place where Fuzzy Logic is better than ordinary controllers, you show me, and I'll check it out, and I'll concede that there are some interesting advantages. But if you make unrealistic comparisons, I may just show that you were sandbagging.... Therefore, you'd better show me the improvements in a realistic system. And it must be in a format where I can really evaluate the results. Either build up a circuit and send me both versions, or show me how to build it.

As you can see, I am kinda tired of hearing all these platitudes and vacuous claims and unbelievable advantages and other BULLBLEEP. And theoretical stuff that ain't gonna hold no water. If Fuzzy Logic is better at *everything* (which some people claim, but which I doubt), we'll find out. If it really is better at a small class of special cases, that we will find out, too.

For example, if we both set up a controller to run a train, and it really runs very well in tests with the train empty, does it still stop safely when the train suddenly fills up with passengers? You might like to argue that your Fuzzy controller can make a train start and stop faster and more optimally when full, empty, or under any other load conditions. Then I'll surely reply that making a train stop at 0.7 Gs is not really practical if the improved performance knocks all of the passengers off their feet and makes them ill. So you had better have a rational improvement, with REAL numbers for REAL examples, because I won't be fooled by platitudes and baloney and bluster and bullbleep. And if in fact you're just trying to fool yourself and me, we'll just publish it...and we'll have a good laugh.

Since Frank Goodenough and I will be the judges, I think we will see some interesting situations: "I can sing anything higher than you can." "No, you can't." "Yes I can...." We shall see. Meanwhile, readers' comments on, where F.L. really *does* and *does not* provide advantages, are invited. But

no bullbleep, and no platitudes. And Frank and I reserve the right to use anything we want to, vacuum tubes or digital multipliers or analog multipliers, to show that conventional controllers are adequate, or just as good, or better, or whatever. And after Frank and I do our judging, and write up our results, YOU can study what we say, and YOU can make your own judgments.

Note, some thoughtful people are beginning to admit that F.L. controllers don't necessarily offer much better *performance* than a conventional digital controller. A Fuzzy controller may even be able to bring a boat to its dock just about as quickly and smoothly (and, just as jerkily) as other controllers. But the Fuzzy controllers are *adequate*, and they're claimed to have an advantage of being relatively easy to program.

Now I'll agree, that's a perfectly plausible set of advantages. But it's a little different from a writer who claims that conventional digital controllers are inherently terrible "...because a digital computer can only recognize a one or a zero."<sup>5</sup> Haven't these clowns noticed that computers don't operate on just one bit—they operate on *bytes*? Because a byte with 8 (or more) bits can represent a signal with a resolution of 1 part in 256 (or more), a well-designed digital controller can obviously operate as smoothly as you would like. I have yet to see proof that that statement applies to Fuzzy Logic controllers.

Furthermore, some knowledgeable engineers do NOT agree that F.L. is any easier to program or optimize... they observe that Fuzzy Rules can be hard to write well. Emdad Khan in NSC's Intelligent Systems group cautioned that "for complex systems, developing Fuzzy Rules is very difficult, especially if the system needs more than 20 rules and has more than 3 inputs and/or outputs. At this point, the designer starts losing the capability to relate the rules together; in other words we lose the main capability of Fuzzy Logic."

NOW, it's true that some controllers do exhibit a sawtooth curve like the subway train example I mentioned earlier. The thermostat in my house

## PEASE PORRIDGE

gives that exact same response when I turn it on in the morning. But that's OK, perfectly adequate, so long as the peak-to-peak temperature band is only a few degrees. I'm certainly not going to go out and buy a proportional furnace and control system for the heat in my house!

Several friends have commented: "Bob—this column sounds like you are in favor of digital control systems? How *surreal!!!*..." Now, don't get me wrong. I'm not saying any one kind of controller is good or bad. I am just arguing that you should *think* about what your computer or controller is doing for you, and try to understand it. If somebody says his new Fuzzy controller can solve all your problems with greatly improved performance and no thinking is required... think again. Think it over. Ask to see examples of things that really work. Do they show real advantages, or just conceptual advantages compared to a straw man? Do a sanity check—a reality check.

All for now. / Comments invited!  
RAP / Robert A. Pease / Engineer

Address:  
Mail Stop C2500A  
National Semiconductor  
P.O. Box 58090  
Santa Clara, CA 95052-8090

1. Electronic Design, June 25, 1992, p. 37, "An elevator not based on Fuzzy Logic runs at constant speed until it reaches the destination, then comes to a rough halt". (NO, I am NOT making this up.)
2. *Fuzzy Logic*, Daniel McNeill and Paul Freiberger, p. 115, Simon & Schuster, 1993; about \$22, not worth the price unless you really like *platitudes*.
3. NeuFuz 4 control system; announced by National Semiconductor, April 1993. It's not just Fuzzy Logic, but a whole lot more. For information, call 1-(800) 272-9959.
4. Daniel McNeill interviewed on "Marketplace Radio," KQED-FM, March 23, 1993 (6:49 P.M.).
5. *Fuzzy Logic*, McNeill & Freiberger, as quoted in the *San Francisco Chronicle* Book Review.

"I'm a vice president because I sold 22,000 gizmos this year. How'd you become a v.p.?"

"I made a great deal on the 200,000 gizmos you didn't sell last year."



Turn your excess inventory into a  
tax break and help send needy  
kids to college.

Call for your free guide to learn how  
donating your slow moving inventory can  
mean a generous tax write off for your company.

Call (708) 690-0010

**EAL**

Post Office Box 3021  
Glen Ellyn, IL 60138  
Fax (708) 690-0565

*Excess inventory today...student opportunity tomorrow*





# BOB'S MAILBOX

**Dear Bob:**

I've been seduced by your March 4, 1993 column in which you discussed the problem of battery charging for camcorders. I, too, have spent a little time in the woods, some of it in the Sierras down the road apiece from you. Each time I've come out of those woods, I've had to perform a rather lugubrious task at the Redwood City HoJo the night before my plane left for home. The airlines don't like you to have loaded butane cook-stove canisters in your backpack, so I always burn off the remaining fuel the night before out near the pool or on a balcony. Every time I do this, I'm amazed at how long the damn thing burns; there's a lot of energy in one of those lightweight cans. Lots of BTUs, but not easy to convert.

I've been trying to get some time to do the calculations to see how much energy could be extracted from a small steam turbine driven by one of these very large cigarette lighters. Seven watts should be easy. Well, you know how that goes.

Anyway, I thought I'd suggest the solution to you, because you're obviously more obsessed than I am, and probably have more incentive to boot. The only penalty with this solution is using up some water, and often that's not a problem. It might even be possible to steam vegetables or something while you charge your battery. Perfect for Ronco, really.

Let me know if you follow up on this. Not only am I dying to know if it works, but I'm sure we could corner the market together.

I always enjoy your column in Electronic Design. It's one of the few places to share the Joy of Engineering in what has become a vast digital swamp.

**ED GREYDA**  
**President**  
**Castle Island Co.**  
**Arlington, Mass.**

*Next time, give your propane to another hiker! But I don't know where to find a light boiler and steam engine*

*(turbine not piston). Read on.—RAP*

**Dear Bob:**

This is just a brief technical comment on your March 4, Column "What's All This Battery-Powered Stuff, Anyhow?"

I am a French analog IC designer, dealing especially with analog ASICs in the field of military and space applications.

My suggestion is to use a Peltier-Seebeck module to directly convert heat to electricity. It is probable during your trek to have some heat from a burner or fire to convert into a charge current for your batteries.

The tiny Peltier-Seebeck module could be pressed between a copper bar and a heat sink. A careful study, with a proper module selection and a good mechanical/thermal design, could result in a compact power source. Very significant amounts of power can be generated this way. Let's remember that such generators are sometimes used in outer space (some were used to power the data-acquisition/transmission systems Apollo missions brought to the moon, and for flying spacecrafts like Voyager I and II).

That solution may not be very cheap (modules are priced at several tens of U.S. dollars) but could be reasonably lightweight.

Thank you for your column. I enjoy your particular mix of technique and philosophy.

**JEAN-FRANCOIS DEBROUX**  
**France**

*I have seen some thermoelectric modules, but I recall them being rather heavy, inefficient, and expensive. I have requested literature—and will study.—RAP*

**Dear Bob:**

Regarding "...Battery-Powered Stuff," your cranky generator is probably the most practical solution. However, you might want to consider a few off-the-wall concepts:

Consider the heel impact energy of

a person walking on soft soil with 0.5 in. of "give." For a 100-lb. person at a brisk walk of 100 foot-falls per minute, this figures to 0.04 ft. × 100 lb./0.7 sec. = 5.7 ft.-lb./sec., or almost 8W. Convert this at 20% efficiency with boot bellows pumping into an elastic reservoir, supplying a small air motor driving a lightweight high-speed generator, and you can tape for about 1 hour each day. *(Not likely!—RAP)*

Or consider a typical Sterno can under a pan of rice. Mooch about 1% of the energy flow with a thermoelectric module like they use in 12-V dc pop-can coolers, and charge your batteries while cooking dinner. *(Not likely; they're inefficient and you'd need a bonfire.—RAP)*

Or consider the heat of formation of aluminum oxide (Al<sub>2</sub>O<sub>3</sub>). If you need 120 watt-hours to fill your supply of tapes, you need about 100 KCalories at about 400 KCalories per mole. This means that you would need to carry only about 32 grams of aluminum to supply the whole trip at only 10% electrochemical efficiency. Have you ever come across an aluminum-air fuel cell? *(No, not likely.—RAP)*

Or revisit the alkaline "D" cells. If you limit discharge current to 100 mA and pull the voltage down to 0.7 V, each cell can supply almost 20 watt-hours. Play dc-dc converter games with a small sealed lead-acid battery to supply peak current at a total efficiency of 72% (85% for dc-dc and 85% for the lead-acid battery). You could supply your hypothetical 20-day trip using only 8.4 alkaline D's.

**BEN BARNETT**  
**Instrumentation Engineer**  
**YSI Research Center**  
**Yellow Springs, Ohio**

*Now that last paragraph is obscure, but quite feasible! Somewhat promising, and good Engineering! I'm working on a 98% efficiency switcher.—RAP*

**Dear Bob:**

I am tired of hearing in your

## PEASE PORRIDGE

columns, and elsewhere, "I'm one of those non-degreed engineers 'who gets no respect' monetarily or otherwise." Can one claim to be a medical doctor after learning how to use a stethoscope, or a dentist if one know how to use a drill, or a lawyer if one handled his/her own case in small claims court? How ridiculous a complaint!

Shall four to six years of sacrifice and formal engineering study (and up to \$80K in tuition) be cast aside so lightly to think that someone who has read hobby magazines and the Radio Amateur's Handbook can be a match for someone who has studied in an accredited engineering program to learn basic fundamentals? How absurd! Does this non-degreed engineer have basic knowledge of higher mathematics, electrical-engineering basic analytical fundamentals, civil-engineering principles (i.e. shear, strength of materials, etc.), mechanical-engineering principles (laminar flow, thermodynamics, mechanisms, etc.), or drafting practices (developments, detail drawings, descriptive geometry, etc.). The "non-degreed engineer's" answer is "I don't have to know that to do my job." That's correct. He has a job, not a profession!

How demeaning it is for the degreed engineer to see someone called a "company engineer" after all the hardship he went through to obtain his degree(s). I have seen "company engineers" perform their assigned tasks well. But ask them to perform a loop analysis or to find the rms value of a waveform, etc., and they look at you with a blank stare.

If all of the advanced study that a degreed engineer is required to go through really is not needed on the job, what a cruel hoax the engineering executives in this country have played on some of the most intelligent people in our society! Apparently, since engineering enrollment is down in our universities, prospective engineers are not only intelligent but have become "smart." Why go through the cost and rigors of an engineering education when others who just know how to slap some chips together can have the same prestige, respect, and salary as the degreed engineer?

In addition, what a hoax was played

by corporate management on the degreed engineer by claiming a shortage of engineers that never, ever existed just to obtain an abundance of cheap labor. The "company engineer" concept is another corporate idea for acquiring cheap labor.

What engineer hasn't pondered the thought that he might have been much wiser in his youth if he had sought a career in medicine or law and became a real professional with prestige, respect, and financial reward. Tell it like it is Bob, I dare you to put this in print!

### NAME WITHHELD

*The IEEE didn't help us much on the "engineering shortage," did they? As for the ability of engineers to handle math, theory, etc., I see a virtually infinite array of capabilities. I don't find all that much correlation between the degree and the abilities. Surely a lot of degreed engineers can't remember how to compute the rms value of a lumpy waveform!—RAP*

### Dear Bob:

Your articles are usually one of the most interesting features of Electronic Design, and I have so many comments about the last few that it is hard to decide where to start.

First the comments about computers and spreadsheets: I agree with you. It is amazing how upset some "engineers" get when you criticize computers. My philosophy is "If you really want to get something done, don't turn the computer on." Spreadsheets are useful, but they are a keypuncher's dream and can waste a lot of time. Since I am a consultant and get paid by the hour, my clients usually are not willing to pay for too much wasted time.

The same can be said for simulation programs. You can spend hours simulating an RF filter, doing tolerance analysis and changing values to optimize it. Then once it is built, you find out that it is not quite the same as the simulation because of leakages or other factors. The best approach is to first sit down with a pencil and paper and THINK about the problem and what the possible approaches are. Write a few equations, if you still remember how, and see how things look. Sometimes you can even differentiate them, set them to zero, and see if there

may be an optimum solution for the configuration. If you can't do that, sit down and review your old calculus book and some basic books from your freshman and sophomore years in college.

Some engineers even think that basic concepts no longer apply in this age of digital circuits and computers. I think the biggest problem with engineers today is that they don't think enough. Their first *problem* in approaching a problem is to start punching keys and see if they can eventually find a solution by trial and error.

On your article about Compensation, etc.: I have always believed that the best engineers are the curious ones, and it is in the company's best interest to encourage hobby-circuit construction. I was very surprised to find out that NSC sells National parts to employees. I don't know why other companies don't encourage engineers to build circuits at home, because it makes them better engineers at a very modest expense.

On the other hand, NSC has recently made it very difficult for outside users to use their parts. The company hasn't gone to any trade shows where I usually get free catalogs, it only sells them now. If I don't have up-to-date information on the devices, I can't design them into new products. Another problem is that even if something is in the catalog, there is no guarantee that it won't be obsolete in a month or year because a major customer stopped using it. (*We're working on that.—RAP*) We need a better system for knowing what parts should not be used in new designs. Another thing a manufacturer should realize is that engineers are most likely to use their parts if there are samples in the drawer.

It sounds like NSC is a great place to work.

### JON GROSJEAN

**Woodstock Engineering  
Woodstock, Conn.**

*I agree with you about thinking vs. computers. Note, NSC mostly donates parts to employees to design with. But if I want to build my own computer or electric car, they'll sell me the parts. NSC is indeed a challenging place, as we never run out of things that need to be done better.—RAP*

# WHAT'S ALL THIS TAGUCHI STUFF, ANYHOW? (PART II)

*Electronic Design extends an open invitation to Dr. Taguchi or any of his proponents wishing to respond in print to Bob's comments.*

Once upon a time, some engineers at Nippon Electric Corp. (NEC) had designed some voltage regulators for television sets to put out +115 V dc at 600 mA.<sup>1</sup> But because the regulators were built of inexpensive  $\pm 5\%$  components, a few of the circuits sometimes had an output variance as bad as +25 or -25 V, so they could not be trimmed to 115 V using the adjustment pot. Then Genichi Taguchi proposed to help them by using the new "Taguchi method" to optimize their circuit and improve the yield ("What's All This Taguchi Stuff, Anyhow?," June 25, 1992, p. 83). He used NEC's basic circuit shown in Figure 1, and the equations and the initial values of components in Figure 2.



**BOB PEASE**  
OBTAINED A BSEE FROM MIT IN 1961 AND IS STAFF SCIENTIST AT NATIONAL SEMICONDUCTOR CORP., SANTA CLARA, CALIF.

He also used his proprietary "Taguchi method," with orthogonal arrays,<sup>2</sup> to help "optimize" the circuit and get the output voltage to have less variation without using expensive, tight-tolerance components. And he succeeded.

My, he really made a big improvement. Instead of an output variance of  $\pm 25$  V, Taguchi achieved a variance of  $\pm 1.5$  V. If some of the resistors had a

bad tolerance, that didn't cause the output to err excessively. Very good. And even if the Reference Voltage had a tolerance of 5 or 10%, the circuit was still more accurate than 2%. Great! But—hey—wait a minute! Does that make any sense? Ah, let's set this question aside until later.

In his 1979 book, *Introduction to Off-Line Quality Control*, Dr. Taguchi observed that this 115-V regulator was an excellent example of how to use his techniques to get low variability.<sup>3</sup> After all, Taguchi said, "I define quality as the losses a product imparts to society from the time the product is shipped."<sup>4</sup> If your products don't have quality, you're robbing from widows and orphans. And if you can use low-cost components to achieve high quality, then you have used the Taguchi method wisely. That's much better

than the common engineering practice in the United States of "throwing money at the problem."<sup>5</sup>

Furthermore, observes Taguchi, the wise way to engineer a circuit such as a voltage regulator is to trim one resistor to achieve a substantially flat slope by working on a parabolic curve in the region where it gets flat.<sup>6</sup> If your circuit has a positive sensitivity with a steep positive slope, you may find that a mere 100- $\Omega$  resistance shift of one certain 200- $\Omega$  resistor can make a terrible 22-V change in the output. Once again you are imparting losses to society. But if you set this resistor at 350  $\Omega$ , minor variations in resistor value have virtually no effect (see Figure 3).

Ah—now—which resistor is that? And in what circuit is that? Can Dr. Taguchi please explain? (Dr. Taguchi has been demurring.) But, he says, after you use the resistor to trim the output to where the slope is zero, you can then specify a higher or lower beta on one of the transistors to force the  $V_{out}$  back to 115 V. (Which transistor? Dr. Taguchi has no comment.)

One of the instructors who teaches, among other things, the Taguchi method, Professor Thomas Barker, from the Center for Statistics and Quality Control at the Rochester Institute of Technology, expanded still further in his book.<sup>7</sup> He says we should take advantage of this type of circuit that has low sensitivity to variations in one part of its curve. We should select

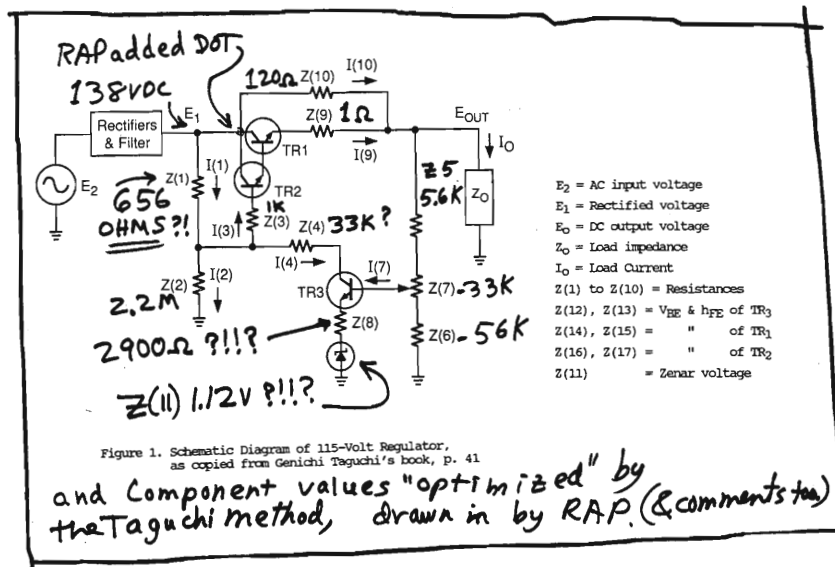

# PEASE PORRIDGE

a transistor with higher  $h_{FE}$  (higher than 10 or 20, as high as 40, but not any higher or the sensitivity will get worse again), until the slope or gradient of ( $\Delta V_{out}$ ) vs. ( $\Delta h_{FE}$ ) is flat. Then trim a resistor to get the output back to 115 V dc. Which transistor should one select? Which resistor should one then trim? In what circuit? I have asked Professor Barker several times, but he has never supplied an answer.

Now, isn't that funny? Dr. Taguchi proposes that we should select the resistor to get a flat slope of  $V_{out}$  vs. resistance, and then tweak the transistor's beta to hit the target for  $V_{out}$ . Professor Barker claims to be teaching the Taguchi method, yet in his book he teaches to select a transistor for medium gain to get a flat slope of  $V_{out}$  vs. gain, and then trim a resistor to get the desired  $V_{out}$ . Which one is right??

Can they both be right?? Let's go back and look at that circuit....

The original NEC circuit had an 11.2-V Zener at z(11), and  $z(5)/z(6) = 10$ . The noise gain of 11 caused the output to be around 115 V, although with the usual variations due to the component tolerances. The original component values are shown in the chart in Figure 2. But the "optimal" values of the components are also shown in Figure 1—the ones provided by the Taguchi method's "optimization." As you can see, I have pencilled in the "optimal" resistor values right beside the resistors so we can see what's happening, whereas Dr. Taguchi put them on another page where it's hard to see what's going on.

NOW I can see what is going on. If  $V_{in}$  is 138 V, and  $V_{out}$  is 115 V, then  $z(1) = 656 \Omega$ , which means it has to have about 20 V across it, and about 30 mA

going through it. Okay, but where does that current go? The base of TR1 doesn't draw even 1 mA. So, can the current go through z(4)?? Hardly. The value of 33 k won't permit 30 mA to go through it. THEREFORE, this circuit as presented cannot work; the output voltage would be 133 V. There must be an error somewhere.

Let's take a quick look at the equations for  $V_{out}$ . The value of z(4) wasn't included in any equation. So, perhaps it was a minor error to assume that setting an arbitrary value of 33 k for z(4) would not cause any harm. Let's propose that z(4) now has a lower value, 10  $\Omega$  or 100  $\Omega$ , to give the circuit a chance to regulate. That's still consistent with the equations and their intent.

If 30 mA flows through z(1), TR3 can now sink this current. If  $V_{out}$  is about 115 V, TR3 will be at about the right level to draw that 30 mA through z(8) and through the reference diode z(11), a 1.12-V Zener.

Hey—what's the story? Can a 1.12-V Zener work in this circuit? Are you sure that's not a misprint?? Well, there's a Zener reference, z(11). But remember—Dr. Taguchi stated that he wanted the output voltage to be 115 V, "robust" and invariant of tolerances of the reference voltage. He wanted  $V_{out}$  to be 115 V invariant of the resistor values or tolerances. In fact, he said he wished the output to be 115 V invariant of the values of the voltage divider, and even invariant of the setting of the adjustment pot (refer to z(5), z(6), and z(7)) that "trims"  $V_{out}$ . And that's the result he got in the optimization provided by his method.

Okay—what is going on here? The output voltage of 115 V is alleged to have a tight tolerance and is invariant of any of the component values? HOW CAN THAT BE?? The answer is easy: Dr. Taguchi asked the computer to optimize this circuit with a nominal input voltage of 138 V, and the computer gave him a circuit whose output depends ONLY on the input voltage—the  $V_{out}$  is just 83% of  $V_{in}$ . If the input voltage moves 10 V, the output will also move 8 V, but no resistor or Zener values have any significant effect on  $V_{out}$ . (There is a fine-print disclaimer saying that the output voltage, with a fixed input of 138 V dc, is the only pa-

Output voltage denoted by y is given by the following equation:

$$A = Z(2)/(Z(1)+Z(2))$$

$$B = 1/Z(15*Z(17))((Z(1)*Z(2)/(Z(1)+Z(2))+Z(3))+Z(9))$$

$$D = (Z(1)*Z(2))/(Z(1)+Z(2)*Z(13))$$

$$E = Z(6)+0.5*Z(7)$$

$$C = Z(5)+0.5*Z(7)$$

$$F = (C+E)*(1+Z(13))*Z(8)+(C*E)$$

$$G = Z(11)+0.6$$

$$P = 1/Z(10)+1/(110/0.6)+13.67/Z(10)*(110/0.6)$$

$$K_1 = (A+B/Z(10))*(1.38*100-1.33)+D*(C+E)*(G/F)-1.2$$

$$K_2 = 1+D*(E/F)+B*P+A*13.67/(100/0.6)$$

$$Y = K_1/K_2$$

Factor Symbol	Initial Mid-value	Optimum Mid-value
Z(1) = A	16400	(656)
Z(2) = B	220000	(220000)
Z(3) = C	1000	(1000)
Z(4) = D	33000	(33000)
Z(5) = E	56000	(56000)
Z(6) = F	5600	(56000)
Z(7) = G	3300	(33000)
Z(8) = H	58	(2900)
Z(9) = I	1	(1)
Z(10) = J	120	(120)
Z(11) = K	11.2	(1.12)
Z(12) = 0.6 (fixed)	-	-
Z(13) = L	130	(1300)
Z(14) = 0.6 (fixed)	-	-
Z(15) = 100 (fixed)	-	-
Z(16) = 0.6 (fixed)	-	-
Z(17) = M	130	(130)

Figure 2. Formulae & Equations for computing the output voltage. Copied faithfully from Dr. Taguchi's book, p.42. Beware of many errors. RRP



# PEASE PORRIDGE

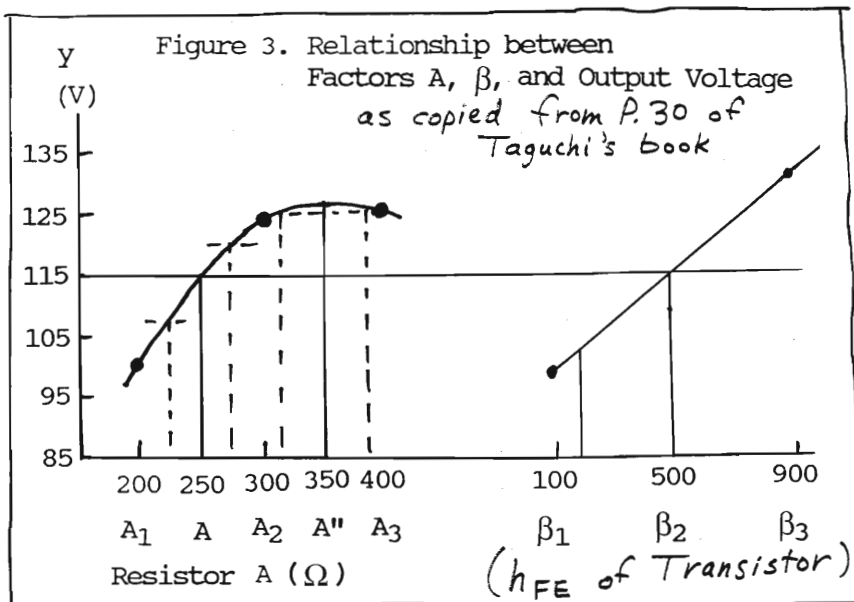

parameter being optimized; all other characteristics, such as line regulation, aren't considered).<sup>8</sup> I built this circuit, and after I changed  $z(4)$  to a low value, the output went right to 116 V—so long as the input was at 138 V.

Dr. Taguchi and his friends have established "robustification" as a highly desirable procedure whereby a desired output is "robust," largely immune to parameter changes.<sup>9</sup> In this case, Taguchi wished to have the output invariant to any resistor changes—but he neglected to say that he still wanted it to REGULATE! He forgot to check to see if the "optimal" circuit would still keep a constant output vs. changes in  $V_{in}$ . So he got what he asked for. And he did not check the answer. Needless to say, this kind of "optimization" is great for filling in a chapter of a book, but not so good for making TV sets that work.

Taguchi claims in his book that there are some resistors that have a steep effect on  $V_{out}$ , but the best circuit that achieves the much-desired "robustness" has excellent invariance to resistor values.<sup>10</sup> Well, there's no place in the NEC circuit for a mere 250- or 350- $\Omega$  resistor to have the effect that Taguchi claims. I wonder WHAT the Taguchi circuit could REALLY BE? EXACTLY where did he connect his 350- $\Omega$  resistor? I have made pointed inquiries, but have yet to get any answer.

Professor Barker also takes note of Taguchi's "optimal" regulator and its

fantastic robustness. He claims that in the best version of the regulator, improving the beta from 20 to 40 will increase the output voltage and then cause a decrease of the sensitivity to beta. But, increasing the beta past 40 will cause a further degradation of sensitivity. I wonder what circuit he's been using? I've been asking for years, since January 1990, and still haven't gotten an answer. Maybe it's just a "hypothetical" or imaginary circuit? With merely some "conceptual" robustness against all resistor variations?

I mean, if an engineer wants to propose a hypothetical circuit, that is OK; I do that all the time. But I cannot then use the hypothetical circuit to prove that I'm a better, smarter circuit designer with superior design techniques. If I can make my hypothetical circuit jump through conceptual hoops, nobody else can criticize me because there actually is no real circuit like this....

Look, gentlemen, you can't have a circuit that has perfect accuracy despite all sorts of tolerances, which you achieved by adding in wishful components that reject all of the conceptual imagined variations. It's time now to admit that there never was a regulator circuit that had all of these advantages. It's time to admit that Dr. Taguchi exercised his computer to "optimize" a circuit until it did not regulate at all. A 10-V change of  $V_{in}$  would cause 8 V of shift on the output. A ripple of 20 V on

the main filter gives a totally unacceptable ripple of 16 V on the output—IF you build it.

These Taguchi experts hope you will follow their tortuous reasoning, which is if you can make a circuit more "robust" against one thing, then that should likewise make the circuit more "robust" and insensitive to other parameters. A perfect, truly "robust" design will make the output invariant of "everything."<sup>11</sup>

LOOK HERE GUYS, the output voltage has to depend on SOMETHING. If it doesn't depend on one thing, it has to depend on something else! You can't live on wishful thinking forever.

Meanwhile, the righteous Taguchi experts heap insults on honest engineers: American engineers try to solve a problem by "throwing money at it."<sup>12</sup> They "gold-plate" the invention with "the most costly components."<sup>13</sup> Well, I think that cutting down the Error Budget by spending a few pennies to buy a couple of 2% resistors for  $z(5)$  and  $z(6)$  is a lot better than heaping on bovine manure to confuse the situation, with complicated matrices and huge equations. Everybody knows that a 10% tolerance of a regulator's reference voltage will cause a 9 or 10% shift of  $V_{out}$ , and anybody who tries to pretend it won't cause a shift has probably designed an un-regulator.

Still, Taguchi insists that a regulator that ages and goes out of tolerance can cause the whole TV set to be thrown away.<sup>14</sup> Don't look now, Dr. Taguchi, but the whole reason for putting in an adjustment pot at  $z(7)$  is so you can tweak the  $V_{out}$  and get the set back into spec without a big "loss to society." Taguchi is the one who doesn't understand the situation.<sup>15</sup>

Please note—Dr. Taguchi and Prof. Barker did not just observe that the regulator circuit was the beneficiary of some very good "optimization." They embellished the situation by claiming they knew the secret of how to achieve such good results, which is by selecting the value of one component so that the circuit was less sensitive to variation in that component. Unfortunately, they never checked to find out why the "variation" was so "good"—why changes in the reference voltage

## PEASE PORRIDGE

did not cause changes in the output voltage. They never checked to see that the circuit was NOT WORKING. They never built the circuit.

Furthermore, by using fancy matrices and orthogonal arrays and computer programs, they obscured the actual procedure of optimization. They trusted the computers to give them a perfect answer, so they didn't have to think about the process or understand the answer. Their computer took away their reasoning, and the optimization process gave them no insights. I'd never put up with that. I'd never let my engineers do that.

Now, anybody can make a mistake. But after you ask your computer to do something for you, you check it. If the computer designed an optimum that's absurd, you stop and go back and redesign. But, apparently, Dr. Taguchi was so confident that a 16X improvement in tolerance was the natural result of his "Taguchi method," he never checked his results.

Too many people who trust their computers seem to be neglecting to do a sanity check these days.... So much for the "widge amplifier," or more correctly, the "widge regulator" that took me several *years* to figure out why it seemed to be too good to be true.

(Note: Don't try to use Taguchi's equations from Figure 2 to compute what that circuit is really doing, because those equations have erroneous terms in them—heaven knows where they came from—and they give answers that can be off by 6 to 16%. I know, because I tried to derive these and I couldn't. So I derived the true equations, which are rather different from these. Available on request to anybody who's a nut about regulators....)

Next, I'd like to present some brief comments by an Expert who works for one of the Fortune 500 Companies (who prefers to remain anonymous). I talked to the Expert shortly after my original column came out.<sup>16</sup> He said that as a collaborator with Dr. Taguchi, he was obliged to point out that Taguchi himself doesn't say you must neglect and ignore "the parameters that are not under our control"; Taguchi can and does sometimes take those into account.

I observed that the video lecturer

who taught me, a Professor from a major Eastern technical school, was quite clear and adamant about this. So it seemed strange that that Professor claimed he was teaching us "the Taguchi method" if it was in contradiction to what Taguchi believes and teaches. The Expert also observed that Taguchi doesn't insist on using the absolute minimum of tests, but is willing to add tests to check for drifts and noises and other potential errors. Again, I wondered why the Professor called it "the Taguchi method" if his teachings were in diametric opposition to those of Taguchi himself.

The Expert observed that a number of people claim to teach "the Taguchi method," and some of them do teach things that Taguchi doesn't agree with. I replied that it's unfortunate that people seem to be putting words into Dr. Taguchi's mouth, yet he doesn't repudiate those other people's teachings, even when they have permission from Taguchi's American Supplier Institute to use the "the Taguchi method" trademark.

So it seems that some of the accusations I made in my earlier column, that I disliked the methods of Genichi Taguchi, were misplaced. I should state that other people who *claim* to be teaching "the Taguchi method" are apparently responsible for some of the ideas that horrified me. I'm sorry I accused Dr. Taguchi of teaching all those unacceptable ideas, which apparently belong to other people.

However, now that I have been able to pin down the facts, I find that Dr. Taguchi has showed some truly bad judgment in claiming glorious advantages for circuits that don't work at all. Also, some of his other optimization schemes show terrible errors. He uses his large orthogonal arrays in another book<sup>17</sup> to prove that the output voltage of a voltage regulator has just a small variation with  $z(4)$ . But  $z(4)$  isn't even represented in his equations. Maybe his computer got sloppy when evaluating that huge array of numbers?

He designed an "efficient" regulator to put out 600 mA at 220 V, with a 1000- $\Omega$  current-limit resistor that dissipates over 2000 W.<sup>18</sup> And it all runs on a 138-V dc supply without any switching mode. Really, with a

straight face, he presents this as an optimized design....

So while I must concede that some of my complaints against Dr. Taguchi were misdirected, I have found that every page I do understand, in every "Taguchi" book that I have seen, is full of mathematical errors, engineering blunders, and intellectual fiascoes. (Diamond's book, *Design of Experiments*, is one of the few exceptions—I find it quite good, per my recommendation in the June 25, 1992 column).

So I conclude that in this field, if anybody claims you must heed HIM because HE is teaching you "THE Taguchi method," hold onto your wallet tight and watch out for mathematical or philosophical errors. As with *any* teacher, you should be thoughtful and skeptical. If any "expert" proposes to teach you something, you should check it out with reality. Make sure it makes sense. Question authority, no matter who the teacher is. In this particular field, since there are several strong and contradictory claims, be aware that your skepticism may be justified.

One of my friends steered me to a recent story by Jim Smith and Mark Oliver—"Statistics: The Great Quality Gamble,"<sup>20</sup> which criticizes various aspects of statistical analysis, including a subsection on "Taguchi: Too good to be true?" It deals with people and insights in the workplace—experience and intuition, contrasted with overconfidence and over-reliance on statistical analysis. It includes the quote, "He who works with statistical methods alone won't be here in three years," said by Bill Deming, the dean of the Quality movement.

Another friend pointed out an article by Eugene Sprow, "What Hath Taguchi Wrought?"<sup>21</sup> It comments on Taguchi's methods from a rather different viewpoint, so if you're a statistician or a manufacturing engineer, you might like to read that to see where other experts think Taguchi's ideas are good, and where not so advantageous.

I hope you will agree with me that the outcome of all this debate will be beneficial: Every engineer should be aware that books or classes claiming to teach "the new Miracle Method" may indeed be telling you something too

# ATTENTION MARKETERS!

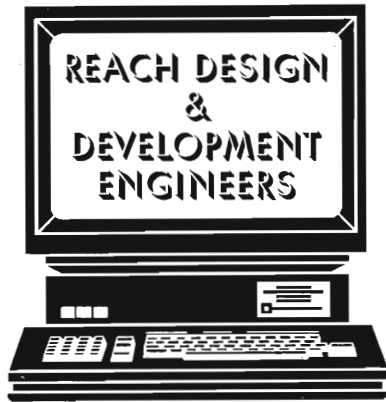

## ELECTRONIC DESIGN

subscribers are highly  
educated engineers and  
managers in the  
electronics original  
equipment market.

Select by job  
function, type of  
industry, purchasing  
influence,  
employment size,  
and geography.

●  
Guaranteed  
99% Deliverable  
100% BPA Audited.

Call your Advertising  
Representative, or call  
(216) 696-7000, and ask  
for the List Department.

Request your FREE  
Penton Lists Catalog!

# Penton Lists

## PEASE PORRIDGE

good to be true. Any book, any teaching, deserves to be considered skeptically.<sup>22</sup> Every engineer should think, every reader should THINK. Should they trust Pease, or Taguchi, or any other teacher? I hope they will study and trust those people who show they deserve to be trusted. And we all deserve to be greeted with skepticism when we start making erroneous or foolish statements. QUESTION AUTHORITY!

All for now. / Comments invited!  
RAP / Robert A. Pease / Engineer

Address:  
Mail Stop C2500A  
National Semiconductor  
P.O. Box 58090  
Santa Clara, CA 95052-8090

(The opinions expressed herein are those of the writer and do not necessarily reflect the views of National Semiconductor Corporation.)

P.S. I did receive a pleasant response from Dr. Taguchi concerning my questions about the "optimized regulator" (personal correspondence, Oct. 27, 1992). He did not have any comments on voltage regulators, or "optimal values" that caused circuits to not regulate, nor on sensitivities to changes in a 200- $\Omega$  resistor. He just stated, "We are not interested in any actual results because quality engineering deals with only optimization." Unfortunately, if the actual result is a circuit that doesn't work, I can't consider the optimization anything but useless.... or, worse than useless.  
—RAP

1. Genichi Taguchi and Yui Wu, *Introduction to Off-Line Quality Control*; Central Japan Quality Control Association, Nagaya, Japan, 1979; p. 41. (This is surely Nagoya, but the book says Nagaya.)
2. *Ibid.*, p. 42-47.
3. *Ibid.*, p. 9-14.
4. *Ibid.*, p. 1. NOTE, I did not misquote Dr. Taguchi. I'm not the one who made up "I define quality as the loss to society...."; Taguchi said this.
5. Thomas Barker, *Engineering*

*Quality by Design*; Marcel Dekker, NY & Basel, with ASQC Press, Milwaukee, 1990; p. 13.

6. Taguchi, p. 30-31.

7. Barker, p. 12-16.

8. Taguchi, p. 42. "Also, characteristics other than the output voltage are not discussed."

9. Barker, p. 136.

10. Taguchi, p. 31.

11. I'm sure I read this *somewhere...* such as:

11a. Phillip J. Ross, *Taguchi Techniques for Quality Engineering*; McGraw-Hill, 1988; p. 177. "Making a circuit robust against one noise makes it robust against other noises also." Or:

11b. Thomas Barker, "The Quality Paradox," course notes from Center for Quality and Applied Statistics, College of Engineering, RIT; p. 7. "This empirical observation leads to an informal 'axiom' that says that if I can robustify a function for one type of noise, I can robustify it for any other type of noise."

12. Barker, p. 13.

13. *Ibid.*, p. 104.

14. Taguchi, p. 9.

15. *Ibid.*, p. 10, "This is the reason why such an act is more immoral than the actions of a thief."

16. Robert A. Pease, "What's All This Taguchi Stuff, Anyhow?," *Electronic Design*, June 25, 1992; p. 83-84.

17. Genichi Taguchi, *System of Experimental Design*; Kraus International Publications, White Plains N.Y., with American Supplier Institute, Dearborn, Mich., 1988; p. 379-389.

18. *Ibid.*, p. 382.

19. Robert A. Pease, "What's All This Statistical Stuff, Anyhow?," *Electronic Design*, March 14, 1991; p. 97-98.

20. Jim Smith and Mark Oliver, "Statistics: The Great Quality Gamble," *Machine Design*, Oct. 8, 1992; pp. 77-81.

21. Eugene E. Sprow, "What Hath Taguchi Wrought?," *Journal of Manufacturing Engineering*, Vol. 108, No. 4, April 1992; pp. 57-60.

22. Robert A. Pease, "What's All This Critical Thinking Stuff, Anyhow?," *Electronic Design*, June 27, 1991; p. 119-120.

## PEASE PORRIDGE



# BOB'S MAILBOX

### Dear Bob:

I just read your April 1 column on "What's All This Doctor Science Stuff, Anyhow?" You don't know how much that humorous article brightened my day. (Of course you don't. It's metaphysically impossible). Several years ago, while doing a contract job in Norfolk, Virginia, I was listening to the local rock station and they did a series of "commercials" for the Heiney Winery (run by Big Red and his brother Thor).

Upon investigating, I found that it was a syndicated script that stations could subscribe to and produce themselves. I thought it was really clever, as is so with Doctor Science. I'm going to find out who airs it around here. If no one does, I'll try to lobby for it.

You will no doubt get mail from many readers decrying that program as silly (it *is*), outrageous (yes), unbecoming for professionals like us (darn tootin'), and incomprehensible (not for people with a sense of humor). But you know what? I think it's really neat. Humor, especially the wry, scientific type, requires a very high intelligence. The fact that we appreciate it makes us better than everyone else (or at least certainly smarter)!

So bravo to you. Whenever we start to take ourselves (or our jobs) too seriously, we should think of Doctor Science. I'm going to compile a list of electronics hoaxes for your next April Fool's column and send them to you.

### BOB SCHROEDER

Trenton, N.J.

*The good Doctor sure keeps us on our toes! Unfortunately, KCSM has dropped his program, so I now subscribe to his tapes from Duck's Breath (1-800-989-DUCK).—RAP*

### Dear Bob:

I have also been keeping a list of backpacking equipment. I started in 1987. In 1990, I changed from a simple list to a spreadsheet so I could watch the ounces accumulate into pounds. It's more productive to worry and fret over weight at the keyboard than it is

at the trailhead. It must be a common trait among engineers to measure things and make lists. My wife refers to this as a fault, but she was an art major and must be forgiven for some of her views.

### P.E. FARLEY Melbourne, Fla.

*Your data indicate that the sum of all the weights from the spreadsheet is less than the pack's weight. Which do you believe?—RAP*

### Dear Bob:

I'm on your side in the digital dispute. I complain about overflow or roundoff and am told, "that's not error; that's just the way it works!" Well, according to my Funky Wagnalls, it's error. Would these people be content with jagged lines and purple people on their TV set because "That's the way it works?"

When I get something that's obviously totally wrong I'm told, "It's not computer error, it's just a software problem!" That's little consolation when the computer turns your engine off in traffic. Would these people accept a paycheck that's wrong (on the low side)?

I am told a circuit has to work because the computer simulation says it will. In this case, fortunately, I can breadboard the circuit and it doesn't work. Furthermore, breadboarding takes less time, and when I am done I have a real circuit. Now if the circuit had a million transistors, I would have to simulate it.

What about when I go to the parts place after calling first, and the guy comes up empty-handed. "The computer said we had 10, but the bin is empty." I'm sure somebody punched in the wrong data, or no data at all, but it's cost me my time and cost them a customer if I have an alternative.

And how about the guy who was executed by software? He complained that he was getting too much radiation, but the computer said no, and of course the operators believed the computer.

I'm sure it was a "small problem," except to the patient in question.

I am thankful for my digital calculator when I need more than a few digits of accuracy, but I have found that if I accidentally divide by zero, the only way to ever get it to do something useful again is to unplug it and start over. On the other hand, my analog divider recovers immediately.

My digital scope has great memory and hard copy, but it often displays waveforms totally different from what's really happening. Of course, when I finally figure out the real waveform, I can get a good picture. But if I know the waveform, I don't need a scope.

I keep an analog scope connected, too—the combination works great. My digital spectrum analyzer is many times better than the old analog job, but neither is always truthful.

I love my synthesized function generator with its five digits, but it quits without warning if you set the first two to zero. I have a cute digital clock that is far more accurate than my analog watch, unless you shuffle across the carpet in dry weather to pick it up, in which case it becomes a random number generator. On the other hand, the analog watch does lose a fraction of a second if you bang it hard.

Something is wrong when one gets a reputation for being "anti-digital" just by pointing out known facts. I think it's basically a question of intellectual honesty, which leads to proper use. Computers are powerful, but when they are taken to be infallible we are in for a heap of trouble.

Safeguards, crosschecks, and overrides don't get built in. Mistakes don't get corrected because "It's in the computer." People believe data that should be questioned.

Computers are bad when they make you think you can do something that you can't. The same goes for PhDs (I have one). And professional societies. Some computer advocates are honest about their product and some are right



## PEASE PORRIDGE

down there with used car salesmen.  
**ART DELAGRANGE**  
*Mt. Airy, Maryland*

*Art, you're the most skeptical so-and-so I've seen since I looked in the mirror this morning. Great! Now, can I sell you some Fuzzy Logic?—RAP*

**Dear Mr. Pease:**

Your battery anecdotes reminded me of the new 3.3-V logic standards for computers that operate on batteries and at high speed.

The earliest popular vacuum tubes were the 2-30 and 2-33 with 2-V filaments designed to suit lead-acid storage batteries. Very few people in those days could afford a 2-V battery in a glass jar, plus the charging equipment (Tungar). Instead, two A-size dry cells were commonly used—each about the size of a small thermos—plus a rheostat to drop the voltage back to 2 V.

The Philips 109A tube had a 1.3-V filament (good with a half-spent battery), with about half the current of the 2-30 tube. It ran on a very low plate voltage (I forget how low) and was very economical to operate. The U.S. tube industry never got around to designing tubes to fit widely available batteries. The industry initially picked a 2.5-V filament for ac (before the indirectly-heated cathode). This eventually gave way to the 6.3-V standard that ushered in automobile radios.

Now 60 years later, I see a sea of 3.3-V IC designs intended for battery operation, but I do not see popular battery types that fit this voltage. Hence, we have a repeat of standards sans rationale.

It was recognized at the dawn of computers that to get higher speeds, one must limit the logic voltage swing. In 1955, I was responsible for a 36-bit machine that used germanium DCTL circuits; the arithmetic unit operated at 3 V. The swing was between about 0.01 V (saturated collector) and 0.3 V (base load).

Sometimes not knowing technical difficulties prompts bold (or rash) development decisions. Because it was a solid-state machine in 1955, we needed a memory-access monitor. A CRT would have worked fine. However, a research manager approached me and said he could make an electrolumines-

cent display for \$1000, and the next one for \$150. I ordered two made. The display was delivered and even worked when two lines on the 64-by-64 matrix were excited. And it could even be seen in total darkness with dark-adapted eyes. We also figured that we could not make reasonable-solid-state drivers for it, so we finally used a CRT.

Incidentally, that machine was code-named Solo by the funding agency. It was intended to be operated by a single person and was housed inside a specially-designed desk. Could I qualify as being the first to make a personal computer—at least a solid-state one?

**SY WONG**

*Tarzana, Calif.*

*1955? That's before I built my first Heathkit, so I can't comment on your claim. But you're probably right. All portable computers do rely on switchers for best battery usage.—RAP*

**Dear Bob:**

Yet more on spreadsheets. Duncan Hall and myself developed HandiCalc—a virtual spreadsheet—shortly after VisiCalc arrived as a response to the rise of blind faith in spreadsheets that we were witnessing. Unwilling to emulate pencil and paper, HandiCalc consisted of a pencil and paper (gridded engineering calculation sheets) and was “powered” by a between-the-ears wet processor. Strangely enough, when coupled with an HP 12C coprocessor, HandiCalc outperformed our colleagues' Lotus 1-2-3 NPV calculations, and it was accurate.

Your observation on misused spreadsheets is in fact a special case of Prof. Arthur Williamson's (University of Canterbury) “Reality Failure.” “Reality Failure” is the general case where reality fails to comply with the rules and assumptions imposed upon it by a design engineer. Another special case of “Reality Failure,”—well known to Free-marketeers and Economists—is “Market Failure.”

**ROBIN McNEILL**

*Energy Manager*

*Telecom South*

*Christchurch, New Zealand*

*Better your processor than some of the “wet-behind-the-ears” computer guys. And thanks for pointing out the “Reality Failure” situation.—RAP*

## ULTRA-MINIATURE SURFACE MOUNT

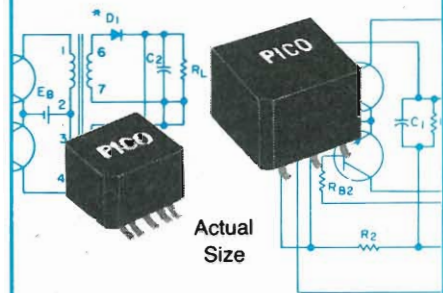

## DC-DC Converter Transformers and Power Inductors

These units have gull wing construction which is compatible with tube fed automatic placement equipment or pick and place manufacturing techniques. Transformers can be used for self-saturating or linear switching applications. The Inductors are ideal for noise, spike and power filtering applications in Power Supplies, DC-DC Converters and Switching Regulators.

- Operation over ambient temperature range from  $-55^{\circ}\text{C}$  to  $+105^{\circ}\text{C}$
- All units are magnetically shielded
- All units exceed the requirements of MIL-T-27 ( $+130^{\circ}\text{C}$ )
- Transformers have input voltages of 5V, 12V, 24V and 48V. Output voltages to 300V.
- Transformers can be used for self-saturating or linear switching applications
- Schematics and parts list provided with transformers
- Inductors to 20mH with DC currents to 23 amps
- Inductors have split windings

Delivery—  
stock to  
one week

See EEM or  
FAX 914-699-5565  
or send direct for  
FREE PICO Catalog

**PICO**  
**Electronics, Inc.**  
453 N. MacQuesten Pkwy. Mt. Vernon, N.Y. 10552

Call Toll Free 800-431-1064

IN NEW YORK CALL 914-699-5514

## WHAT'S ALL THIS GROUND NOISE STUFF ANYHOW?



**BOB PEASE**

OBTAINED A BSEE FROM MIT IN 1961 AND IS STAFF SCIENTIST AT NATIONAL SEMICONDUCTOR CORP., SANTA CLARA, CALIF.

Recently I got a letter from a reader, James Hansen in New Boston, NH. He introduced himself as a digital and analog/digital system design engineer, and said a few nice things about what I write, and then said he had a favor to ask.



I'd like to know how you blue-blooded analog types get those marvelously clear and beautiful low-level waveforms on the scope. I've used everything from crummy scopes through lab-quality scopes, but none of them, regardless of what I've tried, ever produced the squeaky clean displays like the ones I see in the data books.

*When I crank up the gain, there's always noise in my displays - usually common-mode noise - that I don't think is really there, but I am not always sure. I'm talking about a lifetime of experience here, in a variety of locations, equipment and breadboards, not just one system that came down the pike yesterday.*

*I use my very own tried, true, and trusty 465B scope, for which I personally paid Tek some \$2600, years ago. In spite of all the TLC I've given this scope, the 50 mV scale is useless if there is anything besides battery-powered flashlights running in the building.*

*What I find is damped ringing spikes running at either the clock frequency of whatever is under test, or 60 Hz, with the peaks running typically about 3/4 full scale at 50 mV/division, all mixed on top of the real signal. When the gain is backed down to something like 5 V/div, the visual effect is a thick or slightly fuzzy line. This doesn't really bother me much when dealing with large signals, but it is bad news when you need to look at something little.*

*I've shorted the probes with the shortest ground strap available, and I still see the junk by touching the common ground point - or anywhere else on the chassis. Sometimes I can cut down the amplitude of these dudes a bit with tons of bypassing, but I never come close to eliminating it. I've tried using the scope differentially, I've floated it and/or the test bed, played games with various grounding schemes, and a hundred other things, all to no avail.*

*So before I die, just once I'd like to hook my scope to the output of a 12-bit DAC and see those uncluttered, beautiful, sharp, clear 5 mV stairsteps like those in the databooks. Is this possible? Do the databook guys cheat, like, touch up the picture?*

*How does one absolutely, positively know if the junk on the screen is real, or some instrumentation artifact? I've chased this kind of noise for days only to*

# PEASE PORRIDGE

*discover (actually, 'proclaim' is a better choice of words) that it wasn't real. Do other people run into this sort of problem, or am I the only soul on earth cursed in such a way?*

*If you don't care to write the story on this - it would be a boon for humanity - how about giving me some hints, and I'll write it up for publication in the magazine of your choice.*

*Anyhow, this is the challenge. Will you grasp the ring or beg off? With thanks for your past and future good humor, unknowing help, and encouragement! I am, sincerely yours, James M. Hansen, Project Engineer.*

Well, I recognized a guy with a real problem. And it's not just his problem; I'm sure other people have it too. So, remembering the philosophy and the immortal words of LaVerne Baker, "Jim Dandy was the kind of guy, never like to see a pretty girl cry - Jim Dandy to the rescue," I called up Jim Hansen in his lab. I told him I thought I could help him, but this was going to be one of these Onion Syndrome deals - you peel off a couple layers, and cry; then you peel off a couple more layers, and cry some more.

I told him the first thing to do, to get the waveform really quiet, was to put a screwdriver across the master clock in his digital section. He said, after thinking a bit, "Bob, that will cut down the noise a lot, but then I won't be able to get any signal to feed to the DAC, to exercise it." I agreed that was surely true, but if it really did cut down a lot of the noise, that was a good clue. NOW, there may be a little more noise buried *behind* the local noise, but to a certain extent you do have to clean things up, one after another.

If you try one experiment to cut down the noise, and you can't see any improvement, you may have to do that experiment again later, because it was masked by some other source of noise you cleaned up at an intermediate time. THAT's the Onion Effect at work. But, specifically, I told him, his noise is caused mostly by 3 main problems - a noise source, a transmitting antenna, and a receiving antenna. We can improve all 3 of these.

Let's assume that, as an example, we really do want to add a little 12-bit DAC onto an existing digital system, and we want the analog output to be quiet, and we want to be able to SEE that it is quiet, in real-time - not just by the use of some averaging function on a fancy digital scope.

The first part of the problem is to recognize that the digital system is generating a lot of noise, some of it at more-or-less clock rate, with voltages moving 5 volts in just a few nanoseconds, and other stuff at various rep rates. Example: a low-duty-cycle pulse might drive a couple hundred milliamperes of current into a load, for a few microseconds every millisecond. Even if the current's path does not describe a very big *loop* (in terms of area), there will definitely be a big amount of magnetic flux coupled into the air. If the circuit was laid out so the current pulses are routed through adjacent parallel busses for Drive and Return, or through twisted pairs of wires, that can help a lot, though.

Now if you have a bus that is nearby the clock or other fast-rise-time signals, you definitely can get capacitive coupling, and even if you have really good bypass capacitors on your power bus, they will also let the current pulses couple magnetically to your signal. So if you put a scope probe anywhere near the



# PEASE PORRIDGE

computer, the probe can pick up some noises. The electrostatic (voltage-related) part of this noise can be largely eliminated by putting the computer in a sealed metal or copper-clad box. Now you may not want to do that, and you may not be *able* to, but you may not literally *have to* do that. Instead, you may be able to just wall the noises out by putting your DAC inside a smaller metal box, so you literally segregate the DAC from the noisy world. The computer's Digital ground and the DAC's Analog ground should be kept completely separate until you link them together at one point - and that point should preferably be right at the DAC. That way, digital noises will not have to flow through the analog ground system, in general, and they will be shielded away from the DAC and the other analog circuits.

Unfortunately copper or aluminum will not reject or attenuate magnetic noises. You might try some iron, but it may take 1/4 in. of steel to do the filtering if you have 60 or 120 Hz noises, and even 1/16 in. is not really guaranteed to shield out high-frequency magnetic flux. When you are really serious, you may have to buy some mu-metal foil or thin sheeting.

What is the realistic thing to do, then? Well, one thing that does cause magnetic coupling to fall off rapidly is *distance*. You may be able to move the DAC to another board, or another quiet area of your system, farther away from the noisiest digital signals. Or, to be more realistic, if this DAC is going to add into some kind of video display amplifier, you'll want to bring the DAC right over by the load it will drive. That way, after you get the analog signal coming out clean, the signal will be right where you want it. NOW, maybe the DAC has to be driven from a busy computer bus. How can you put the DAC exactly half-way between the busy bus and the pre-amplifier? The answer is, layout. You have to plan and lay it out exactly that way, if that is exactly what you want. For best results, you would indeed have to bring in the digital signals on one side of the DAC, and feed the analog signals directly from the DAC over to its load. But that's still just part of the problem. Let's say you bring your probe over near the DAC, and the scope display is reasonably quiet. But as soon as you touch the probe's ground to the signal ground, horrible noises appear. (This is what I think was Jim's major problem).

There are 3 main aspects of this noise coupling. One, as we have discussed, is to try to get the digital signals to not radiate so much noise; and the SECOND is to try to get less current flowing through the ground path. A majority of scopes have a ground path from their signal grounds, back through the line cord to the ground pin of their power plug. When your scope is plugged in, the ground of the scope is grounded to the building, for safety. But if there is any other source of noise in your building, the noise can couple in through that ground pin. Touching your probe to any other ground enables ground currents to flow through the entire length of the probe, and through the probe's ground wire - a ground loop.

One good thing to do is to use a 3-prong-to-2-prong adapter on the line cord. In some places that might cause trouble or danger, especially if there are high voltages around. But it's worth a try, and this is probably the best way to eliminate 60 Hz ground loops and "ground current." When you do this, hang a fat label on the scope so other users will be warned of this semi-floating condition. Also, be warned that some high-frequency noise currents can still come right in through the power line. Power transformers don't have zero picofarads of capacitive coupling, even the best ones. So a noisy room can still



# PEASE PORRIDGE

cause large currents to flow as soon as you touch the probe to a signal or ground. In an extreme case, you will have to give up on the line-powered scope, and use a battery-powered scope. Still, even a battery-powered scope can have some picofarads from its case to the world, so you can NEVER cut that current down to ZERO. Still, it's worth an effort to see what improvement you can get by this approach. Then we will go on to the best part of the fix.

The best part is to get the probe's ground wire down to zero length. When you buy a scope, the probes usually come with a 6-inch ground wire, a 12-inch ground wire, and a whole fistful of funny little pieces of metal and plastic that you quickly shove into the back of a drawer and never look at again. WELL, it's just about time to dig them out and look at them. They will be helpful.

The major problem in this noise test is that the current noises flowing through the scope's ground wire are generating all the large noises, as they flow through the inductance of the ground wire. Shortening that wire is the main solution. Don't just swap the 4-inch ground wire for the 12-inch wire; that's still bad. Instead, unscrew the plastic ferrule or sheath that protects the tip of the probe.

(Your probes may need to be disassembled a little differently than mine, but they can all get dismantled in a similar way.) Now you see the metal ground sleeve that is wrapped right around the tip of the probe. Look in the bag of probe accessories and see what kind of small clip is in there, so you can run a 1/4" path from that ground sleeve to the chassis or groundplane of your system (Fig. 1). Slap this small clip securely onto the tip of the probe. (if it falls off into the soup and shorts out and wrecks your circuit, we warned you here ....) Then connect the tip of that clip to the signal's ground. The noise will be improved by a factor of 20 or 50 compared to what you had before. The main point is, not only is the inductance of the ground strap reduced by a huge factor, but also the coupling of the current into the loop comprised by the probe tip and its ground. That's why probes work so well in the first place.



If you can't find those little probe accessories, you are not in trouble. Form and wrap a piece of bus wire (#20 or 18?) around the ground sleeve of the probe, say, 3 or 4 turns. Then solder that loop to your system ground (Fig. 2). Curl another piece of thin bus around the small wire of the probe tip, about 3 turns, and tack-solder that to your signal. Then you can slide the probe into those sheaths, and let the weight of the probe hold it there. You will have a very short ground path for the price of a penny - and you can fabricate it yourself in just a few seconds, any time you need one!



When I pointed this out to Jim he said, "Why isn't this written down anywhere?" I pointed out that I did mention this in my Troubleshooting book\*, on page 15,

# PEASE PORRIDGE

that if you want to see clean step response with a scope probe, you have to use this VERY SHORT ground path; and that it is also good for minimizing the pickup of noises in the air, too. Maybe I did not emphasize that as much as I should have!

Now, if you called up the applications engineers at Tektronix or any other good scope company, and ask the right question, they would surely be helpful and give the right answer. But you have to know how to ask the right question. Is it written down anywhere? Maybe there are some books on how to use your scope wisely. Not very many.

Now that you have made this major improvement, you will usually want to go back and try all the other experiments, to see which aspects of layout, scope floating, transmitter loops, guarding, shielding etc., will *now* make the biggest improvement on the observed noise. Because things that made no effect before, can make a difference now.

These inductively-coupled noises will never match exactly if you use 2 probes, so that explains why you could not run the scope preamp differentially to get the noises to cancel. However, John Christensen in our apps group pointed out that you can usually improve this inductively-coupled noise by a couple more octaves, by running a separate, heavy ground wire from the scope to the system ground. If you can get *most* of the ground current to flow in this path, rather than the probe's ground wire, that's where you can get an advantage. Nick Johnson suggested also that a high-frequency FET probe is usually designed with very short ground paths and will thus be good at rejecting noises, also.

Now, let's say you can look at the ground and it's reasonably quiet. Then you look at the DAC output and it is noisy. There are about five new places to look.

1. Does the DAC have a quiet power supply? Many DACs have a PSRR of 70 or 80 dB - at dc. At 5 or 10 MHz, if the PSRR is as good as 6 or 3 or even 1 dB, it's a miracle. Look at the noise on that power supply. Are you feeding a +5-V digital- power bus to your DAC, with 87 mV pk-pk of noise on it? And then complaining because the noise on the output of the DAC looks only a little less bad than the 87 mV? For shame!
2. You can try some heavy bypassing. Sometimes a couple 0.1  $\mu$ F disc capacitors, plus 10  $\mu$ F of tantalum, plus 220  $\mu$ F electrolytic, can cut the noise to an acceptable level. (And remember, only YOU can decide what that is ... "good enough" is not necessarily anywhere near "perfection"). If the bypassing alone does not work, then:
3. Try some decoupling resistors, perhaps 33 or 120 ohm, or ?? even a ferrite bead, in series with the path of the power from the supply to the DAC. If this is not enough improvement, try:
4. A *completely separate* set of twisted-pair wires from the power supply to the DAC. Put 100 ohm in series with that wire.
5. Try a completely separate power supply for the DAC. Repeat all the bypassing. Maybe one or more of these things will solve the problem; maybe none of these will help right now, but they may help later. Remember the Onion Syndrome.

## PEASE PORRIDGE

And finally, sometimes the DAC is fed signals from a noisy set of busses that are all-the-time jostling and buzzing, and there is talk-through from these busses into the DAC output. Don't be surprised; there is almost never a spec on that, and this talk-through can be LOUSY. The solution is to make sure the DAC gets its digital signals through a set of drivers or buffers that are running off the same quiet power supplies that the DAC is getting. The bit lines that the DAC sees can get a *lot* quieter, thus reducing the talk-through effects.

One of the things I like to do is to bring the signal right to the scope. It avoids the 10x attenuation and the possibility of bad phase compensation of the 10x probe; and it avoids the bandwidth limitation of the 1x probe (most of them have barely 10 MHz of bandwidth, and mediocre settling time) and it avoids the capacitance of shielded cable. If you can bring your system to the scope, that has some great advantages, and I recommend it. Maybe you cannot do that. But, it's usually not essential.

What if you do all these things and there is still a little more feedthrough from some systematic noise than you can tolerate? Maybe after you have done all these things, it's time to go back and find out exactly WHAT signal is making the noise, and try to figure out how it is coupling in. Is it a current flowing through a big loop? Maybe that loop can be closed up, or you can use twisted pair or coax cables to get minimum transmitter effect from that signal. Maybe it is capacitive crosstalk from a couple adjacent pc-board runs, and the signals can be shielded or guarded.

This is probably a good time to mention a book by John Barnes, "*Electronic System Design: Interference and Noise-Control Techniques*."\*\* It's quite good, practical, and offers several excellent ideas for many kinds of practical problems. He gives a number of good examples throughout. I am delighted to recommend this book; in some respects, it can be considered as a companion to my book on Troubleshooting.

What if you try all these things and there's still some vexing noise, and you turn off the clock and turn off the *power supply*, and there's still that noise there! Well, that sure gives you a clue, doesn't it? Noises can get conducted into your system by the power supply leads. Maybe you should UNPLUG your power supplies. Certain kinds of noises are brought in by your soldering iron, so, you may unplug THAT, and/or move it several feet away. Transformers for power supplies AND soldering irons can generate a lot of 120/180/360 Hz noise that couples insidiously (magnetically) into an otherwise low-noise system.

And DVMs are often pretty noisy, whether or not they are connected to your signal, so try turning that off. Is there a computer or terminal nearby? Turn that off, too. As you can see, this is rapidly turning into a game of, "Is there anything that *cannot* be causing that noise?" Maybe that flashlight of Jim Hansen's really is the only item that is unlikely to be the culprit. (And if you shine *that* on a diode, the light can cause dc currents to flow.) Anyhow, at least we have shown that it probably is NOT the oscilloscope causing all that high-frequency noise, all by itself. It's just a matter of, do you want a good antenna, or do you want a minimum antenna that will reject the noises in the air!

Now, did that help, Jim? Jim says YES. He was enough of a good sport to admit that part of his noise was caused by an oscillator that he had built up several months ago. He had quit using it, but had never disabled or disconnected it from power. He'd forgotten all about it, until these troubleshooting tips led him to the source of the noise. A second source of noise was a transformer whose flux was coupled into a signal fed to a high-gain preamp. The 180 and 360 Hz waveshapes were a dead give-away.



# WHAT'S ALL THIS FREQUENCY-TO-VOLTAGE CONVERTER STUFF, ANYHOW?

Once upon a time—my gosh, it was 30 years ago—a guy asked me if I could show him how to make a Frequency-to-Voltage converter (FVC). Well, at that time, at George A. Philbrick Researches, we knew a lot about analog computers and we figured we could convert almost any signal to any other form or mode. So I designed a charge-dispenser made of a voltage limiter, a capacitor, and diodes. I built it up, and it worked pretty well.



**BOB PEASE**  
OBTAINED A BSEE FROM MIT IN 1961 AND IS STAFF SCIENTIST AT NATIONAL SEMICONDUCTOR CORP., SANTA CLARA, CALIF.

And in 1964 we put this into the old Philbrick Applications Manual.<sup>1</sup> (Fig. 1).

The first amplifier has a limited output voltage. The p-p voltage across the capacitor is pretty well established:

$$V_{p-p} = 2V_z + 2V_d - 2V_d$$

So, the charge ( $Q = C \times V_{p-p}$ ) flows through the feedback resistor of the second amplifier. The output

voltage will be, on the average:

$$V_{out} = R_f \times C \times V_{p-p} \times f$$

A few years later, we got into the Voltage-to-Frequency Converter

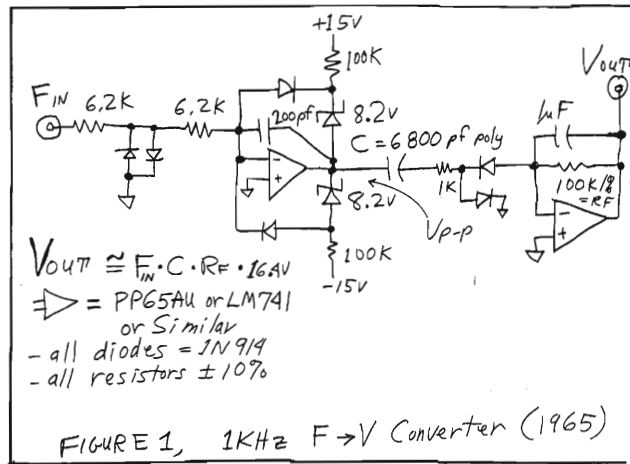

(VFC) business. At the same time, I came up with an improved circuit for an FVC (Fig. 2). The input comparator is set up to accommodate TTL signals, but if you put a resistor from the + input to -15 V, you can accommodate symmetrical signals; a resistor from the + input to ground will cut down the hysteresis and let you handle small signals.

But the real improvement in this FVC is the bleeder resistor, the 3.3 M $\Omega$  added to the right end of the capacitor. If you want a charge dispenser to dispense a constant amount of charge, no matter what the rep rate of the pulses, you can't let the voltage at the

right end of the capacitor just sit there unattended. That's because it will be charged (through the nonlinear impedance of the diodes) to a different voltage, depending on how long you wait. The 3.3-M $\Omega$  resistor helps pull charge off that node, so the p-p voltage is always constant at high or low speeds.

That is what's required for good linearity—for minimum deviation from the straight line of:

$$V_{out} = k \times F_{in} + (\text{error})$$

Also, note the symmetrical Zener clamp.<sup>2</sup>

Another cute feature was the adaptive filter at the summing point of the second amplifier. The conductance of the diode is linearly proportional to the current through it, so the 1- $\mu$ F capacitor gives an adaptive time constant and helps filter the signal

more at low frequencies, less at high frequencies. That's the classical problem with most F-to-V converters: If you want to get low ripple, you get slow response due to the heavy filtering. If you want fast response, it's hard to get

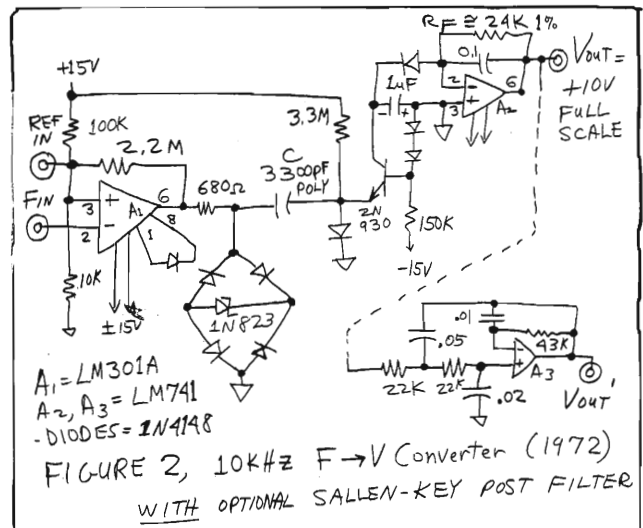



# PEASE PORRIDGE

low ripple.

After I left Philbrick, I joined National and designed the LM131 voltage-to-frequency converter<sup>3</sup>, using completely different ideas than any of the Philbrick circuits. It used  $Q = I \times T$ , rather than the  $Q = C \times V$  employed by all of the Philbrick ones. It didn't need  $\pm 15$  V; it could run on +15 or +30 or +12 or +5 V—much easier to apply. BUT, it still had the same constraint when you used it as an F-to-V converter: If you want low ripple, it's hard to get fast response.

In 1978, I wrote an application note on how to improve the response time of an FVC—in the Linear Apps Handbook.<sup>4</sup> I showed how to cascade two or more fast Sallen-Key filters to give reasonably quick response, yet filter out the ripple at 24 dB per octave. For example, if you have a frequency in the range 5 to 10 kHz and the frequency suddenly changes, you can get the output voltage to settle to the new level (within 1%) in about 40 ms—that's about 200 cycles—yet the ripple will be less than 5 mV p-p. That's about a 10:1 improvement over a single R-C filter. Good, but not good enough for some applications.

In 1979, I wrote another App Note<sup>5</sup> showing how to use a phase-locked loop to make a quicker F-to-V converter, about 2 ms. That's about 10 cycles of the new frequency—a further 20:1 improvement.

Not bad—but still not fast enough for everybody. For example, in a control loop, you may need a voltage that represents the frequency, and any delay or lag in the information may cause loop instability. So a fast response can be very important.

Recently, a guy asked me how to make a 60-Hz FVC with quick response and negligible lag or delay. I told him that the standard procedure is to use a fast clock and a digital counter. But the number of counts collected during one period is linearly

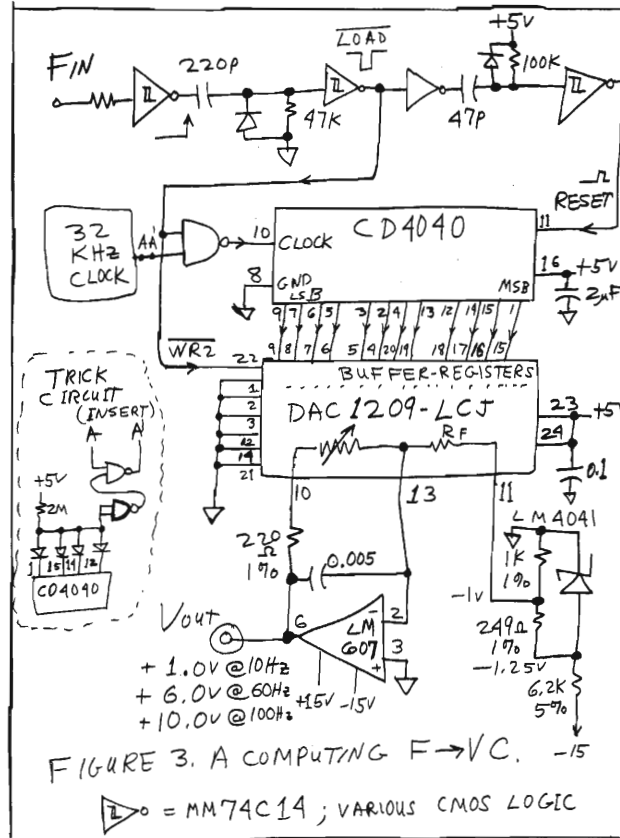

proportional to the period of the signal, and you might have to do some digital computations to convert that to a signal representing the frequency. Then I realized that a “multiplying” DAC can be used to divide in a reciprocal mode.

I built it up and it worked. This Frequency-to-Voltage converter settles in *one cycle* of the frequency. Besides that, it uses only a small number of parts (Fig. 3)

The digital logic generates a couple of pulses at the time of each rising edge of the incoming frequency (you could use some kind of dual one-shot multivibrator, but I didn't have any of those around). The first pulse loads the data from the CD4040 into the DAC (the pulse also disables the path from the clock to the counter to avoid any confusion from rippling in the counter). Then the second pulse resets the counter.

The MDAC has storage registers built in, so the data from the counter is fed right in to the DAC when the WRITE-2-bar pulse is applied. The MDAC isn't connected in the normal

way, with the variable resistance in the input path. The fixed resistor is in the *input*, and the impedance controlled by the Digital code is connected as the *feedback resistor*. This permits the multiplying DAC to act as a *divider*, so the reciprocal function is done neatly—not in the digital realm, and not in the analog world, but on the cusp between them. (More on this in a few months). The LM607BN was chosen for the op amp because you need low offset. It's cheap,  $V_{os}$  is only 25  $\mu$ V typical (60  $\mu$ V max.), and you don't need a trimmer pot.

The guy who asked me for this function was quite pleased, as he said there are several suppliers who are happy to sell you this function for a couple hundred dollars.

But it's really not that big a deal. You can do the whole thing yourself. All it takes is just a few dollars worth of parts and a little labor.

The main limitation of this scheme is getting a decent resolution on the output voltage if you must cover a wide range of frequencies. For example, if you have to cover a 10:1 range, let's say from 20 to 200 Hz, then you can only use a clock frequency of 20 kHz with a 10-bit counter (or the clock counter would overflow, giving unacceptable false answers).<sup>6</sup> Then at 60 Hz, the number of counts would be just 333. The resolution would be only one part out of 333, or one-third percent.

So, if 200 Hz is scaled for 10 V, 60 Hz for 3 V, and 20 Hz for 1 V, then the FVC can only resolve the difference between 60.18 Hz and 60.000 Hz—for example, 3.000 V and 3.009 V. The resolution at 200 Hz would be even worse, about 100 mV per step, because there are so few COUNTS there.

If you need to get better resolution, you can get a 4X improvement by using a more expensive 12-bit MDAC

"EXCESS  
INVENTORY  
EDUCATES  
KIDS"

Turn your excess inventory into a substantial tax break and help send needy kids to college as well.

Call for your free guide to learn how donating your slow moving inventory can mean a generous TAX WRITE OFF for your company.

Call **EAL**  
708-690-0010

Peter Roskam, Executive Director

P.O. Box 3021, Glen Ellyn, IL 60138 Fax (708) 690-0565

Excess inventory today...student opportunity tomorrow

**PEASE  
PORRIDGE**

and a 80 kHz clock. An 8-bit MDAC, even though the price is right, can't give much better than 1% resolution, even if you use it in a dynamic range of just one octave.

So, there's the limitation to this counting method. But you have to admit it is fast and has low ripple! (Of course, the other limitation is that if you wanted a fast computation for a 60-kHz frequency, you might need a 20 or 80 MHz clock and counter, not impossible, but not so easy....)

All for now. / Comments invited!  
RAP / Robert A. Pease / Engineer

Address:  
Mail Stop C2500A  
National Semiconductor  
P.O. Box 58090  
Santa Clara, CA 95052-8090

p.s. And in an upcoming column, I plan to write about Voltage-to-Frequency converters, too.

References:

1. Teledyne Philbrick, Applications Manual, 1965, 1985; p. 95; (out of print).
2. How do you like that little Zener bridge circuit that's inherently symmetrical in its swing? As near as I can tell, it was first published by NSC in an "Applications Corner" in *Electronic Design*, p. 69, July 5, 1976. I sort of invented it about 1971—has anybody ever seen it before 1976? I don't think I have ever seen any patent on it—and if there had been one, it would have expired by now....
3. LM131/LM231/LM331 Voltage-to-Frequency Converter data sheet; available on request.
4. National Semiconductor Linear Applications Handbook; Appendix D, available on request.
5. Ibid., Application Note AN210.
6. That's the function of the trick circuit shown in Figure 3—to detect when the counter is nearly full, shutting off the clock. This prevents preposterous outputs when the frequency approaches zero.

**Data-Entry  
Terminals**

**Rugged Operator Interface  
For Industrial  
Applications**

FREE!  
Custom Labeling



QTERM-II  
\$235  
(7-24)

- Easy-to-read 4x20 display.
- Handheld or panel-mount.
- Tactile 40- or 24-key keypad.
- Programmable LEDs for status indicators and operator alert.
- Easy configuration lets you program every key with up to 255 characters.
- RS-232, RS-422 or RS-423 interface.
- Optional bar-code wand interface.
- Inexpensive batteries supply power for months. Can also be externally powered.
- FREE! Custom labeling of logo and top keys make this a part of your product.

**QSI**  
CORPORATION

2212 South West Temple, #46  
Salt Lake City, UT 84115 • USA  
Telephone: 801-466-8770  
(Fax: 801-466-8792)

CIRCLE 142 FOR U.S. RESPONSE  
CIRCLE 143 FOR RESPONSE OUTSIDE THE U.S.



# BOB'S MAILBOX

**Dear Editor:**

This is a response to the challenge thrown out by Bob Pease in the May 13 issue for a practical example of Fuzzy Logic. Bob, look no further than yourself. In case that sounds like an insult, it might be better to say that we should "look no further than *ourselves*." Most of our reactions to everyday events are fuzzy. We are neither entirely deterministic or stochastic beings; we apply variable judgment to virtually all of our inputs, and act accordingly.

In the quest for more intelligent behavior from our hardware, we are recognizing the need for electronic systems to be more adaptable. What one calls this approach to design is not the point. I agree that the term "Fuzzy Logic" is nowadays used like "transistorized" was a couple of decades ago, but surely Bob, you understood back then it was just a way of saying "*tres moderne*." There was substance to the claim (that is, transistors *did* provide a more forward-looking solution than vacuum tubes, wouldn't you say?) but it was unduly stressed.

Fuzzy Logic is simply that branch of electronic system design that seeks to cope with uncertainty more effectively than a rigidly programmed logical structure could. As one who scorns the predictability of even a scientific calculator, you ought to be a fan: Instead of being bound to the confines of a certain "yes" or "no" mediated through one-bit variables, Fuzzy Logic admits to the possibility that "the truth" (or at least the best estimate) may lie somewhere in between. Digital radio channels routinely make use of Fuzzy Logic within their DSP to continuously determine the optimal conditions for minimum bit error rate.

I believe we are at a juncture where the development of highly adaptive, richly interconnected, quasi-analog, nonlinear, signal-processing structures (though only loosely related to contemporary Fuzzy Logic implementations) will be essential to the emergence of more "intelligent" non-or-

ganic companions. Is that important? You would be singularly oblivious of long-term trends not to recognize the potential impact of such on society.

**BARRIE GILBERT**  
*Fellow, ADI, IEEE*  
**Analog Devices**  
**Beaverton, Ore.**

*Barrie, you have my permission to use F.L., or adaptive controllers, or human thought, or any other not-necessarily-linear control system. I'm just cautioning about Fuzzy people who brag and exaggerate unconscionably. Look in IEEE Control Systems magazine, June 1993, p. 5-7 for cases where other people are objecting to overzealous F.L. claims. And thanks for the EXAMPLE of F.L. within digital radio channels.—RAP*

**Dear Mr. Pease:**

Three quick points about your column on Fuzzy Logic.

Fuzzy Logic is Threshold Logic: This is easy. Just look at how it is implemented. Minima and Maxima of Sums is Threshold Logic.

Threshold Logic Computes Probabilities: Instead of True/False bits in and True/False bits out, what we have is probabilities in, probabilities out.

Synthesis of Threshold Logic Circuits is Efficient: Thanks to the Binomial Polytopes, polynomial-time Threshold-Logic circuit synthesis is a reality. Hence, if instead of computing bits we wish to compute probabilities, Threshold Logic, a.k.a. Fuzzy Logic, is the way to go. It is also clear that in most cases, the computation of probabilities is NOT what is required. Many times, however, it is the only way to go.

**SILVIO URSIC**  
**Ursic Computing**  
**Madison, Wisc.**

*Isn't it funny that F.L. people say "probability" when they mean proportionality!—RAP*

**Dear Bob:**

Sometimes I agree with you, and sometimes I don't. But I must say that

you're right on target regarding Fuzzy Logic. I have been studying the literature on Fuzzy Logic since I first heard the name a few years ago. Our library has considerable information on the subject (mostly in trade journals), and I have yet to read of a single application in which a properly designed and configured digital controller would not provide equal or better performance.

I will concede that Fuzzy Logic is interesting conceptually, and there is a certain curious familiarity with it (probably because the human mind is a bit fuzzy itself). Your comment that you have no documented evidence, either in the form of a workable circuit/controller or a legitimate comparison between performances appears to be a valid one. I, too, have seen much brouhaha and little factual information regarding performance. I look forward to the proof, as pointed in your column. Here's to keeping them honest...

**J.J. BRADSHAW**  
**Electrical Engineer**  
**University of Missouri-Rolla**

*I am really finding some special (nonlinear) cases where F.L. shows advantages. But for general-purpose linear controllers, most claims of F.L. superiority are just hype.—RAP*

**Dear Bob:**

Your article on Fuzzy Logic in the May 13 issue was right on the mark! After studying the hype on this technique, I came to the following conclusion: *Fuzzy Logic is to control design what PLC ladders are to computer programming.*

If a designer is limited to a choice of a "bang-bang" design versus a Fuzzy Logic black box, he can probably do better with the Fuzzy. However, if he can apply analysis and a bit more sophisticated hardware (and perhaps some software) he can beat or at least equal the Fuzzy design.

If he needed transition functions and rules for his design to be competitive, then Fuzzy Logic is forcing him to do some analysis that he should



# High Voltage 20¢/Volt

The PS300 programmable power supply series provides up to 5kV at 25 Watts for laboratory and ATE applications. These supplies offer a wide range of features including programmable current and voltage limits, selectable overload response, and short circuit protection.

Dual LED displays monitor both output current and voltage, while a third display allows error-free front panel entry. A full GPIB interface is available for ATE systems.

The combination of features, price, and performance make the PS300 series the perfect choice for laboratory or systems use.

---

**\$1150**

---

PS350	0 to 5kV
PS325	0 to 2.5kV
PS310	0 to 1.25 kV

---

25 Watts output power  
0.001% regulation  
0.1% accuracy  
Low output ripple  
Dual polarity  
Voltage and current readouts

---

GPIB Interface \$495

---



## Stanford Research Systems

1290 D Reamwood Avenue, Sunnyvale, CA 94089  
TEL (408) 744-9040 FAX 4087449049 TLX 706891 SRS UD

CIRCLE 260 FOR U.S. RESPONSE  
CIRCLE 261 FOR RESPONSE OUTSIDE THE U.S.

## PEASE PORRIDGE

have done in the first place.

**ROBERT M. STANLEY**

*Los Gatos, Calif.*

*I'm still looking for real examples.—RAP*

**Dear Bob:**

I have read your column for some time now and find myself in almost total agreement with most of what you say. However, I think you have ignored a major problem with most electronic designers these days. Most of the younger technicians and engineers have never smelled ozone! I have been in the field of high-power broadcasting for 17 years now, and like Tim Taylor of "Home Improvement," I believe the answer to most problems is *more power*. Most of these young whipper-snappers have never experienced the thrill of having a 25,000-V, 10-A plate transformer arc over right next to their head. Shucks, most of these guys don't even know what an ARC is!

Modern electronics don't even smell right. Most of us broadcast engineers freely admit that we got into the field strictly for olfactory reasons....we love the smell of hot insulation and PCBs! (By PCBs I mean Polychlorinated biphenyls, not printed-circuit boards!)

I was born and semi-raised in Silicon Valley back when it was Vacuum Tube Valley. We have forgotten that wonderful heritage.

Silicon is wimpy stuff compared with the heavy iron and copper associated with transmitting tubes. (I suppose a more politically correct term would be thermionic devices.)

Mind you, I have no objection to modern digital circuits; we use scads of them in the broadcast field. But I think some of the younger folks could benefit from an internship in traditional high-power RF technology.

I guess I'd better close now. I'm feeling a little weak and need to go back to the shop for another snort of ozone.....Ahhhhh.

**ERIC P. NICHOLS**

*Director of Engineering*

*KJNP AM FM TV*

*North Pole, AK*

*More power can be fun and educational, but I'd hate to be designing an electric car with a 25,000-V battery and vacuum-tube controllers.—RAP*



# WHAT'S ALL THIS DOUBLE-CLUTCHING STUFF, ANYHOW?

**R**ecently, a pair of California Condors were released into the wilds of the San Geronio wilderness area of Southern California. This was a significant event, because there had been Condors flying around those mountains from the year 60,000,000 B.C. to 1986 A.D. But in 1986, the naturalists convinced the California Fish and Game Dept. that to prevent the Condors from going extinct, they had to capture all of them and put them into protective custody until the breeding stock had reached a viable level.

For six years, these naturalists tried

various approaches to bring the number of Condors to a healthy status, and they did finally succeed. One of the important tricks they used was whenever Mama Condor would lay two eggs, one of these naturalists would sneak in through a trapdoor, remove an egg, and put it in an incubator. The Mama would look down and decide to lay another egg, since the number of eggs didn't look like a very large number. (Appar-



**BOB PEASE**  
OBTAINED A BSEE FROM MIT IN 1961 AND IS STAFF SCIENTIST AT NATIONAL SEMICONDUCTOR CORP., SANTA CLARA, CALIF.

ently Condors aren't as smart as crows, which can count up to 5 or 6 fairly consistently.) Anyhow, by this procedure, the Condor families were tricked into raising two clutches of eggs—one that the family would raise,

and another that would be hatched and raised by the naturalists, behind the scenes. This trick was called, "Double-clutching."

Now, if you have driven old cars, or trucks, or sports or racing cars, you will be amused at this play on words. That's because double-clutching is also a procedure to save wear and tear on your gearbox, and on your clutch, at the expense of a little extra work for your left leg. What exactly is double-clutching (or, as the British call it, "double de-clutching"), and why is it significant?

Let's say you're accelerating in second gear. When you're ready to shift into third, you decide not to use the standard approach, which is just to tromp on the clutch, take your foot off the gas, shove the shift lever into third, and let the clutch back out. Instead, you opt to double-clutch properly:

First, you take your foot off the gas and kick in the clutch. You shift into neutral, AND let the clutch out. You wait perhaps 0.3 to 1.0 seconds for the engine to slow down from its high revs, depending on how fast you were revving when you started to shift and how much inertia the engine has to slow down. THEN you kick in the clutch and shift into third, and let the clutch out quickly, feeding the gas appropriately. If you have judged it right, when you let the clutch out, there isn't any JERK. And when you shove the lever into third, the gears and engine are at a synchronized speed, so there's minimum wear on the synchronizers, which are the tiny clutches that bring the clutch plate and the gears into smooth synchrony. There's also usually less wear on the clutch plates.

What's the big deal? The main point

is that when you try to shift into third gear, the engine has slowed itself and the clutch plate down to the right speed—just about the same speed as the gearbox—so it saves wear on the synchronizers and the clutch. It can also save shock and strain on the whole drive-train, because the speeds are just about synchronized when you let out the clutch.

Well, big deal, you say. Cars haven't needed double-clutching since the synchromesh transmission was popularized 50 years ago. Why bother? Why fool around with anachronistic motions? Isn't it just buying trouble? Even Tom and Ray Magliozzi\* claim that double-clutching is silly and stupid and wasteful of energy. Ah, but I can give you reasons why it is beneficial.

First, in most cars, the actual gears are always in constant mesh, and the synchronizers only decide which pair of gears to connect to their shaft. But many trucks and some racing cars are still set up with a non-synchromesh gearbox. With trucks, because they have so many gears, it's noticeably more efficient not to have all of the gears in mesh all of the time. So with the "crash-box," you HAVE TO double-clutch, or you will not be able to shift. The same holds true for racing cars—to gain the last couple percent of efficiency, only one set of gears is in mesh at any time, and you have to actually synchronize their speeds or you can't get it in gear. Despite the obvious drawbacks of having to double-clutch, the gearbox is stronger and more efficient than a comparable synchromesh one, and has less tendency to overheat.

Other reasons for double-clutching: Because it is the right way to operate the clutch. Because it saves wear and tear on your synchronizers in the long run, if you're planning to run your car over 200,000 miles, as I do. Because it is fun to do. Because in *very* cold weather, ( $-10^{\circ}\text{F}$ , for example) you may *have to* double-clutch to shift gears at all, at least for the first few miles.

One very important reason is that, if your clutch linkage ever fails, you can still shift and get home by double-clutching, getting the engine and

## PEASE PORRIDGE

gears' speeds synchronized and then just EASING the shifter into the right gear. In the last 1,050,000 miles of driving VWs, I have lost my clutch about 3 times, and each time, with careful planning, I've been able to drive home safely. One time I pulled into the Customs House at Calais, Maine, and discovered my clutch was out. I eased

along carefully and managed to get all the way home, 350 miles, to Boston, where it was convenient to put the car in the shop to have the clutch repaired—much more convenient than in the middle of a vacation, or the middle of Maine.

Another reason is that on some old cars, first gear isn't synchromesh, so if

you need to shift into first without coming to a full stop, you have to double-clutch. Also, a lot of cars these days are made with weak, chintzy synchros, so they soon wear out, and to drive them gracefully, you need to double-clutch.

Note, when down-shifting, you have to shift into neutral and then *blip* the throttle momentarily before you shift into the lower gear. It requires practice and a good feel, a good touch, to do it right, especially considering the embarrassing noises you make if you miss your shift into a low gear on a crash-box. For example, you should aim to have the revs just a little high, so if you miss, the engine will soon slow down, and then gears will be at the right speed to mesh and the cogs will slip in....

OKAY, Pease, I'll try this double-clutching some day; but why do you bring up all *this* stuff in an electronics magazine? Ah, there's an excellent analogy: In most conventional switching regulators, the power transistor turns on while there's lots of voltage across it, and after it turns off, the voltage usually increases to a large voltage. When the transistors turn on, the diodes are already carrying significant current, and the transistors have to turn the diodes off. This is all somewhat stressful, and causes the transistors and diodes to have large turn-on and turn-off surges—pulses of power on every cycle. Of course, diodes and transistors have been designed to withstand these stresses and surges with excellent reliability; we see them all the time.

Still, people have specially designed "resonant mode" switchers to have zero-voltage and zero-current switching. In these regulators, most turn-on and turn-off stresses are eliminated, because the transistor is at a very low voltage when you turn it on, and at a very low current when you're ready to turn it off. Consequently, most voltage and current transients are greatly decreased. Less filtering and shielding is therefore required, enabling the complete regulator to have low Radio Frequency Interference (RFI). Now, to design such a supply takes a more complicated controller IC, more expensive parts, a very careful layout, and a lot of expertise in the electrical design. So

# "YOUR FREE CATALOG KNOCKED MY SOCKS OFF"

We get that sort of comment all the time. People are impressed that our free Consumer Information Catalog lists so many free and low-cost government booklets. There are more than 200 in all, containing a wealth of valuable information.

They tell you how to make money, how to save money and how to invest it wisely. They tell you about federal benefits, housing and learning activities for children. They fill you in on nutrition, health, jobs, and much, much more.

Our free Catalog will very likely impress you, too. But first you have to get it. Just send your name and address to:

**Consumer Information Center  
Department KO  
Pueblo, Colorado  
81009**

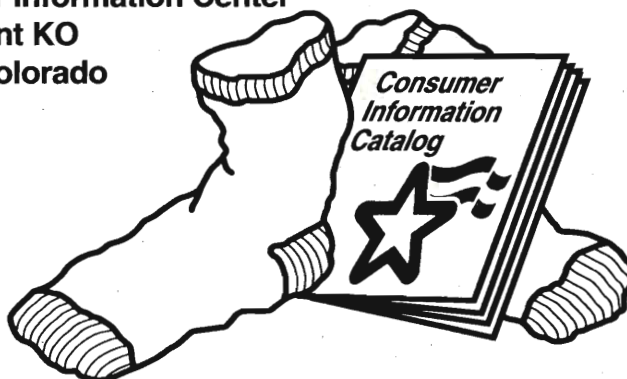

A public service of this publication and the Consumer Information Center of the U. S. General Services Administration



## PEASE PORRIDGE

while you get some advantages, you have to pay for them.

Now, when you want to build a compact, high-performance, switch-mode regulator at switching frequencies up to about 1 MHz, conventional switchers can do at least as well as resonant ones in terms of cost, size, and performance. But if you need a switcher even smaller and faster than that (most users do not), when the switching frequency rises above 2 MHz, the resonant-mode switchers begin to show real advantages.

At this time, National doesn't make these resonant-mode switchers, so I can't offer you any detailed info about all of their advantages and disadvantages. But I have explained most of their key features. And now you can see why the smooth, stressless turn-on and turn-off of the transistors and diodes in these resonant-mode switchers are analogous to double-clutching your shifts.

All for now. / Comments invited!  
RAP / Robert A. Pease / Engineer

Address:  
Mail Stop D2597A (note change!)  
National Semiconductor  
P.O. Box 58090  
Santa Clara, CA 95052-8090

P.S. Even if you double-clutch your shifts most of the time, as I do, do you know when it's a good idea NOT to double-clutch? My primary answer would be either when you're in complicated traffic and you don't want to fool around, or when you're really struggling on an upgrade and a speed-shift prevents you from losing speed. So, as it is with every rule, you should be aware that there are times when the rule doesn't apply. Some day I'm going to write a book about that topic....

\*CAR-TALK, on many National Public Radio stations, is a wild mixture of automotive wisdom and entertaining banter about cars that's hosted by Tom and Ray Magliozzi. I tune in nearly every Saturday morning. Ask your local NPR station for their broadcast time—if you like *my* stuff, you'll probably like *theirs*.



## You Need Tree City USA

City trees add the soft touch of nature to our busy lives. They cool our cities, fight pollution, conserve energy, give wildlife a home, and make our neighborhoods more liveable.

The trees on city property, along streets and in parks, are an essential part of the urban forest. To keep these trees healthy and abundant, your town needs an organized program for their care...an annual action plan to plant and prune the city's trees, and to maintain their health.

Support Tree City USA where you live. For your free booklet, write: Tree City USA, The National Arbor Day Foundation, Nebraska City, NE 68410.

 **The National  
Arbor Day Foundation**



## DATA ACQUISITION

TransEra's 400 Series plug-in data acquisition boards transform your PC into a high-speed, high-precision system for a wide range of scientific test, measurement and monitoring applications.



The 400 Series combines all of the essential elements necessary for a complete data acquisition system, including: DMA sample transfers from 50 to 200 KHz, up to 14 bit analog input and output, digital I/O, and counter-timers—all on half-sized cards for ISA 8 and 16 bit busses.

When you add HTBasic development software, you have the most powerful data acquisition system available for PC operation. HTBasic runs HP BASIC programs and offers advanced features like instrument control, data analysis, and graphic presentation capabilities.

So, put a powerful data acquisition system into your PC with TransEra's 400 Series plug-in boards and HTBasic. Find out more today.



## TransEra

Engineering Excellence for 15 Years™

3707 N. Canyon Road • Provo, UT 84604  
(801) 224-6550 • Fax (801) 224-0355

CIRCLE 144 FOR U.S. RESPONSE  
CIRCLE 145 FOR RESPONSE OUTSIDE THE U.S.



## PEASE PORRIDGE



# BOB'S MAILBOX

**Dear Bob:**

I very much enjoyed your column, "What's All This Taguchi Stuff, Anyhow? (Part II)," which appeared in the June 10 issue. A major function of a voltage regulator is to make a steady output voltage when faced with changing input voltage.

Taguchi ignored this major function and managed to design an active voltage divider. After looking at the circuit optimized by Mr. Taguchi, I think that a passive voltage divider made from a few resistors could have done the job about as well. A cheap, simple, and reliable passive design like this would reduce the "losses a product imparts to society" even more.

In the zeal for demonstrating his tool, Taguchi threw out a major function of a voltage regulator, throwing out reality and thus losing sight of what tools are for—to help design and build REAL products. It seems that the tool has become more important than its use.

He goes on to demonstrate his disconnection with reality a second time—the optimization showed the output to be much more stable than the reference, and alarm bells didn't go off in his head!

Perhaps there are useful techniques to be extracted from the Taguchi method. Too bad they are all mixed in with so much horse exhaust. Even worse, the proponents of the method don't know that anything smells.

Keep up the good work, and keep encouraging us to get our hands dirty by using the best circuit simulation tools available—the parts and a soldering iron, along with a good dollop of understanding and common sense.

**DONALD BOROWSKI**

*Hewlett-Packard Co., Spokane Div.  
Liberty Lake, Wash.*

*Thanks, Donald. We agree on many things. But a resistive divider would work just as badly as Taguchi's "optimized regulator" in a TV set.—RAP*

**Dear Bob:**

Regarding your recent column on Taguchi.....

YES!

**BOB DOBKIN**

*Vice President, Engineering  
Linear Technology Corp.  
Milpitas, Calif.*

*Eloquent, man! Thanks.—RAP*

**Dear Bob:**

Your recent article "What's All This Taguchi Stuff, Anyhow? (Part II)" was an absolute *classic*. I hope you've succeeded in opening the eyes of at least a few of the followers of the pious Dr. Taguchi and his acolytes.

**FRANK LATOS**

*Duo Systems Inc.  
Farmington Hills, Mich.*

*Thanks for your perceptive comments. I could never have zapped them like that if they hadn't taken themselves so seriously!—RAP*

**Dear Bob:**

Thank you for a most entertaining diatribe, re Taguchi (Pease Porridge, June 10, 1993). On the instinctive level, it seems obvious that a regulator cannot produce a stable output voltage with such lack of dependence on the circuit's component values. How does it get to know what 115 V is, then?

Can it somehow pluck "115 V-ness" out of thin air and match its own output against that? If Taguchi were an engineer, he would have realized that this was what he's asking his "optimized" circuit to do. I would be embarrassed to even claim it.

Logically, something internal to the circuit has to be ACCURATE. A good design reduces the need for accuracy down to a minimum of well-controlled components.

These components (resistors, Zeners, etc.) may be part of a feedback loop for improved circuit "robustness" against outside stimuli and can be

cheap, but they are the core of the circuit and constitute the reference. So, Taguchi can design a regulator without a reference. Hmm....

Whenever someone such as Professor Barker starts to talk about selecting transistors for Beta (or  $h_{FE}$ ), alarm bells immediately ring. This is basically the last thing you want to do. It's going to be expensive come production, and the designer will regret it. I don't mind someone specifying a minimum  $h_{FE}$  in their design, but never a maximum.

Any design has to cope with the full gamut of parameters that the transistor's spec cares to fling at you, and it's safer to assume that a component manufacturer will aim high in terms of  $h_{FE}$ .

Anyway, what happens to this selecting  $h_{FE}$  policy under the conditions of varying temperature? I shudder to think what an environmental proving program would reveal on a Taguchi/Barker circuit.

The great danger of such charlatanism is that it might be believed. There are students out there with no internal reference against which to check the thinking.

Students are stuck with having to believe what they're taught. Back in my university days, I would have swallowed it.

Worse still for us engineers is the potential for gullible managements to insist such gymnastics can be performed. There are companies managed by people who are only too willing to believe in panacea, and then make it look bad for engineering if it cannot enact the miracles. Tail wags dog.

Thanks for your column—it provides a stable reference against some pretty major external perturbations. Long may you continue to unmask the perturbators.

**PAUL J. ROBERTSON, BSc.AMIEE**

*Principal Engineer*

*GEC-Marconi*

*Basildon, Great Britain*



## PEASE PORRIDGE

*You're right! If Taguchi's circuit did meet the system needs, it would not be cost-effective, but VERY EXPENSIVE. I have no idea where he got the notion that tight selection of Beta saves money! In high-voltage transistors, Beta does not get high, anyhow.*  
—RAP

**Dear Robert:**

I've read your articles with great pleasure for many years. I especially enjoyed your "Taguchi, Parts I and II." I had lunch with G. Taguchi in Kansas City last month during a speaking tour, which I think was to promote his latest book. He's not a

terribly interesting luncheon mate, believe me (I think he was being paid by the word, and he was getting close to his budget). But he got quite animated when I asked if there was any truth to the rumor that he was going to appear on "Larry King Live" later that week.

I've often wondered why the Japanese hold the writings of these gurus in such high regard, and with such little scrutiny. An answer was suggested—of all places—by a response that Dr. Dean Edell, M.D., gave to a question posed by a caller to his daily radio talk show: "Why doesn't any significant medical research come out of Japan?" Dr. Edell made the observation that Eastern cultures foster a strong reverence for their elders, and that scrutiny and criticism, which are an integral part of the Western scientific method, are considered rude and disrespectful. This may explain why Taguchi's writings are full of errors and omissions.

For an honest, straightforward approach to optimizing designs, I would recommend Keki R. Bhote's book, *World Class Quality (Using Design of Experiments to Make it Happen)*—ISBN 0-8144-5053-9—AMACOM, 135 W. 50th St., New York, NY, 10020. It uses a common-sense approach to minimizing output variations and doesn't obfuscate the process with bizarre functions or orthogonal arrays. It's a good one. I should know, I've got a Master's Degree...in *Science!*

**JONATHAN JAMBOR**  
Wichita, Kans.

*I won't fault Taguchi for not being a great conversationalist, but on everything else... I agree that Mr. Bhote's book is excellent—he uses graphs, statistics, and common sense to solve problems that Taguchi's Experts never could. He talks about "knobs" that engineers can grasp to control systems. My kind of thinking—I recommend it.—RAP*

# "YOUR FREE CATALOG KNOCKED MY SOCKS OFF"

We get that sort of comment all the time. People are impressed that our free Consumer Information Catalog lists so many free and low-cost government booklets. There are more than 200 in all, containing a wealth of valuable information.

They tell you how to make money, how to save money and how to invest it wisely. They tell you about federal benefits, housing and learning activities for children. They fill you in on nutrition, health, jobs, and much, much more.

Our free Catalog will very likely impress you, too. But first you have to get it. Just send your name and address to:

**Consumer Information Center  
Department KO  
Pueblo, Colorado  
81009**

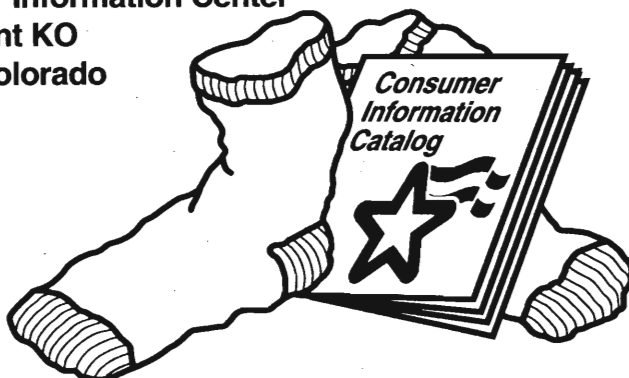

A public service of this publication and the Consumer Information Center of the U. S. General Services Administration

Want to say hello to Bob Pease in person? He'll be at Electronic Design's Wescon booth 7803/7804, Sept. 28-30, to meet with readers. Details of his schedule will be posted at the booth.

# WHAT'S ALL THIS FEMTOAMPERE STUFF, ANYHOW?

While back, I mentioned<sup>1</sup> that we needed a clean test fixture to measure an operational amplifier's input current in the low femtoampere region. But aside from a neat little integrating capacitor made of copper and air, what else did we need? Here's a list:

- A circuit to let us make a high-resolution measurement.
- Ultra-low-leakage sockets.
- A relay to reset the integrator.
- A box to hold and cover up the whole thing.
- A little computer to interpret the data.
- And a scheme for calibration.



**BOB PEASE**  
OBTAINED A BSEE FROM MIT IN 1961 AND IS STAFF SCIENTIST AT NATIONAL SEMICONDUCTOR CORP., SANTA CLARA, CALIF.

you can't do that if the amplifier is unable to measure anything when it's not plugged in. A further weakness is that when you try to measure the current at the amplifier's + input, the equation for  $dV_{out}/dt$  says that the amount of stray capacitance at the +

If we take one op amp and force it to integrate the current at its negative input, it can do that job quite well (Figure 1). But what if its socket is leaky? How can you tell if the error is the leakage of the amplifier or the leakage of the socket?? You'd like to be able to autozero that socket's leakage error out of the circuit. But

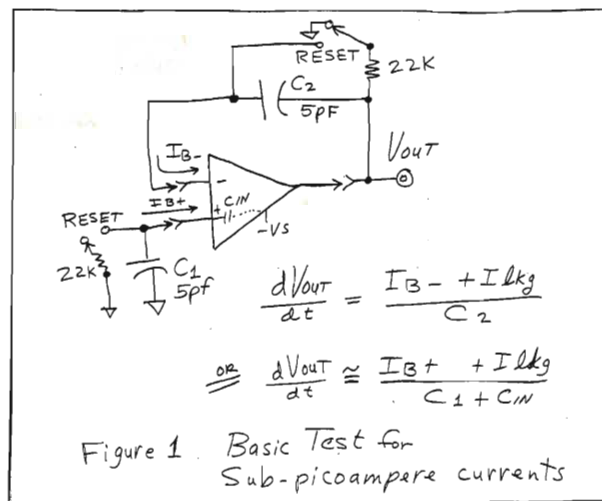

input affects the scale factor. So, the circuit of Figure 1 would not be very practical.

Let's move on to Figure 2. Here, we use two low-leakage amplifiers to test both inputs of one op amp—the Device Under Test, or DUT. When the DUT is removed, the socket leakage and fixture leakage can be calibrated out, in an auto-zero cycle, so long as they are small and stable. However, this scheme is excellent primarily because we can pretend to plug in a DUT without actually plugging in anything, and then say, "What is the bias current of this amplifier?" The answer had better be ZERO, give or take a few dozen attoamperes (an attoampere is  $10^{-18}$  amperes, about 6 electrons per second). Now, in this circuit, the voltage at the + input and at the - input are both

constant voltages, so the capacitance from these nodes to ground don't affect the accuracy of the measurement.

Of course, we have to get some good test amplifiers with low noise. The LPC661 and LMC662 are quite adequate, with only small femtoamperes of input bias current that doesn't drift much, and not much noise.

We also need some insulation. If we can't use a lot of Teflon (as I mentioned in my Teflon column) what can we use?

Well, we can use some air. It does not leak much, if you only have a little of it. Now, if you have a lot of air, it may permit "leakage" of some electrons, occasionally, due to cosmic rays. But if we keep the total amount of air around the delicate nodes down to a couple cubic inches, that's not so bad. The other material we like to use for an insulator is the body of the plastic-DIP ICs. This has

an impedance up near  $10^{16}$  ohms, which is about as good as you need. If the part gets dirty, or dusty, or gets fingerprints on it, just wash it in your dishwasher and you can get the pack-

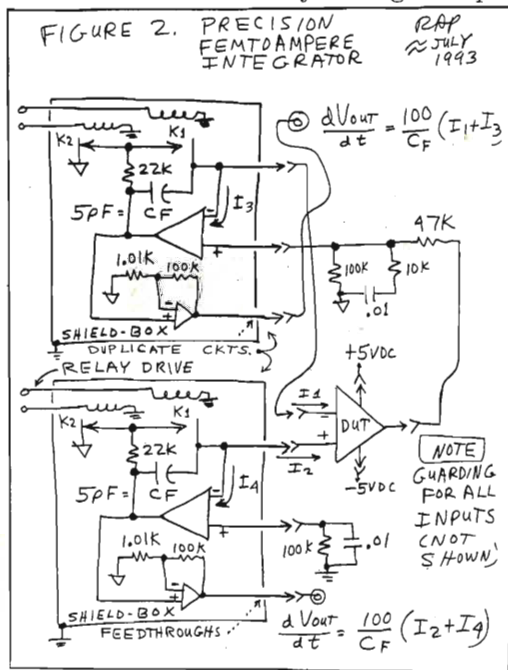



# PEASE PORRIDGE

age back pretty close to when it first came out of the molding procedure. When you buy an LMxxx in a plastic DIP package, untouched by human hands, it's really a *very* clean package. Ceramic DIP packages, on the other hand, aren't nearly as low in leakage, more like  $10^{14}$  ohms—not very good for precision work at sub-picoampere levels.

How about a socket? Can you buy a good Teflon<sup>2</sup> socket? If you could, that might simplify things. However, for many IC packages, you can't buy one, so you'll just have to make one, which is MUCH better than anything you can buy.

If you make a pc board in the pattern shown in Figure 3, and then solder some little component jacks<sup>3</sup> onto the printed-circuit lands, you can get a socket with less than a femtoampere of leakage, due to the guarding. The guard ring is at the same voltage as the inputs, give or take a couple of millivolts, so there's no direct leakage path from the power-supply buses to the inputs. (Additional notes on guarding are found in various NSC data sheets, such as LF198 or LMC662, available on request.)

As long as those sub-femtoampere leakages are fairly constant from one minute to the next, accuracy won't be hurt at all. This pc board can be made of Teflon material or polyimide if the highest precision is

needed. Even glass epoxy board material usually works very well, due to the guarding *on both sides* of the foil.

How do you make a low-leakage capacitor? In the earlier column, I said that we had made a big 5-pF air-dielectric capacitor with copper-clad walls. For the improved version, we made a *small* box with copper-clad walls, still about 5 pF, and there's NO detectable leakage from one plate to the other. When we made a little Teflon capacitor out of several inches of Teflon-insulated twisted-pair wire, well, that also was up near  $10^{17}$  ohms. Not bad. We evaluated both of these and they both worked well. But my sneaky technician is always trying to find something a little better than my best idea. He tried a 4-inch segment of Teflon-insulated coax cable. In terms of dielectric absorption, it was not quite as good as the air capacitor. But in terms of spurious jumps, it was better, as there was a minimum amount of air around the summing point with fairly optimum shielding. So, once again my technician outsmarted me! I love it!

Okay, wise guy, where do you buy your relay? Or do you make *that*, too? Well, we were prepared to make or modify an unshielded relay, but we were able to buy a standard Coto relay, model 1240-12-2104.<sup>4</sup>

This model has a shield between the coil and the reed, which seems to cut down the capacitance to about 0.1 pF.

Then turning the relay off does not really couple very much charge at all into the summing point, electrostatically.

Additionally we shield and guard everything so that there's a wall between the input and the rest of

the relay (K1).

Then we add another relay K2 to ensure that the other end of the relay is held at 0 volts during the test, even if the integrator's output goes off to 2 or 3 volts.

So, the  $10^{14}$  ohms from one end of the reed to the other has no effect, since there's never any voltage across the relay during the test. Also, we drive the relay's coil with the minimum amount needed for pull-in and drop-out—not 12 volts and 0 volts, but 5.5 volts and 2 volts. This helps decrease the jumps.

What do we do to compute the result? We have a Teradyne tester programmed to read the integrator's delta  $V_{out}$  over six 10-second periods. If any 4 give about the same data, it's programmed to admit that the data are valid. We're prepared to ignore cases when a JUMP occurs. But if it's too jumpy, we just reject that part. Right now, after a preliminary study of a few thousand parts, we have yet to find a really bad part at the 20-femtoampere level. That's encouraging, both from the standpoint of the fixture and the amplifier.

How do we put this all in a box? We use a lot of copper-clad to help us build up boxes of every necessary size to shield out all electrostatic interference. We keep power transformers FAR away to cut down on magnetically-coupled noises. We set up four channels of femtoampere testing to look at all four inputs of a dual op-amp. We made things modular, so we can easily pull out a test channel or a socket for cleaning—or for replacement. As with any precision tester, we're reasonably meticulous in our assembly.

We guard the power-supply leads away from the signals and the inputs, because any mechanical motion of the power-supply bus can couple into the summing points. After all, as  $Q = C \times V$ , we say that by definition  $I = dQ/dt$ . Now normally, the major component of  $dQ/dt$  is  $C dV/dt$ , but there is also a term  $V dC/dt$ . If there is a big voltage—such as 5 volts—then  $V dC/dt$  can be a significant term.

For example, if  $dC/dt$  is 0.01 pF per millisecond, due to vibration of

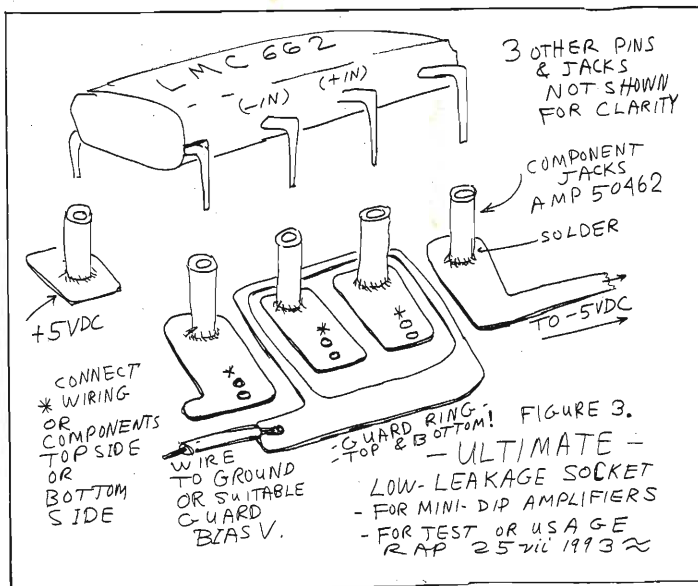



## PEASE PORRIDGE

wires, then  $5\text{ V} \times 0.01\text{ pF}$  per milli-second can cause a "noise" of 0.05 pA, or 50 fA. That "noise" goes away if you guard the power-supply buses, and/or if you prevent unwanted motion or vibration.

How do we calibrate the fixture? For a full-scale signal, you can add in a current through a capacitor. In other words, you can get a full-scale signal from this setup by applying a 0.1-volts-per-second ramp to a 1.0-pF capacitor, which represents 100 fA or 0.1 pA. We have an old General Radio standard capacitor, type 1403-K, accurate to 0.1%.

To get calibration at the "Zero" level, do not insert a DUT, close up the box, and do the test. The number of femtoamperes during this "dummy test" should be consistently the same as during an "autozero" test, so the delta should be very small, down in the noise, and consistently below 1 fA. That's important.

We think we can get good results in production with this fixture, although it's pretty early. We can't say that every problem has been vanquished, but we're sure we can solve every problem.

All for now. / Comments invited!  
RAP / Robert A. Pease / Engineer

Address:  
Mail Stop D2597A (note change!)  
National Semiconductor  
P.O. Box 58090  
Santa Clara, CA 95052-8090

1. "What's All This Teflon Stuff, Anyhow?," *Electronic Design*, Feb. 14, 1991
2. Teflon is a trademark of E.I. DuPont de Nemours
3. Type 50462; AMP, P.O. Box 3608, Harrisburg, PA 17105
4. Coto Corp., 55 Dupont Dr., Providence, RI 02907.

Want to say hello to Bob Pease in person? He'll be at Electronic Design's Wescon booth 7803/7804, Sept. 28-30, to meet with readers. Details of his schedule will be posted at the booth.

# FAST Amps & Buffers

- Bandwidth (GBP) 100 MHz > < 1 GHz
- Slew Rate 1000 > < 7000 V/ $\mu$ s

Calogic's fast op amps and buffers offer the best of both worlds, pin for pin replacements to industry standard devices as well as more efficient and wider bandwidth devices.

## Checkout the Product Line:

### Bipolar Transistor Input Buffers

Part No.	S/R (V/ $\mu$ s)	SS BW (MHz)	I <sub>out</sub> (mA)	Price (\$)*
CLM4121	4000	180	200	1.95
CLM4125	3500	300	80	1.95
CLM4102	3000	200	160	1.85
LH4002	2500	200	60	3.75
CA2003	1200	50	200	1.65
CA2033	1200	50	200	1.65
LM6121	1200	50	200	1.89
LH4001	200	30	100	2.75
LH0002	200	30	100	2.75

### FET Input Buffers

Part No.	S/R (V/ $\mu$ s)	SS BW (MHz)	I <sub>out</sub> (mA)	Price (\$)*
CLM4109	7000	250	250	4.95
CLM4163	6000	150	1000	4.95
CLM4133	4000	200	150	3.25
LH0033	1500	100	150	9.75

### Fast Op Amps

Part No.	I Bias ( $\mu$ A)	V <sub>os</sub> (mV)	S/R (V/ $\mu$ s)	SS BW (MHz)	Price (\$)*
CLM6181	5/1.5	5	1400	100	2.99
CLM4132	200pA	5	650	150	6.85
CLM4124	10	5	500	100	3.75
CLM4152	200pA	5	500	100	10.50
CA2020	40/15	10	300	50	3.53
LH0032	200pA	5	500	100	10.50

### General Op Amps

Part No.	I Bias ( $\mu$ A)	V <sub>os</sub> ( $\mu$ V)	S/R (V/ $\mu$ s)	SS BW (MHz)	Price (\$)*
OP-07	4nA	75	0.3	1	1.43
OP-27	40nA	25	2.8	1	2.29
OP-77	2	25	0.3	1	0.80

Price per "N" package style

\*100 piece quantity

## Compare the Performance:

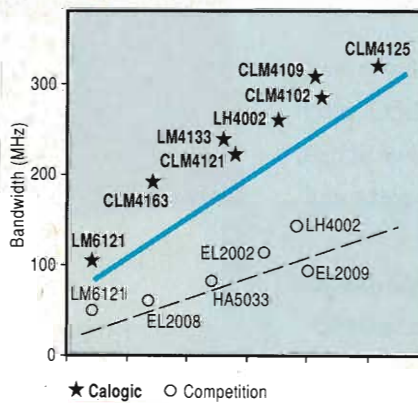

Our new line of wideband buffers and amplifiers out-perform the competition 3X:

**On Performance**  
**On Price**  
**Customer Service**

For **FAST** product, **FAST** samples, **FAST** data sheets, **FAST** response and **FAST** results, call us...

**Phone: 510-656-2900; Fax: 510-651-3025**  
237 Whitney Place  
Fremont, CA 94539

**calogic**  
CORPORATION

CIRCLE 268 FOR U.S. RESPONSE  
CIRCLE 269 FOR RESPONSE OUTSIDE THE U.S.



## PEASE PORRIDGE



# BOB'S MAILBOX

**Dear Mr. Pease:**

I hope you realize what you have just done: You have secured from Dr. Genichi Taguchi the most significant statement ever made by anyone on the application of Taguchi methods: "We are not interested in any actual results..." From now on engineers should understand that this "Taguchi stuff," as you called it, is simply a game of "virtual quality" (which, like "virtual reality," is exciting and engaging as long as the goggles and gloves are on, and the player does not have to worry about what's going on in the real world).

And I would suspect thousands of those who have paid good money for Taguchi books, Taguchi courses, Taguchi workshops, Taguchi videotapes, Taguchi software packages, and what have you, would all of a sudden see the light and ask for their MONEY BACK—and that's "loss to society"!!

**T.N. GOH**

**Professor**

**National University of Singapore**

*Gee, that sounds like a NET GAIN to society to me.—RAP*

**Dear Bob:**

Last week, after reading your column "What's All This Taguchi Stuff, Anyhow?" in the June 10 issue, I was in a local *Computer Literacy* book store and came upon a Taguchi Methods book.<sup>1</sup> I purchased it, and have made some notes for your interest.

Perhaps of greatest interest to your readers is the book's chapter 11: "Tolerance Design and Analysis of Audio Circuits."<sup>2</sup> The authors applied Taguchi Methods to the selection of resistors and capacitors in a third-order high-pass filter, which used one op-amp (assumed ideal), 4 resistors, and 4 capacitors.

As usual, the Taguchi Method was used in two stages: first, the "optimum" nominal values of each resistor and capacitor were determined; then, "optimum" tolerances for each compo-

nent were selected. The goal was to assign component values and tolerances so that the circuit met its specifications with minimum variability.

To find the optimum nominal values of the eight components, the transfer function of the filter was computed in terms of R1-R4 and C1-C4. Three possible values of each component were chosen, giving  $3^8 = 6561$  different circuit possibilities. Then "Taguchi methods" were used to design an "experiment" whose objective was to find the best or optimum circuit among these 6561 different choices of R1-R4 and C1-C4, but by using only 27 runs, not 6561.

Two specifications were defined: the roll-off of the gain at 300 Hz versus the gain at 1 kHz, (-3 dB min) and the amount of peaking at 700 Hz versus the gain at 1 kHz ( $\pm 1$  dB max). Surprisingly, there was no spec for mid-band gain; the only two specs concern gain ratios (roll-offs).

Then the Taguchi Method was implemented. After some Latin-square orthogonal-array monkeying around, the Method calculated that the optimum component values are: R1 = 15 k, R2 = 100 k, R3 = 5.6 k, R4 = 10 k, C1 = 0.022  $\mu$ F, C2 = 0.022  $\mu$ F, C3 = 0.015  $\mu$ F, and C4 = 0.022  $\mu$ F.

Next, the assignment of tolerances was undertaken. The original tolerances on resistors were 2%, and tolerances on capacitors were 10%. The Taguchi Method concluded that capacitors C3 and C4 should be tightened up to 5% tolerance; C1 and C2 can remain at 10%, and R1-R4 can remain at 2%.

Emboldened by your column, Bob, I decided to play the role of Doubting Thomas: Is it reasonable that these two specs required 2% resistors and 10% capacitors to get a working, production-worthy circuit? My intuition said, "No."

So I decided to select the components myself, using traditional (non-Taguchi) methods. My goal was to use 10% resistors and 20% capacitors, and

still get 100% of all filters to meet both gain roll-off specs.

If this is possible, then the circuit could be manufactured much more cheaply, resulting in lower costs, higher sales, and in the words of Taguchi, smaller "loss to society."

I used about the same set of  $3^8 = 6561$  possibilities as the Taguchi investigators. I just chose a different final set of circuit values—R1 = 12 k, R2 = 100 k, R3 = 5.6 k, R4 = 10 k, C1 = 0.01  $\mu$ F, C2 = 0.015  $\mu$ F, C3 = 0.01  $\mu$ F, and C4 = 0.022  $\mu$ F.

I checked out my design by performing some computations. When you insert different component values into the transfer function for this circuit, it's easy to see their effect upon the response, and to see if a particular set of components passes or fails the roll-off specs.

So, using Monte Carlo techniques, with 10% nominal resistors and 20% capacitors, I generated 50,000 different high-pass filter circuits. I was pleasantly surprised to see that all 50,000 circuits "passed" the roll-off specs, using those low-cost parts.

Then I decided to check out the Taguchi-Method-derived circuit, as it was supposedly "optimized" for reduced variability. Maybe it would also yield 100% when 10% resistors and 20% capacitors were used? Here's my results: 73 of 50,000 high-pass circuits using Taguchi-optimized values failed the 300-Hz test, and 1243 failed the 700-Hz test. In other words, yield for the Taguchi-optimized circuit was 97.4%, when low-cost component tolerances (10% resistors, 20% capacitors) were used.

Bob, I am disappointed. The Taguchi Methods gave a circuit that requires *higher-cost* components to achieve 100% yield. Conventional (non-Taguchi) design procedures produced a circuit that had a yield of 100% when *lower-cost* components are used. Maybe some of your colleagues who advocate the Taguchi method can explain what went wrong?



# PEASE PORRIDGE

1. Taguchi Methods (Proceedings of the 1988 European Conference), Elsevier Applied Science, London & New York.

2. Ibid., Chapter 11, authored by N. Logothetis and J.P. Salmon, p. 111.

**MARK JOHNSON**

**Los Altos, CA**

*Well, that is a good question! I always wondered if the Taguchi "optimization" methods really provided an optimum. I wonder where Mr. Logothetis got his "optimization" computer programs. Did he develop them himself, or get them from Mr. Taguchi, or from Taguchi's American Supplier Institute? Not that I care. AND this is NOT the first time that a Taguchi-expert claimed he "optimized" a circuit, when all he did was improve it a little (Phadke, Madhav, Quality Engineering using Robust Design, Prentice-Hall, Englewood Cliffs, N.J., 1979, p. 185-187). Personally, I usually use a circuit with 3 resistors and 3 capacitors to make a simple Sallen-Key filter. The response specified does not require 4 Rs and 4 Cs. I have not yet proven that I can't do it with 2 resistors and 2 capacitors. But I did check Mr. Johnson's computations, and I agree that his math is correct, and his optimum values are as good as he said, for 100% yield with cheap 20% capacitances.*

*NOTE: Mr. Logothetis' optimization study apparently covered and "bracketed" Mr. Johnson's "optimum," but failed to recognize it. Logothetis had the better optimum right in his sights—but failed to pull the trigger! I wonder why. I guess it just goes to show, thinking and checking your results beats trusting your computer any day.*

*NOTE: The Taguchi enthusiasts like to use a minimum number of computations—just 27 or 54 runs. Mr. Johnson decided to run several tens of THOUSANDS of runs. Who's living in the past?*

*NOTE: For a circuit that needs 5% capacitor tolerance, you have to buy good 2% capacitors so they do not drift out of a 5% spec versus time or temperature, and those capacitors really are expensive. Maybe the real "loss to society" is spending \$72 on a book that says you must use tighter tolerance*

*components when cheaper ones will actually do just fine.....—RAP*

**Dear Mr. Pease:**

I am very interested to hear about Dr. Taguchi's comments on the "voltage regulator" that does not regulate. Let me point out a statement in a book, *Introduction to Statistical Quality Control* by Douglas C. Montgomery, Wiley, 1991, p. 543, regarding the specific methods of experimental design and data analysis used in the Taguchi approach to parameter design:

"On the other hand, many companies have reported success with the use of Taguchi's parameter design methods. If the methods are flawed, why do they produce successful results? Taguchi advocates often refute criticism of the methods with the remark that 'they work.'

We must remember that the 'best guess' and the 'one-factor-at-a-time' methods will also work, and occasionally they produce good results. This is no reason to claim they are good methods. Most successful applications of Taguchi's technical methods have been in industries without a history of good experimental design practice. Designers and developers were using the best-guess and one-factor-at-a-time methods (or other unstructured approaches), and since the Taguchi approach is based on the factorial design concept, it will often produce better results than the method it replaces. In other words, the factorial design is so powerful that even when it is used inefficiently, it will work better than most anything else."

So when Taguchi and his disciples wish to slough off criticism of their methods, they argue that "they work." But when Taguchi wishes to brush off criticism of his results, he says it is only the optimization method that is important. Can Taguchi have it both ways? Not after June 10, 1993. (Myself, I like the *Blind Squirrel Theory*—even a *Blind Squirrel* can find a nut occasionally. In some cases, I prefer *Monte Carlo Analysis* because it's easy to do and it searches at random places in the interior of Component Space, not just around the perimeter. But in other cases, factorial methods

*are indeed suitable, and efficient.—RAP*

Also in the same book, same page, author Montgomery observes, "A final point concerns the learning process. If the Taguchi approach to parameter design works and yields good results, we may still not know what has caused the result because of aliasing of critical interactions. In other words, we may have solved a problem (a short-term success), but we may not have gained *process knowledge*, which could be invaluable in future problems."

**NAME WITHHELD ON REQUEST**

*I agree completely: If we trust a computer to process a huge stack of data, and it spits out a good answer (and, as we have seen, that is not a trivial matter), we have neither learned what's right nor how to go in the right direction next time. We haven't developed a feeling for the derivatives, because Mr. Taguchi told us not to bother with those—they are too difficult. He wants to keep us in the dark, and not to develop our intuition. He just wants us to trust him, and to use his method, and trust the results it puts out. Hey, maybe it's Mr. Taguchi that is the *Blind Squirrel!* Further, if there's any false data in the input deck, we would never realize that was what caused funny outputs. Taguchi's analysis is not likely to spot that a typo error is causing false results.—RAP.*

**Dear Bob:**

I cringed when I read the letter (name withheld) in the May 27 Bob's Mailbox, praising the "degreed engineer." I'll give you my experience for what it's worth.

I run a small electronics engineering company in the North of England. Two of us design our products, both software and hardware. We both learned by "reading hobby magazines" and generally devoting ourselves to the subject at hand.

Actually, we've been reading the magazines since we were kids and I'm now approaching 40. I know very little about higher mathematics and virtually nothing about laminar flow. But our speech products have won awards from the chip manufacturers, and our



## PEASE PORRIDGE

single-chip designs are in use in demanding applications the world over.

Ten years ago, we developed a videotape control system so sophisticated that the press found it necessary to call it "an amalgamation of Japanese and American technology," though it was developed from scratch in the one-time mining area of Newcastle Upon Tyne in England.

Since then, we have gone from product to product with no help from universities or outside bodies. Our latest product has received a glowing review from Jerry Pournelle of BYTE magazine, as well as virtually every U.K. computing magazine.

I have run local computer clubs in my spare time and I know technical folk worldwide. I'm not showing off, but am qualifying my viewpoint: I firmly believe that when it comes to producing the goods, the only difference between a "highly qualified" expert and a self-taught expert is a piece of paper. What *is* important is dedication, clear thinking, and more dedication. You will often find lots of that in duly-qualified engineers, but only because it was there in the first place.

I certainly wouldn't want to put anyone off going for qualifications. By all means, it will help your salary and enrich your knowledge. But don't think for a minute that a piece of paper is going to turn an ordinary guy into a star designer... absolutely not! Never has, never will. Name NOT withheld!

**PETER SCARGILL**

*Newcastle Upon Tyne, England*

*Normally I shriek and holler in favor of clear thinking, but I'll admit that dedication is an essential ingredient!—RAP*

**Dear Bob:**

The idea that a degree somehow makes a person a better worker is absurd! Also, the fact that someone has a degree from an unaccredited or unrecognized school does not mean that person is a bad worker.

For part of my two years as an Army draftee, I worked as an "electrical engineer assistant." My degree was in physics, with only one class in electronics. I worked side-by-side with several EEs, including one from MIT. There was one other draftee

whose degree was in physics.

Both of us physics graduates had learned electronics by hands-on personal experiments. The EEs learned all they knew in the classroom and limited lab work. Yet it turned out we physicists could run circles around all of the others.

The need for a degree is, in my opinion, very overrated. When will industry and government recognize that pay should be related to performance? There should not be any artificial pay caps based on education. If the person has the knowledge and experience to get the job done correctly and in a timely manner, that person should be paid the same as another without reference to education.

At this time, I have 38 years of experience, which has qualified me in ways no classroom at any level can do. But I am (obviously) over 40 and therefore "outdated." People forget that we "old-timers" have not only all that work experience, but also have read—yes, studied—thousands of pages of technical material and books to keep up.

Yet a new hire today that has a PhD can be hired at a higher grade than I am, despite the fact that many new PhDs don't have the foggiest idea what goes on in the real world of work. Performance is NOT the name of the game in many places. It is too often *who* you know and not *what you know how to do* that gets the cake.

Now don't get me wrong. Education serves a very useful place. But on-the-job education is also very useful. The point is that automatically separating engineers and technicians based solely on "formal" education, and ignoring the real-world, on-the-job education, is the cause of too much arbitrary discrimination.

**GORDON SIMKIN**

*La Luz, New Mexico*

*I'll pay for a can-do guy everytime, but the world does generally pay a premium for educational status, all things being equal. I can't change the world.—RAP*

**Bob:**

In the May 27 issue, your column had a letter from an individual who complained about the whining of non-degreed engineers. Your answer

proved what I have often suspected: You truly are a sanctimonious cretin!

You stated, "*I don't find all that much correlation between the degree and the abilities. Surely a lot of degreed engineers can't remember how to compute the rms value of a lumpy waveform.*" I can't believe this! Just how many non-degreed engineers do you figure can compute that? If you do a little checking, you'll find that almost without exception those who claim that degrees are of dubious value are those who don't have one (but wish they did). Similarly, I have observed that those with only bachelor's degrees often feel graduate degrees are not needed. (Gee, Bob, see any correlation there??)

Engineers with graduate degrees have learned design and analysis techniques that those without degrees (or those only with bachelor's degrees) have never even heard of. How many non-degreed engineers have a sufficient mathematics background to design digital filters with attenuation-band adjustments? Or to design multifunction pipelines, lead-lag compensators, etc.?

...The purpose of this letter is not to vilify non-degreed engineers; it is simply to put things into perspective. There are gainful employment opportunities in the engineering field for people with little formal education and for those with PhDs. But, this doesn't mean all should be accorded the same status or prestige. If non-degreed engineers want to be treated the same as degreed engineers, then they should stop whining, get off their behinds, and go to school.

**NAME WITHHELD (DISGUSTED)**

*I'm sorry, but I don't agree with you at all—not on anything. Almost every "non-degreed engineer" knows five or ten amazing, useful things that you or I couldn't hack. Good for them! Everybody knows something! Aren't you glad I'm not your boss? I'm glad you aren't my boss.—RAP*

Want to say hello to Bob Pease in person? He'll be at Electronic Design's Wescon booth 7803/7804, Sept. 28-30, to meet with readers. Details of his schedule will be posted at the booth.

# WHAT'S ALL THIS ESD STUFF, ANYHOW?

**R**ecently a guy asked me to present a lecture to the Silicon Valley ESD Society—a lecture about ElectroStatic Discharge. That's a little like bringing coals to Newcastle—what the heck could I tell *them* that they did not already know? I did know how I would start out. But after the beginning, then what? And if I wrote down everything I told them, would that make a useful, valuable column? Let's see....

First I told them about the ESD newsletter we started at National a few years ago. The purpose was to inform all of the engineers of new developments so we could meet high levels of ESD on our new ICs with a



**BOB PEASE**  
OBTAINED A BSEE FROM MIT IN 1961 AND IS STAFF SCIENTIST AT NATIONAL SEMICONDUCTOR CORP., SANTA CLARA, CALIF.

minimum amount of wasted effort. Jolly good. Shortly after that, the editors posted a list of the ICs that would survive a very high ESD rating. We were exhorted to go out and learn how these engineers got such good ESD ratings. Two of the best three were digital ICs, so all of our analog engineers were encouraged to learn the secrets of that one "ro-

bust" analog circuit that would pass not just 2 kV, or 4, but 6 kV of ESD. Hey, that's really a very good, strong ESD circuit. How did those designers do it? With a special ESD protection algorithm and special clamp diodes? Let's find out what this circuit looks like!

First, what's the name of this IC?

It's an LM340. Okay—do you guys recognize the part number? The LM340 is a 1-A, 3-terminal regulator, and for all intents and practical purposes, it passes a high ESD test by the *brilliant strategy* of having a 1-A power transistor on every pin. So, if we want to design a quad op amp with really good ESD ratings, obviously all we have to do is add twelve 1-A power transistors, one on each input and output pin. Of course, the die size of an LM324 would increase by a factor of 9, and the input capacitance and leakage would be completely unacceptable. Everybody would love the ESD ratings, but nobody could afford the circuit. In fact, we could not even fit it into a 14-pin DIP package. But if we're to learn from the LM340's designer (George Cleveland) and if we applied his teaching so as to achieve the *highest* ESD ratings, then that's the circuit we would design. Ahem. Ahem! Needless to say, we came up with some slightly more *compact* and *cost-effective* circuits to protect our new ICs.

Similarly, one of our customers wanted to see our report on ESD on a

new IC. It passed the required 2-kV test on 37 of the 40 pins. So the customer proposed that we must add a new ESD cell to *all* of the pins to improve the ESD ratings. After all, the customer wanted the *highest possible* ratings. But we observed that if we add the ESD cell to every pin, the die size would increase by 12%, the yield would drop, and the cost per IC would increase by several percentage points. If they wanted to have the highest ESD tolerance, did they want to pay for it? No. So, after much debate, they decided to accept the part with the ESD cell added to only those pins that needed it. *That* was what they were willing to pay for.

Now, most people have an adequate awareness of ESD problems. If you walk across a carpet on a dry day in winter and bring your finger near a circuit, it's real easy to generate a spark that might damage the circuit. The industry has a reasonably accurate model of this abuse: Charge up a 100-pF capacitor to a couple thousand volts, and then discharge the capacitor through a 1500-Ω resistor into a pin or node of a circuit. This impedance is commonly known as the "human body model." This is considered a fairly minimal ESD test, yet it puts a surge of 1.3 A through most paths for a couple hundred nanoseconds. That's pretty scary for a little IC where the data sheet tells you to never exceed 10 mA into any pin. A lot of good ICs will

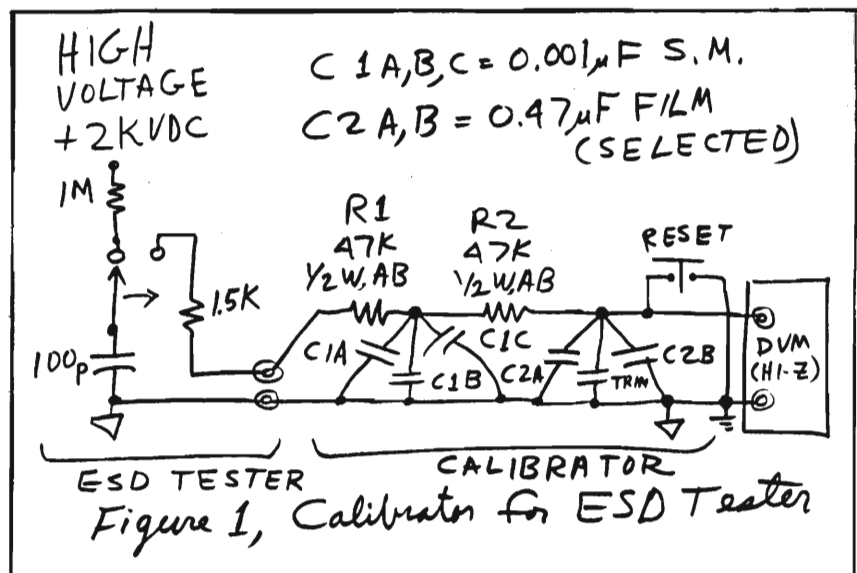



# PEASE PORRIDGE

pass this test, and even if the voltage is doubled, (note also that the energy will quadruple) some ICs survive just fine. But a lot of them do not. So if you are building a million radios, there's a definite incentive to buy semiconductors that are pretty reliable. Minor accidents that cause an occasional zap

to a circuit may occur even though every assembler or worker on the production line is carefully grounded through a 1-M $\Omega$  wrist strap.

Now, when is a piece of "grounded" test equipment not "grounded?" When you can measure 500 V on some parts of the equipment, for example.

(Once I saw a lab where two workbenches, about 7 feet apart, had 2500-V ac between them...a long time ago.) When is a 1-M $\Omega$  floor not 1 M $\Omega$ ? When the janitor decided to wax it... What is the main difference between a conveyor belt on a production line, and one on a Van de Graaff generator? Answer, one is vertical and the other is horizontal. But both can generate lots of volts.

So, to make sure our ICs are reliable, we have bought various ESD testers, and we perform all sorts of zap tests on our new *and* old ICs. I once wanted to add a Zener diode to a pin of one of my ICs to prevent damage to a differential pair. One of the senior engineers said, when he saw my drawing, "You'll get in trouble when that Zener gets zapped by ESD." But after a lot of thought, I left it in anyway, and in actuality, we have never had any customer complaints about that terminal. I checked recently, and that IC has passed 2000 V on every pin—even the pin with the Zener. So when an expert tells you, "You have to do *this*, and you can't do *that*," just remember that even experts can be wrong....

One major purchaser of ICs came out with a drawing for the "Machine Model" of ESD testing. This represents what happens when a device is held in a large metal arm, inadvertently charged to a high voltage, and then it touches a grounded piece of metal. In this test, a 100-pF capacitor is discharged through 0  $\Omega$  (not 1500  $\Omega$ ) into a device's pin. Well, if you could really discharge a capacitor through 0  $\Omega$ , the current would be infinite, right? Ah, but there's always some inductance. And if you stand at the DUT and look back at the capacitance, the wiring has a certain characteristic impedance or resistance—perhaps 50  $\Omega$ , perhaps 90  $\Omega$ . That helps explain why you can't have an infinite current, and you can't have 0  $\Omega$ . After several suppliers complained to the Customer that it wasn't realistic to have a source impedance of 0  $\Omega$  for that test, the Customer changed the control drawing to say "0  $\Omega$   $\pm$ 5%." Still, despite cases as silly as that, it's important when you do your ESD testing to keep your wires fairly short and compact,



## Isolated 4-20mA Two-Wire Transmitter Conditions RTD Signals

IXR100 is a new, self-powered, isolated 2-wire transmitter. It excites and linearizes signals from RTDs and thermocouples, while supplying signal and power on a single 4-20mA wire-pair by modulating power supply current with the isolated signal source. This versatile device includes: matched 400 $\mu$ A current sources for sensor excitation; an internal supply voltage regulator; an input amplifier and V/I converter; RTD correction circuitry providing up to 50 times better linearity than basic RTDs; and a DC/DC converter.

### Industrial Strength

IXR100 breaks ground-loops and provides up to 1500Vrms galvanic isolation protection for industrial signals in noisy, electronically hazardous environments. Zero and span drift are very low, and the device performs at full specifications with supply voltages from 36V to as low as 11.6V. IXR100 is small enough—1.6"x0.9"x0.9"—to use in thermowells, and is an excellent choice for a broad range of factory/process data acquisition and control applications.

### Key IXR100 Specifications

- Isolation voltage .....1500Vrms
- Output current.....4-20mA
- Nonlinearity (Pt100,1000 $^{\circ}$ C span) .....0.1% of FSR
- Temp range .....-20/+70 $^{\circ}$ C

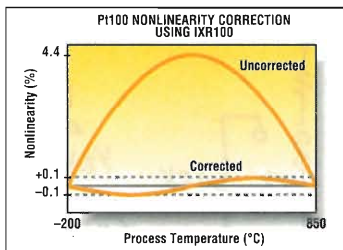

Need more information? Just FAX: 1-602-741-3895. Or, contact your local sales representative.



Austria (43) 222 62 63 71, France (33) 1 395 43558, Germany (49) 711 77040, Italy (39) 2 580 10504, Japan (81) 33 586 8141, Netherlands (31) 03465 50204, Switzerland (41) 1 7240928, United Kingdom (44) 923 233837.

CIRCLE180 FOR U.S. RESPONSE  
CIRCLE 181 FOR RESPONSE OUTSIDE THE U.S.

## PEASE PORRIDGE

to keep the inductance low. This gives a fair rise time for the current pulse. No point in trying to fool everybody, including yourself, with a wiring path that causes slow rise times.

National bought a \$200,000 Zap-Master ESD tester from Keytek\*—there are only two in the world (AT&T has the other one). When we test parts and get results, they don't agree with AT&T's results. That's because AT&T chose to use their machine to apply pulses, both + and -, into a grounded part. NSC chose to apply a high voltage bias to the DUT and discharge the part into ground, which is a more severe test. It just goes to show that there are many disagreements on what is the "right" way to do an ESD test. There isn't necessarily any fully-agreed-upon procedure, no "industry standard," no repeatable test, no consistent results. However, we've been able to use some of these tests to design ESD structures that not only meet good ESD ratings, but are also predictable by Spice analysis. So if Spice can teach us what is *good*, maybe it can teach us what is *better*. If we are able to come out with consistently improved stress ratings in a year or two, I will be impressed, and amazed!!

What happens when one IC of a lot of 30 fails at 1300 V, and the other 29 survive past 2300 V? That's very frustrating, and it may indicate a minor manufacturing flaw (a pin-hole oxide flaw?) that happens at a low occurrence rate. Sometimes you get 11 out of 30 failing at 1300 V and 19 good at 2300 V. Very confusing. One guy pointed out that this can happen when some of the gates and flip-flops start up in one output state, which is more resistant to stress. If the gates bias up to the opposite state on another pulse, the part might fail. So, sometimes you can test a part five times at 1600 V and it's okay, yet the next test at 1200 V causes a failure. Does it sound to you like there's something nonlinear going on?!!! Well, if you think it's fun to analyze circuits in Spice at audio frequencies, just imagine how much fun it is to analyze the transient response of a little piece of an IC, where the current builds up to a couple amperes in 10 ns! Some engineers, though, seem to be

making some progress in this area.

But what if you test a batch of ICs and they're all passing 2400 V just fine, yet you take them over to another tester and they start failing at 1400 V? Does that mean that the first half of the batch of ICs is much stronger than the second half? No, that's not the case. That dichotomy usually occurs because the *second* ESD tester—the one that belongs to the Reliability Group—is well calibrated. The problem arises because the *first* tester, which is kept around the development engineering lab, has gone out of calibration and is putting out MUCH too low a pulse. Thus, the parts are made to look good due to false testing. Let me assure you, I've heard of this happening several times. In fact, a guy told me yesterday that it happened *again* to his newest IC. His initial test led him to think it was okay, but the accurate tester told him that it really was not. We were fooled, but not for long.

I told him to go out and make up a calibrator network to add onto the ESD tester. The network is really very simple, as shown in Figure 1. The exact R and C values aren't important, but you really do want to understand the philosophy. Every time you "hit the button" to discharge the capacitor, a certain quantity of charge ( $Q = C \times V$ ) is dumped down into the big capacitors. If the total capacitance is about 1  $\mu\text{F}$ , then 200-mV output change corresponds to 2 kV of ESD pulse. So the main thing is to have C2 at about 1.0  $\mu\text{F}$ . I like to make C2 out of a couple selected 0.47  $\mu\text{F}$  caps. Why selected? Well, if the first two capacitors I grabbed were 0.52  $\mu\text{F}$ , the calibration factor would be off, and it would be hard to trim to get the right scale factor. So the selection process is to select 2 or 3 capacitors that make up 0.95 to 0.99  $\mu\text{F}$  total. Then add on some trim caps to get the total near 0.997  $\mu\text{F}$ . That covers the calibration.

Why bother to have C1? Well, if you force a 2-A pulse into a wound film capacitor, the inductance of the windings might cause a voltage overstress of the film. It's better to have C1 = 3000 pF so that the pulse of current fed to C2 doesn't have any extreme values. The other good thing about C1

is making it out of three 1000-pF capacitors, perhaps NP0 ceramic or silvered mica, that are standing up like a tripod. Then, if you make C2 out of two film capacitors that act like a bipod, the whole scheme stands up off a little piece of copper-clad fairly strong and rigid, not wobbly as it would be if you just used one capacitor for C1 and one for C2.

What about R1? Well, I would use 47k or 47  $\Omega$ , carbon composition, Allen Bradley 1/2 watt. The resistance value is not a big deal, but you really should use a carbon-composition type that can handle an ampere or two without breaking down (if you used a film resistor, the high di/dt of the pulse is likely to cause a momentary breakdown between adjacent spirals). A good value for R2 would be 47k or 100k, also AB 1/2-watt carbon composition. Because this resistor is unlikely to see more than 300 V, it's not so critical, but I like to use carbon comp to remind me that film resistors aren't always preferable.

If you have a voltmeter with an  $R_{in}$  of 10 M $\Omega$ , that's not quite as good as 1000 M $\Omega$ . But you will be able to see an indication that a 2-kV pulse does give something like a 200-mV jump. Heck, 180 is substantially the same as 200. But an indication of 160 or 130 mV would be wrong. This isn't necessarily a precision calibrator, but it's a pretty good lie detector. After all, it works on the conservation of charge (not the conservation of energy). The note we are putting on our ESD testers and calibrators says:

1. Do not remove this calibrator under pain of death.
2. Many of these ESD testers have been known to fail in a mode with an actual pulse output amplitude of 1/2 to 1/4 of the indicated voltage.
3. Therefore, every day you use the tester, check its calibration. Set the pulse level to 2000 V and watch the output jump 200 mV for each pulse. If 4000 V, expect to see 400 mV. You can short the 1  $\mu\text{F}$  to ground to reset it, or, just put your fingers across it.\*\*
4. Calibration procedure is available from Cal Lab, Paragraph 93-14. (Measure total capacitance = 1.0  $\mu\text{F}$   $\pm 1\%$  when R2 is shorted out.)"



## PEASE PORRIDGE

Anyhow, for the last 6 months I knew that I would eventually write a column on ESD, but I didn't have any strong motivation or impetus to do it. Nothing really important to say. But as soon as I recognized the importance of having a simple calibrator to help you catch your ESD tester as soon as it goofs up, that drove me to draft up and finish this column, pronto—and here you are.

All for now. / Comments invited!  
RAP / Robert A. Pease / Engineer

Address:  
Mail Stop D2597A (note change!)  
National Semiconductor  
P.O. Box 58090  
Santa Clara, CA 95052-8090

\*Keytek Corp, 260 Fordham Rd., Wilmington MA 01887.

\*\* One of our legally oriented guys suggested a disclaimer: Whenever he

hears the word "kilovolt," he doesn't want to go around touching anything, even if the DVM says 0.42 V... So, okay, go ahead and rig a push-button switch to short out the 1  $\mu$ F, if you want to. BUT, a 4-kV pulse from a standard human-body-model tester doesn't BITE or TICKLE much at all. It sure doesn't hurt most people....

### BOB'S MAILBOX

*Dear Bob:*

Regarding your notes on double-clutching in the August issue—as a veteran of driving our original family VW (a used 1951 model that my father acquired in 1953) I had to become expert at this, as the transmission was entirely non-synchro (presumably matching the mechanical brakes in mechanical simplicity). Upshifting (1-2, etc.) did not require double-clutching, but merely a short pause while

the gears spin down to the appropriate speed for the next ratio.

...Of course, you did indeed have to double-clutch any time you needed to down-shift. The "blip" method was elegant and demonstrated considerable skill if executed properly. I had better luck, especially for shifts into first, if I released the clutch in neutral, accelerated the engine to the correct RPM for my speed (or slightly higher as you say), and then very quickly declutched and pulled it into gear. Easier to judge the RPM than a somewhat random blip of the throttle, and the engine speed would be correct for smooth engagement...

**PATRICK H. QUILTER**

*Costa Mesa, Calif.*

*Recently, my wet shoelaces flapping my leg twice every time I shifted, convinced me I really do double-clutch all the time. But I'm not sure I could handle a full-time crash-box.*  
—RAP

# RUGGED UPS SYSTEMS

## For Severe Environments

- On-Line System Delivers Seamless Back-Up Power 1k VA to 10k VA
- ZONE 2 Compatible Controls & Alarms
- Precision Regulated Sinewave Output
- Power Corrected Universal Input
- Reliable MIL-SPEC Design

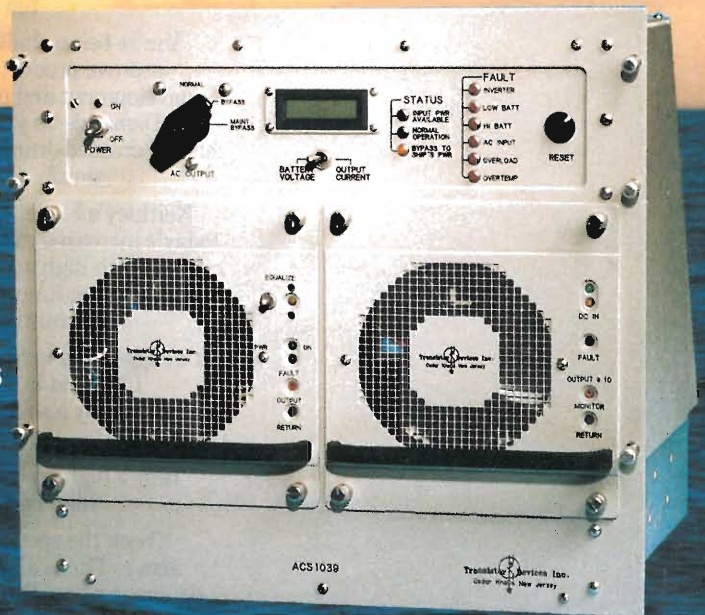

Transistor  Devices Inc.

CIRCLE 172 FOR U.S. RESPONSE

FAX (201) 361-7665 FOR RESPONSE OUTSIDE THE U.S.

85 HORSEHILL ROAD, CEDAR KNOLLS, N.J. 07927 • (201) 267-1900 • FAX: (201) 267-2047

## PEASE PORRIDGE



# BOB'S MAILBOX

### Dear Bob:

I was just finishing up a report on fuzzy logic when a co-worker handed me a copy of your article "What's All This Fuzzy Logic Stuff, Anyhow?" in the May 13 issue. In short, I agree. It is extremely refreshing to hear a voice of reason in this age of emperor's new clothing.

I have included the first version of said report. It covers the development of a fuzzy-logic controller (and that of a corresponding classical controller) for the balancing of an inverted pendulum attached to the end of a robotic arm. The effort was requested by NASA in order to aid in the evaluation of fuzzy-logic-control-system design techniques. I hope you can find time to read it (at least the results and conclusions).

In the article, the use of the term "deterministic" to describe conventional controllers is unfortunate because it implies that fuzzy-logic controllers are not deterministic. In fact, fuzzy-logic controllers are completely deterministic. More specifically, the end result of a fuzzy-logic control system (assuming no add-ons or hybrids) is simply a function. That is to say, it generates a unique value of any output variable (e.g. current to a motor) for every unique set of values on the input variables (e.g. angular position and rate of the motor shaft as feedback variables).

Fuzzy logic is simply a design technique that is based on the use of intuition in designing a control function—a method to convert fuzzy human statements about how to control something into a completely deterministic relationship between controller inputs and outputs. Now, any control function can be developed in many different ways (a linear function can even be easily modified to be nonlinear if desired, what with today's modern computers!), and the performance is only dependent on the function, not the technique used to develop it. Thus the real issue is whether one technique or

another is more helpful to the designer in developing a function. What technique(s) is used is primarily a matter of taste for the designer. Statements such as "fuzzy-logic controllers perform better than conventional controllers" are nonsense.

Finally, let me say that the idea of using fuzzy logic to convert human intuitive statements into a working function initially caught my fancy (for various reasons). However, this is far more complicated than it sounds. In my development of two very different control systems (one being a highly nonlinear "phase plane" controller for thruster-actuated space vehicles) with fuzzy logic and other control techniques, fuzzy logic proved to be a very poor technique. It took me *far* longer to develop fuzzy-logic systems, that achieved the same performance (and almost identical resulting functions) as with the other techniques that I used. The designer must mentally juggle many numbers and rules in specifying the fuzzy-logic system, and understanding the relationships between these and the observed system behaviors can be very frustrating indeed.

**LAWRENCE E. MERKEL**

**Lockheed-ESC**

**Houston, Texas**

*Isn't it funny—the F.L. approach is always very easy for F.L. guys who don't know how to do it any other way! I suspect that making F.L. work well isn't as simple as they say. Thanks for your observations.—RAP*

### Dear Bob:

I recently read an article that talked about the lack of "feel" for engineering in the current crop of engineering students. It disturbed me that this condition should exist. The article goes on to lament that many of the students had never dissected nor constructed anything before graduation, and that special courses were being designed for this purpose. What in the world are they doing in the field

if they have gotten as far as college and have not dissected anything or constructed anything?

When I was nine years old, I constructed my "soap box" racer out of an old crate, a 2-by-4, and a roller skate that I had taken apart. I even had a headlight that I had made from the lens/bulb assembly of an old flashlight and a large type "A" cell. I did all this without any input from adults. I copied the design from "soap box" racers that I had seen kids use in Brooklyn, N.Y.

In 1955, when I was in the 8th grade, I got an "Honorable Mention" for my science fair exhibit, "The Transistor, an Electronic Marvel." I constructed a two-transistor audio amplifier (using Raytheon CK722s) and explained its operation and the operation of the transistor. I suppose it really was an engineering project and not scientific research. I did it on my own initiative and without any adult guidance. Maybe I would have done better if I had some guidance, but maybe it would not have served me well in life.

As a fifteen year old, I built a short-wave converter for my AM radio. I got the circuit schematic from an amateur radio handbook. I purchased the components, did the sheet metal work, and assembled it by myself. There was no adult involvement here either. I still have it and it still works.

I don't know if you are familiar with the famous "Canal Street" in New York City. At least it was famous in the '50s for its surplus electronics outlets. I used to make many pilgrimages there in my youth. On one trip, a friend and I carried home a 400-Hz generator "safari style," i.e., slung from a pole we carried between us on our shoulders. He needed it for his surplus ham equipment. We carried it this way on the Staten Island Ferry and then onto the New Jersey Central Railroad for the ride home. I had picked up a bargain mercury thermometer, which promptly got broken



# PEASE PORRIDGE

when I got caught in a swinging door at the ferry terminal. Ouch, a whole buck down the tubes...

The examples I could cite are almost endless. You may say that my experience was unique. Well, at the time it wasn't. Most of the people I knew in the College of Engineering at

Rutgers University were either hams or hobbyists or experimenters. I, and others in my lab group, could not believe it when one of our lab partners asked us what a resistor looked like. He had done all the theoretical calculations in the various classes, but had never actually handled any of the

parts. He was unique, though, and caught on quickly. He later got his PhD in Physics and was doing heat balance work on communications satellites.

You may say that kids today don't do that kind of thing anymore. Well, you would be wrong. My son, who's a junior in high school, worked on robotics projects at home during the summer. He has an old VIC-20 computer and a Fischer-Techniks kit. He is building working models of machine tools and other gadgets. He has assembled a siren, an AM radio, a burglar alarm, model rockets, and other goodies from kits. He has taken "junk" electronics and made them functional. He has dissected countless mechanical gadgets. He works on his bicycle by himself. He has the "soul" of an engineer. I think it comes from within. I don't think you can train it into someone.

So, tell me what is really wrong with today's crop of engineers? Is it the age of instant gratification, where building a kit model airplane takes too long? Is it the lack of role models? After all, anyone today who likes math and science is considered a nerd. In my day, I was classified as an "egg-head." But I got along with everyone: jocks, hoods, and the "in" crowd. I did not consider it a "put down." How would I fare today?

Finally, I am appalled that the article states, "Employers visiting the campus stress that it is more their communication skills that help students advance than engineering know how." I suppose you can design junk, but as long as you present it well, it's OK. I wonder if you value communications skills over engineering skills?

Why am I rambling on like this? Well, I feel that you are a kindred soul. You, and others like you, seem to be a breed that is slowly dying out. Any comments?

**ALEXANDER F. JASZEK**  
Needham, Mass.

*Well, since most electronic stuff is "non-repairable," and there are no more Heathkits, it's hard to get kids interested in electronics—unless you count computers. There are still some bright kids coming along. Maybe we don't need more engineers, but we could sure use some smart ones!—RAP*



## Universal Measurement Channel Fills the Industrial Automation "Gap"

ISC300 is an isolated measurement channel with open circuit sensor detection for use with many sensor types such as bridges, RTDs, and thermocouple temperature sensors. It's a complete device, including a low drift voltage reference, differential high impedance input; precision matched current sources; digitally selectable gain; fault detect bias resistors; isolated DC/DC converter; synchronizable internal oscillator; and two isolated power supplies available for external circuitry. ISC300 contains all the functions needed to fill the "gap" between sensors and A/D converters for most industrial/process data acquisition and control applications.

### Simple, Plug-In Solutions

ISC300 can be used with a wide variety of sensors including pressure, humidity, and flow sensors to provide ground loop isolation. It's an easy to use, easy to design-in solution in a single SIP package for process control systems. For RTD, thermocouple, instrument bridge,  $\pm 100\text{mV}$ ,  $\pm 10\text{V}$  and 4 to 20mA inputs, the ISC300 is almost a "plug-in and go" solution with added isolation, upscale and downscale indication, and error compensation capability. A fully-assembled demo board is available to facilitate testing and evaluation.

### Key ISC300 Specifications

- Isolation voltage .....500Vrms
- Linearity .....0.0025% of FSR
- Temp range .....0°/+70°C

Need more information? Just FAX: **1-602-741-3895**. Or, contact your local sales representative.



Austria (43) 222 62 63 71, France (33) 1 395 43558, Germany (49) 711 77040, Italy (39) 2 580 10504, Japan (81) 33 586 8141, Netherlands (31) 03465 50204, Switzerland (41) 1 7240928, United Kingdom (44) 923 233837.

CIRCLE 212 FOR U.S. RESPONSE

CIRCLE 213 FOR RESPONSE OUTSIDE THE U.S.

# WHAT'S ALL THIS FUZZY LOGIC STUFF, ANYHOW (PART II)?

If you can think of an unlikely person to study Fuzzy Logic, it's RAP. While it's a dirty, nasty job, somebody must do it, and I've had lots of encouragement from all you readers since I put out my first column on the subject.<sup>1</sup> Note, some people have characterized me as being a detractor of Fuzzy Logic (F.L.), but I think I have done more good for the field of F.L. than lots of other guys all put together. I think it's to nobody's benefit to have people bragging about advantages that are unreal.

I believe people who are making responsible, intelligent claims for F.L.



**BOB PEASE**  
OBTAINED A BSEE FROM MIT IN 1961 AND IS STAFF SCIENTIST AT NATIONAL SEMICONDUCTOR CORP., SANTA CLARA, CALIF.

will be glad to have me on their side, to cut down on irresponsible, unfair, preposterous claims. I consider myself, rather, a skeptic—and here is a laundry list of ideas I have figured out or discovered so far:

1. Nobody has yet submitted to me any realistic task or control loop that they did with Fuzzy Logic which I could duplicate.<sup>2</sup> Isn't it strange that some Fuzzy Logic promoters want to quiet down Pease, but none of them has brought me a nice simple example to show how F.L. really is better than conventional systems (and, after we turn on the lights, we hear them scuttling under the cabinets). I didn't expect to get many, but zero is indeed a very inter-

esting number. However, as one person pointed out, the F.L. experts who really are good are too busy to fool around with demonstrations, since they have lots of work to do—that's a fair explanation.

2. Almost everybody agrees that the examples I gave of outrageous F.L. claims were indeed pretty incredible, and that some F.L. promoters do exaggerate a lot. Several people sent in additional examples of Fuzzy Logic hype, such as pumps that allegedly come up to speed 2 times faster than with a "conventional" controller, and fuzzy motor controllers with miraculous "advantages"....

3. I have seen several readers give the same opinion that F.L. will be a lot more useful and valuable than its detractors predict, but a lot less useful and valuable than its promoters have said. Some of the claims, for example, that 50% of all microprocessors will be used for F.L. by 1996 seem a bit far-out.

4. Some promoters of F.L. are quite young, and when they promote F.L. as superior to other kinds of controllers, they show fantastic advantages—not out of malice, but just because they're not really familiar with the capabilities of other techniques. So they set up a straw man, which they then proceed to knock over easily. They do this because they don't know any better. Those of us who know better have an obligation to explain this to them.

5. Some F.L. guys aren't very good at explaining. Certain people think this may arise from their experiences in applying for research grants: If they clarify everything, and make it look too clear and easy, how can they apply for another grant to explain yet more? Even allowing for this, they still

aren't very good at explaining things. They love to use lots of jargon. They speak in terms that are suitable for "preaching to the converted," but don't make clear explanations to the rest of us. Then they bleat that the rest of the world is closed-minded and prejudiced against them. I wonder why that is....

6. For example, some of them like to talk about the ability of their math to handle "probability." When you check it out, you find that they're talking about *proportionality*—the analog parameters. But because many of their old mathematical tools are borrowed from the probability experts, they persist in using that phrase. It bugs the hell out of me!!

7. Many F.L. guys love to make rash, outrageous philosophical claims: "With Fuzzy Logic controllers, you don't need any models." "With F.L., you never have to worry about the Nyquist sample rate." "You do not need to know the characteristics of a plant to design a controller for it." "The major advantage in the use of a fuzzy loop is that it reacts much faster to a process disturbance (or to overshoot and undershoot) than does a standard PID loop."<sup>3</sup> After much debate and criticism from conventional control experts, they may concede their claims aren't entirely true, but only after they have succeeded in getting everybody mad at them.

8. F.L. is claimed to make a good servo for some kinds of systems where conventional controllers don't work well. WELL, let's assume that in some cases it's true. Then how do you prove that such an F.L. system has good dynamic stability in all cases? For conventional controllers, there are methods to prove that a controller has a good safety margin of dynamic stability. How can you demonstrate and prove adequate safety margins/safety factors for F.L. systems? Remember—F.L. claims advantages because it can accommodate system nonlinearity by incorporating appropriate nonlinearity in the controller. How do you prove that this is safe? How much proof is necessary? That sounds like a real problem to me. If your new F.L. washing machine

blows up, how can the manufacturer prove to the jury that he used the best available tests to ensure customer safety? As with any nonlinear controller system, extensive testing is needed to prove that no regions of instability will jeopardize proper system operation.

9. Some people pointed out that a Fuzzy Logic system is a kind of Expert System—a form of Artificial Intelligence. Now, the F.L. people may not like to talk about this because of the disappointments with Expert Systems in the past. But, are these not some of the same people who worked with Expert Systems and Artificial Intelligence in the past?? You tell me. Still, despite old disappointments, this seems to be a place where the Expert System, under the name of Fuzzy Logic, finally begins to fulfill its promise. MEANWHILE, some Artificial Intelligence experts are the most adamant detractors of F.L., because they have their math, and do not like to see F.L. people using “linguistic variables.” Personally, if I hear “If the input is *small*, the output is *little*,” one more time, I will vomit.

10. Let's assume that F.L. really can help make vacuum cleaners and washing machines work better. If that's the case, they do so because of the SENSORS. Which is more important, better sensors or the F.L.?? Maybe those smart, aggressive, and problem-solving F.L. guys will use the sensors very thoughtfully. Which is the chicken, which the egg? I can't say.

11. Fuzzy Logic doesn't really generate a control law. It maps an existing control law from one set of rules into a logic set.<sup>4</sup> If the rules permit this to be done efficiently, it may be able to accomplish the computing function just by remapping. That's a well-known way to get your computation done quickly. But the programmer or rule-maker has to provide the mapping functions—the rules. However, writing those rules isn't a trivial exercise. Even if you want to let Neural Networks write the rules for you, as with NeuFuz4,<sup>5</sup> that can be quite a piece of work.

12. F.L. guys universally ignore the role of their input sensors, their analog-to-digital converters, and the format of the (digital) interface to their

Fuzzy Processors. I've heard people say that in some cases, F.L. works just fine with a single input bit stream. In other cases, the controller obviously requires an 8-bit, 10-bit, 12-bit, or higher-resolution parallel data bus. But (just about) every Fuzzy Experimenter makes ZERO mention of the input data. One person admitted about F.L. designers: “Of course they need good input data, and they just *assume* that the data will be made available to them in a suitable format.”

...Well now, what format is that? It certainly isn't the same for every case, and, therefore, it should certainly be discussed. Every time I've looked at an “example” of a real Fuzzy Logic system or controller, the data inputs were left completely unmentioned. This frustrates the hell out of me because I know that in the real world, in a real system, this is quite important. Caution—don't be fooled into thinking, as one of my friends did, that a F.L. system only needs a 3-bit ADC at its input, because there are only 3 or 4 “rules.” These few rules will take in and process the 8 or more bits of data (1 part in 256 resolution), which they then map into an output with full 8-bit (or more) resolution.

Also, don't think that the F.L. process is fuzzy or imprecise, or isn't “deterministic”. I have been informed to point out that when the input moves a small amount, the output will move an appropriate amount, with no real uncertainty or doubt. A F.L. controller is, normally, just as “deterministic” as a conventional controller, whether analog or digital. It just uses different internal processes.

The “fuzziness” in F.L. just refers to the way that an object is in a set. In classical set theory, an object is either in a set or it is not. There's no “in-between,” no grading. In the real world, of course, objects can be in a set “partially.” F.L. extends classical set theory by assigning degrees of membership (typically, fractional amounts) to objects in such a way as to not conflict with classical set theory.<sup>6</sup>

Thus, F.L. can serve as a generalization and as an extension of existing set theory to help solve real-world problems in cases where traditional

methods fail, or where nonlinearities cause poor results in price or performance. Of course, many of us engineers use analog signals to represent that proportionality.

13. Note that in most real systems, whether F.L. or conventional, it's important for the system to be given good information, with good resolution and good accuracy. If adequate information isn't made available, it's unclear how either one will do a good job. Specifically, when F.L. guys say that “You never have to worry about the Nyquist sample rate,” that is true only if you have a big safety margin. If your F.L. system's sample rate is too low, and your system works badly, then *of course* you have to worry about it, just as everybody else does.<sup>7</sup>

14. In a conventional digital or analog controller, it is customary to provide a parameter, such as distance or rotation, to the controller. The controller then computes a derivative or difference signal,  $dx/dt$ , or  $\Delta x/\Delta t$ . But in a F.L. system, you have to *provide* the  $x$  data and then a derivative,  $dx/dt$ . Apparently F.L. falls short when it comes to timing or counting, so the F.L. controller can't compute the derivative function—you have to provide it that. Therefore it's *not* quite true that an F.L. system needs the same information as a conventional controller—sometimes it needs *more* information.

15. LIKEWISE, Fuzzy guys uniformly ignore the output format of their systems. Is it serial or parallel? They're always too shy to mention this. I did hear that for the Inverted Pendulum experiment, the F.L. approach is so greatly superior to conventional controllers that it puts out just a serial pulse train (the signal is the duty cycle) which controls the loop without any trouble. Yet in other cases, it's obvious that the output must comprise parallel bits to a conventional DAC. But they never make any reference to this, either. How many bits, 8, 12, or 16? Nobody talks about this; it's “academic” and is left as an exercise to the reader.

16. Not only do the F.L. guys never talk about their input interface or their outputs, they also avoid talking about the actual computer or micro-



# PEASE PORRIDGE

processor they use. They rarely mention the number of bits, or the clock rate, or the software. They always try to keep things "academic"—and they don't tell you what they really did.

NOW, let's talk about cases where F.L. may have advantages:

17. Fuzzy Logic is generally admitted—even by RAP—to have real advantages where the system is non-linear. One simple example, again, is the Inverted Pendulum, where the base of a stick on a pivot is moved along a track by a little motor. The angular acceleration of the pendulum is NOT a linear function of its angle away from vertical, but a sort of third-power law. If you try to approximate this with a linear function, it's hard to get the gain right. It's either too low at the ends or too high in the middle. Or else you have to compute the function precisely, which takes a LOT of computation. But with F.L., you can get the gain approximately right with just a few segments of F.L. coding—perhaps just 5 rules. These rules now are so simple, that the F.L. computing processors can compute this with good speed, and a cheap computer, faster and cheaper than a conventional computer can do when it computes EXACTLY the equations of motion for that Inverted Pendulum. Consequently, if the computer can go faster, it may be able to do a superior job of controlling, because although its math is crude, it's plenty accurate enough, and it's *fast*. NOW, when you compound the problem by stacking *two* inverted pendulums on top of each other, F.L. can still do it easily. For the *triple* inverted pendulum, F.L. can still do it, whereas conventional controllers apparently can't do all of the complicated math fast enough. *Maybe* if you made some simplifying assumptions, some approximations, the conventional controller could then go fast enough, but this is generally ignored. F.L. can make certain assumptions, approximations, and simplifications, but other controllers aren't supposed to be able to do this.

18. F.L. is supposed to have real advantages where an approximate system solution is adequate. For example, I read a statement by a F.L. promoter<sup>8</sup> that said if you want a com-

puter to park your car for you, you should exploit imprecision. If you don't need the car at exactly 6.00 ± 0.02 inches from the curb, but something like 6 ± 2 inches, then F.L. may be able to do a superior job, especially since you can use a cheap computer. When I read this, I was struck by its wisdom. But who would dare to admit that F.L. is not only not always better, but sometimes, *inferior* in accuracy, yet it's still plenty good enough? I looked, and it was Lotfi Zadeh himself, the creator of Fuzzy Logic. He was wise enough to say that, and I'm delighted to say I agree that when a solution is good enough, don't worry about perfection. I'm absolutely in favor of pragmatism, and of good-enough engineering. Perfectionism is the bane of cost-effective engineering. Anybody who knows when to do a good-enough job and *stop* is a friend of mine.

19. Let me insert an *esaeP's* fable here: One time I was bicycling down Massachusetts Avenue in Cambridge, Mass. on a quiet Sunday morning, and a dog started chasing me. Because I was on a downgrade I accelerated well, and the dog fell a few yards behind me. He could not gain on me, and I was going fast enough, so I did not bother to pull further away from him. At a split in the road, I continued on down Mass Ave. The dog veered off onto Mt. Auburn Street, barking all the way, as if to say that he was not really chasing me at all, so he did not care if he had not caught me.

WELL, when I make a few convincing arguments to rebut the F.L. claim that "F.L. is always better", the F.L. experts often veer away, saying, "Even if it is not always more precise, it is less expensive...." NOW, F.L. is *alleged* to be a less expensive way to run a controller. In some cases, it may be able to use a cheap computer. It may use fewer lines of code or a smaller ROM. The F.L. guys love to claim this. But I don't automatically trust them when they say "it's cheaper." After all, what would you expect them to say?? I am still skeptical about these guys. Other experienced engineers find that for some cases, *conventional* controllers can be more compact, cheaper, and easier to program than F.L. So, if in a given

system the F.L. experts claim that F.L. is cheaper, you had better check their data. Make your own cost comparisons. Don't let them just set up straw comparisons.

Stay tuned for more Fuzzy Logic stuff in the next issue...

All for now. / Comments invited!  
RAP / Robert A. Pease / Engineer

Address:  
Mail Stop D2597A (note change!)  
National Semiconductor  
P.O. Box 58090  
Santa Clara, CA 95052-8090

## References:

1. "What's All This Fuzzy Logic Stuff, Anyhow?," R. A. Pease, *Electronic Design*, May 13, 1993, pp. 77-79.
2. One reader sent a report on a design involving a focusing system for a laser's lenses, but I couldn't very well duplicate that. Another person promised to send me more info about a motor speed controller, but never sent anything. One writer said that "all of the arguments of the above writer are not right," but gave no specific example of anything in my writing he thought was wrong....
3. "Fuzzy Logic: A Clear Choice For Temperature Control", Haubold vom Berg, *Instruments and Control Systems*, June 1993, pp. 39-41.
4. Private correspondence with Daniel Abramovitch, Hewlett-Packard Labs, Palo Alto, Calif. June 30, 1993.
5. NeuFuz4 from NSC, combining Neural Networks and Fuzzy Logic. The Neural Network part can learn from recorded data, then generate fuzzy rules and membership functions. Thus, it can learn the best way to control the system. Call (800) 272-9959 for details.
6. "Fuzzy Models - What Are They, And Why?" J. Bezdek, *IEEE Transactions on Fuzzy Systems*. Feb. 1993, pp. 1-6. A good introduction to Fuzzy Sets and concepts.
7. Private correspondence with Daniel Abramovitch, Hewlett-Packard Labs, Palo Alto, CA. June 30, 1993.
8. "On The Fuzzy Edge Of Technology", Tom Williams (quote of Lotfi Zadeh), *Computer Design*, April 1993, p. 14.

# WHAT'S ALL THIS FUZZY LOGIC STUFF, ANYHOW (PART III)?

**L**et's jump right in and continue on with the Fuzzy Logic laundry list I started in the last issue.

20. F.L. is alleged to be "faster and easier to develop." That's what the F.L. guys like to claim. Again, I still don't really trust them. What would you expect them to say? Other engineers argue that the claimed ease and speed are not always there.

I am not in any position to prove this one way or the other, but you had best be on your toes, and insist on satisfactory comparisons. In other words, don't permit any straw men to be perpetuated. Or perpetrated.



**BOB PEASE**  
OBTAINED A BSEE FROM MIT IN 1961 AND IS STAFF SCIENTIST AT NATIONAL SEMICONDUCTOR CORP., SANTA CLARA, CALIF.

Besides, even the proponents of F.L. admit that sometimes, tuning a F.L. system can take "hours or days of computer time..."<sup>9</sup> In a similar vein, Haubold vom Berg<sup>10</sup> cautions, "Be careful here, though: Applications for the possible use of fuzzy loops have to be carefully selected, and the degree of fuzzy control must be determined in advance.

That's because a significant number of loops will not be optimized with a low-end fuzzy loop, and the instrumentation can be damaged."

Is it just possible that the optimization of F.L. controllers should not be left to the judgment of a technician

with 15 minutes of training? Refer to the next paragraph....

21. F.L. guys claim that you do not have to be an expert to apply F.L. In fact, some of them say that any good technician can be taught in a few minutes to be an expert on Fuzzy-Logic controllers, replacing engineers with many months and years of schooling and experience.<sup>11</sup> Sure, they can say that any time, but I don't have to believe it. I am certainly not going to take this technician and set him in charge of my Nuclear Reactors. (Did they use Fuzzy Logic at Chernobyl?) (That's supposed to be a joke....)

22. F.L. guys claim that it is *easy* to put in the correct F.L. coefficients. If a ferry boat is heading for the dock, all you have to say is, "If velocity = (medium) and distance = (medium), then keep negative RPMs = (medium) to maintain the necessary deceleration."

Conversely, if an expert wants to set up a conventional control system, he has to know that the number of RPMs must be  $K \times (1 + V - (2ax)^{1/2})$ , where  $K = -860$  rpm, with all parameters expressed in (feet) and (seconds). He has to be smart enough to know that  $K = -860$ , and not  $+860$ , or  $-86$ ,  $-0.086$ , or  $-0.00086$ , or  $-460$ . But to make F.L. work, all you have to know is, to say "medium."

Well, don't look now, but if the conventional guy guesses wrong, at  $K = -86$ , and the ferry boat winds up perched on the dock, the F.L. guy can certainly make the same error, and HIS ferry boat will wind up on the dock, too. Hey, a factor of 10 error in either case will bring you to that same result. Fuzzy Logic computers are NOT clairvoyant. If you tell them to

do the wrong thing, they will not just "do the right thing," they will do what you tell them. Magic is not an appropriate element to invoke, nor to depend on....

23. It is sometimes claimed that F.L. can "learn" how to get the right answer—this is supposed to be a big advantage. However, Fuzzy Logic by itself cannot "learn" anything. If you want to get the F.L. to "learn," you have to use adaptive F.L. (non-trivial) or use Neural Networks. The knowledgeable guys with NeuFuz4 showed me that if you use Neural Networks to find a solution, and set the Membership Function, and generate the rules, these rules may be non-heuristic, not at all the same old rules, but improved rules with new advantages. Sounds impressive. Call them for details.<sup>12</sup>

Still, if you want to run the F.L. in a learning mode, be aware that a F.L. controller may make a lot of mistakes as it learns. Again, this is not the place to let loose the F.L. controller on your brand-new Nuclear Reactor, or your new catalytic cracking plant, or your epoxy resin kilns. F.L. controllers can be coached to learn a task when you have saved up a lot of data on how the system runs. It can look at the input data and the output data, and figure out how to control the plant. *BUT* only if you have that data, for all relevant regimes of control.

If you have a nuclear reactor, and if you had a Fuzzy controller for all normal operating modes, you would NOT use F.L. to control the system in the case of a breakdown, emergency, blow-up, melt-down, loss of pressure, thermal run-away, or any other non-standard mode, because F.L. only works well when you have run your system in that mode, and have a lot of data on that mode. You don't want to engineer your control of emergencies that way.

24. Further, it is claimed that F.L. can adapt to changing systems—as if conventional controllers could not. But conventional controllers can operate with adaptive coefficients. You can take a conventional PID (Proportional-Integral-Derivative) controller, and add on adaptive or self-tuning

# PEASE PORRIDGE

procedures. If you *know* the Control System Industry, you would know that. If you *didn't know* that, you might be willing to give F.L. some credit for miraculous advantages, which are not new advantages at all.

25. Remember the old saying, "To a man with a hammer, everything looks like a nail." Well, if a person knows how to apply Fuzzy Logic, and he doesn't know any other way to do it, I should not tell him that he cannot do the task. However, he has no right to tell me that is the only way, or the best way, just because it is the only way he knows....

26. F.L. has been stated<sup>13</sup> to be quite good at controlling the same kind of systems that people can, but with faster sampling, fewer mistakes, and more features. Anything you can do, slow as you are, a computer can do a little faster, better, and more consistently. Okay, that's not a silly statement: Anything I can do, that gets boring and repetitive, such as, starting and stopping a subway train smoothly and precisely, time after time, may be a good candidate for F.L. As far as I am concerned, that is arguably the best thing we can say about Fuzzy Logic.

27. Now, where are the cases where F.L. really is not suitable to do a good job? I suspect there are cases where the F.L. computing speed is not adequate, and maybe even a fast analog controller is necessary. Also, cases where timing, counting, integrating, and differentiating are required are not feasible unless you combine some F.L. and some conventional logic.

While we hate to be negative, it is important to be honest, because if there really are tasks that F.L. cannot do, we don't want to waste people's time on them. I think that F.L. people ought to make known, and *publicize*, cases where F.L. is really unsuitable, and, if possible, the reasons why. This is for the good of their industry.

28. Also, several people sent in reminders, that if you have a conventional controller, and it is working OK, there is usually not any advantage to throwing it out and replacing with a F.L. controller, despite all the HYPE

to the contrary. Any case where F.L. is shown to provide a WONDERFUL advantage over a conventional control system, is either a case where the conventional controller was not at all optimized, or, the system was nonlinear so the conventional controller could not do well.

Lastly, let's look at a couple of specific examples about Fuzzy Logic.

29. By the way, nobody yet has recollect where the original magazine article was, that said that a Fuzzy Logic Controller could control a subway train smoothly, but a "conventional" digital controller would jerk, jerk, jerk, jerk... Does anybody recall seeing that—can you tell me where that was published? I did a search, but nothing turned up....

30. On American Public Radio,<sup>14</sup> Daniel McNeill stated that the new 1993 Saturn has an improved automatic transmission, so that on steep upgrades, it uses F.L. to cut out surging, "hunting," and excessive shifting up and down.

WELL, the Saturn's transmission *has* been improved, and it *does* use Fuzzy Logic to provide automatic downshifts on downhills. But the transmission does NOT use F.L. to avoid "hunting" on upgrades.<sup>15</sup> It uses conventional hysteresis. Fuzzy Logic is NOT needed to do that, and is NOT used for that.

31. Also, I have always been skeptical that F.L. can make a subway train run much more smoothly than a good conventional controller. In a recent magazine,<sup>16</sup> Bart Kosko admits that the conventional train control system that was compared to Hitachi's F.L. controller, in Sendai, Japan, was pretty crude and jerky. "Conventional controllers start or stop a train by reacting to position markers that show how far the vehicle is from a station... the automated controller will apply the same brake pressure when a train is, say, 100 meters from a station, even if the train is going uphill or downhill."

Well, if the best competing "conventional" control system was so shoddily engineered, and was not intelligent enough, not adaptive enough, to apply the brakes differently, if the train was going fast or slow, uphill or down,

empty or fully loaded, then of course the Fuzzy Logic system deserved to win, but only by default, not by inherent superiority. If nobody had the sense to *move* the "apply brakes" markers 130 meters out, on a downhill, or 80 meters out, on an upgrade, then we are talking about relative levels of stupidity.

And Kosko observes, on the conventional controller, "because the controllers are rigidly programmed, the ride may be jerky..." Well, of course, a F.L. system can show advantages when compared to a system as crude as that, if nobody programmed the acceleration to feather off, to avoid  $dv^2/dt^2 = da/dt = \text{"jerk."}$  Also, I heard statements that during quiet times when human operators drive the trains to keep in practice, riders can tell this because the acceleration is not as smooth.

Well, of course the planners reserved the smoothest modes for the Fuzzy Logic system, and left the operator-controlled system lurchy, so it could not be as smooth. What would you expect? So much for the Old Straw Man business.

32. Also, some F.L. experts are *still* claiming that F.L. has some real inherent superiority over conventional (digital) controllers, because F.L. can represent a range of signals, whereas a conventional digital control system can only correspond to one ONE, or one ZERO.<sup>17</sup>

They still seem to be good at pretending that computers have only one bit—that computers do not have 8 (or more) bits in each digital word. Perhaps they try to perpetrate this story by pretending that Fuzzy Controllers work with miraculous awareness of the surrounding world, and do not depend on the *same* sensors and the *same* analog-to-digital converters that conventional digital controllers use.

If more people were aware that Fuzzy Controllers and Digital Controllers used the exact same input signals, the Fuzzy systems might seem less fantastic and revolutionary and amazing.

33. Even recently I heard of a system where F.L. engineers made a demonstration system to control the



# PEASE PORRIDGE

height of a ping-pong ball above a stream of air. The F.L. system was claimed to have taken only 15 days to develop, vs. 30 days for the "conventional" PID controller, which gave inferior results.

So, it sounds as if F.L. excelled in a fair test... But, when you think about it, this is obviously a very nonlinear system. Of course it is not surprising that a linear conventional controller does poorly, trying to handle a nonlinear problem. Of course, a well-designed F.L. controller can do a better job accommodating this kind of nonlinear problem.

The Fuzzy-Logic controller was obviously showcased—set up to look good. But showing that a conventional controller could not do well despite "30 days of development effort," shows how much work these people were willing to put into setting up their Straw Man!!

34. So we still see plenty of places where F.L. promoters have engaged in HYPE, and we have probably not seen the last of it. But if we protest to the editors, and refuse to accept stonewalling, we can force editors to pay some attention to truth and honesty. For example, in the IEEE Control Society,<sup>18</sup> several people wrote in to the Editors, to protest about misleading claims about Fuzzy Logic. Maybe the Fuzzy Logic Industry needs an Anti-Hype Committee, to rap the knuckles of people who make preposterous claims?

35. Conversely, I have seen a few examples where F.L. is proposed to offer modest advantages, perhaps 1 or 2 dB.<sup>19</sup> Advantages like that are much more likely to be true and to be believed. I think it is great if F.L. can compete with the best existing systems and show advantages. If F.L. shows advantages when competing with obsolete systems, that should be admitted.

36. Several people pointed out that there are a lot of engineers and scientists working with Fuzzy Logic, and just a small fraction of them generate most of the hype. So I want to apologize to anybody who has been offended by my broad accusations: if you ain't guilty, then I wasn't talking about you.

37. At a recent Fuzzy Logic Convention, several people said, "I hope we don't see any more demonstrations with the Inverted Pendulum, because it's boring and not very relevant." Well, F.L. people are still bragging about their advantages in stabilizing the Inverted Pendulums—Single, Double, and Triple. Maybe if they don't want to hear any more about it, maybe that is exactly why I should do it, without Fuzzy Logic, as a counter-example?...

38. At that Fuzzy Logic Convention, it was suggested (by several people, not just RAP), that maybe a new name should be developed for F.L., to take away the stigma and the negative connotations.

Maybe there should be a contest for the best name for F.L. I'll chip in \$10.00 for prizes, for the best new name. But in Japan, F.L. is not called by the name ai-mai, which means "fuzzy;" it is called, "Fa-Zhi." Maybe American promoters can figure out how to promote "ai-mai logic?"

39. In this vein, I talked to a smart engineer who has been earning his living, designing systems using F.L. His designs have been successful, and his clients have been delighted. So why can't he show me a good F.L. example? Because most of his recent clients have *forbidden* him to talk about his designs. Half of them were concerned that their competitors would find out how well the Fuzzy Logic worked—and the other half were scared that their customers would find out they were using Fuzzy Logic. Besides, he's too busy to show demos....

40. I do not think this is *the last word* on Fuzzy Logic, but I think we have at least raised the right questions. The answers will not come easily, because some of these people do not have much incentive to answer questions clearly.

But here's the situation as I see it. If we stick to our guns, then maybe we can instill enough honesty that people will be able to see where Fuzzy Logic really is appropriate.

Then, hopefully, they'll start to use it mainly for just those applications. And we really could use some concrete examples of where Fuzzy Logic is really

good, and where it is *not* good. I'm still waiting, and so are the readers of this column. We'll be interested to hear your stories and letters.

All for now. / Comments invited!  
RAP / Robert A. Pease / Engineer

Address:  
Mail Stop D2597A (note change!)  
National Semiconductor  
P.O. Box 58090  
Santa Clara, CA 95052-8090

## References:

9. "Fuzzy Logic," Bart Kosko and Satoru Isaka. *Scientific American*, July 1993, pp. 76-77.
10. "Fuzzy logic: A Clear Choice for temperature control," Haubold vom Berg, *Instruments and Control Systems*, June 1993, p. 41.
11. "Any technician can understand in few minutes the basic principles of fuzzy logic, and can apply this method with success even in the case of multivariable systems." Prof. C. Vibet, Evry, France; letter to *Fuzzy Sets and Systems*, Amsterdam, Netherlands.
12. NeuFuz4 from NSC; see note 5 in the last issue.
13. Private correspondence with Daniel Abramovitch, Hewlett-Packard Labs, Palo Alto, CA. June 30, 1993.
14. Daniel McNeill interviewed on "Marketplace Radio," KQED-FM, March 23, 1993 (6:49 P.M.)
15. "Saturn engineers have developed a '93 transmission control system—using fuzzy logic on the downhill side... Saturn doesn't use fuzzy for uphill driving because all the information is right there in front of the computer." *Automotive Industries*, Feb. 1993, pp. 149-150.
16. "Fuzzy logic," Bart Kosko and Satoru Isaka, *Scientific American*, July 1993, p. 78.
17. *Ibid.*, pp.76-77.
18. "On Fuzzy Control and Fuzzy Reviewing...," *IEEE Control Systems* magazine, June 1993, pp. 5-7, 86.
19. "Fuzzy-logic steers Electron Discharge Machining with finesse," Frederick Mason, *American Machinist* magazine, June 1993, pp. 31-34.



# BOB'S MAILBOX

**Dear Bob:**

The degree vs. no-degree issue is more complicated than your readership realizes. There is great value to experience, willingness to attack a problem, and native intelligence and intuition. A person is born with some qualities, some are developed through education and training, and some can only be acquired through years of working in the real world.

The technical professions have identified a body of knowledge representing the core knowledge one must know to be proficient in that profession. The degree is a certificate indicating that the holder has acquired mastery of that core knowledge. It doesn't certify that the holder is creative, hardworking, or pleasant to be around.

The permutations of degrees, experience, native ability, and a dozen or more other qualities are what make the whole engineer. Holding a degree is only one of these qualities; it shouldn't be overrated, but on the other hand, it shouldn't be underrated either.

I have worked as a software engineer (programmer) for 23 years. I recently received a masters degree in Computer Science. The knowledge that I acquired through the masters course work would have helped relatively little in my career.

Conversely, I can now do certain kinds of analysis and development that I couldn't previously. I expect the same to be true of other technical professions.

There is no reason why a non-degreed engineer shouldn't take the time to complete a degree. Between testing out lower-level courses and credit for work experience (post fact, it's called an independent study class), it is not a large burden.

A technical course of study is focused and relevant to work. Yes, any good school will want you to jump through a few hoops, but the fact is, they will work with you to tailor a

program if you work with them.

Assuming you have all the qualities that make a good professional engineer, why wouldn't you want to take the classes for a degree? You have to study continuously to keep up with new developments. So do your studying at a university where you can interact with a professor who has real expertise.

Your employer will help pay for the tuition and may even give you time off to attend classes. Time, money, value. Do you think you won't learn anything? You will certainly learn something you would not have learned just studying on your own.

With technology becoming more complex, and with the aerospace recession, certain job markets are more competitive. It may not be right, but the personnel people set standards that will prevent non-degreed individuals from being hired, and will lay off the non-degreed first.

**CORY K. HAMASAKI B.A., M.S.**  
*Alexandria, Va.*

*I sure agree with your first five paragraphs. But, there's "no reason" not to complete a degree? It's "not a large burden?" Hey, maybe I should steal the shoes off my baby's feet, ignore my family even more than I do, stop writing columns, and go back to school to learn how to design linear ICs from "a professor who has real expertise?"—RAP*

**Dear Bob:**

Back in May, you put out a challenge for Fuzzy Logic applications. This is not one. In fact, all I have read indicates that F.L. designers have never heard of feedback circuits in control systems.

The examples of F.L. that I have read are one-dimensional systems: If the temperature is such, then the "comfort" parameter falls into cold/normal/hot to such and such a degree. A simple feedback controller can easily handle this kind of problem. Fuzzy Logic is overkill for an applica-

tion that could be done more simply. Its only advantage is being able to make advertising claims that it's "Fuzzy Logic Controlled".

F.L. is an idiot level of Artificial Intelligence. AI can determine the correct identity or action from a complex input by using appropriate rules. The next higher level allows it to learn. The next level allows a "best guess" with incomplete data. For F.L. to shine, it must implement at least some of these principles. The degree to which a rule applies, and how it is applied, is determined by the data input. Rules modify the rules according to data. If data is missing or way out of line, fallback rules and constants may be used.

For example, F.L. that applies humidity as well as temperature would be a much more appropriate Fuzzy Logic application than a simple temperature controller. As humidity changes, the transitions between cold/comfortable/hot change position and possibly slope. At very-high humidity, the comfort zone may disappear. The controller would need to control both temperature and humidity through heaters, controllers, humidifiers, and dehumidifiers.

As long as F.L. is used in one-dimensional systems, it will flop. The more dimensions it uses, the better it will outperform other simpler feedback systems. However, the more dimensions it operates in, the more complex it becomes, and the more a true AI system may be appropriate.

I am not an expert in AI or F.L., but rather in communications systems. But I do believe that F.L. will fail until it is used to perform judgment of appropriate behavior with incomplete or complex data.

I also agree that many articles are more F.T. (Fuzzy Thinking) than Fuzzy Logic. Thanks for the breath of fresh air on F.T. (or was that F.L.?).

**PAUL M. SCHUMACHER**  
*Ademco Inc.*  
*Syosset, N.Y.*



# PICO

## ULTRA-MINIATURE Surface Mount Audio Transformers

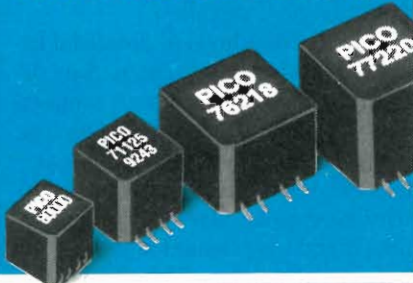

- **Manufactured and tested to MIL-T-27**
- **Frequency range 20 Hz to 250 KHz**
- **Available from 100 milliwatts to 3 watts**
- **Impedance from 20 ohms to 100 K ohms**
- **Operating temperature -55°C to +130°C**
- **Low profile .2" ht.**

PICO surface mount units utilize materials and methods to withstand extreme temperature (220°C) of vapor phase, I.R., and other reflow procedures without degradation of electrical or mechanical characteristics.

Delivery—  
stock to one week

See EEM  
or send direct  
for **Free PICO Catalog.**  
Call toll free **800-431-1064**  
in NY call **914-699-5514**  
FAX **914-699-5565**

**PICO Electronics, Inc.**

453 N. MacQuesten Pkwy., Mt. Vernon, N.Y. 10552

CIRCLE 205 FOR U.S. RESPONSE

CIRCLE 206 FOR RESPONSE OUTSIDE THE U.S.

## PEASE PORRIDGE

*Many demonstrations of new technology are greatly simplified. But most F.L. examples give no clear explanation of what works—or why! I hope my last two columns helped clarify that.—RAP*

**Dear Bob:**

How I have waited to catch you in an error! The large Van de Graaff generators used at most physics research labs are horizontal—not vertical as you implied in the Oct. 1 column, “What’s All This ESD Stuff, Anyhow?”

I can now die a happy man. (I might want to put it off a few years, though, since I am only 33.)

**CHUCK McCOWN**

**Data Com**

**Quincy, Ill.**

*Just like I said: Since most conveyor belts are vertical, those horizontal Van de Graaff generators are perpendicular.... I once thought I’d made an error—but that was a mistake....—RAP*

**Dear Bob:**

I greatly enjoyed your column, “What’s All This Ground Noise Stuff, Anyhow?” in the June 24 Analog Applications Special Issue. The importance of being able to make an accurate measurement can not be understated. I remember “Doc” Edgerton telling our circuit design class (circa 1955), “You guys will never be good engineers until you learn to take a measurement!” That admonition is probably truer today than it was back then, when you could almost get by measuring voltages with a wet finger and power levels with your sense of touch (or smell—depending on the degree of overload).

One statement you made in your article is more incorrect than not, and should be clarified. You say in reference to magnetic noises, “Unfortunately, copper or aluminum will not reject or attenuate these magnetic noises.” If you check almost any book on EMI reduction techniques, you’ll find references to attenuating ac magnetic fields with “reflective shielding” by using conductive enclosures made of those very materials.

An ac magnetic field induces a current in the shield, which creates an opposing field. I’m sure someone who

remembers his/her electromagnetic field theory better than I do could derive a rigorous proof showing that ac magnetic fields are attenuated by conductive enclosures. I suspect the proof would show that even a dc magnetic field would not penetrate a completely closed box made of infinitely-conductive material. The material I’ve read states that reflective shielding is more effective than using magnetic materials above about 15 kHz, and the thickness of a reflective enclosure need only be about three times the skin depth of the material at the lowest frequency you’re trying to attenuate. Holes for leads, adjustment tools, etc., should be kept as small as possible. Better one hole per wire than one big hole to take a whole bundle. The old “loop size” thing again.

Sometime last year I read a technical note from Hewlett-Packard that described the extremes they took to provide magnetic shielding for the front end of a wideband measuring instrument, with a multiple-layer shield that was constructed out of Mumetal for low frequencies and copper for higher frequencies.

I recently had to reduce the external 25-kHz magnetic fields produced by a small switching power supply in a spacecraft system. The 25-kHz H-field, as measured with a shielded loop antenna a few inches away from the supply, was about 20 dB over the allowable limit. I reduced these emissions over 30 dB by surrounding the supply with a cigarette-pack-size aluminum box with 1/16-in. thick walls and cover. To get maximum attenuation, I had to clamp down the cover with countless screws. An alternative would have been to use a metal mesh conductive gasket between the cover and the box, and fewer fasteners.

**JEFFRY A. WISNIA**

**MIT 57 EE**

**Jeffrey Wisnia and Associates  
Winchester, Mass.**

*Thanks for correcting my ignorance. Your comments are of great value—examples of problems in the real world, indicating that these very tricky principles are not well known. Many people read my Ground Noise column, but only you wrote in to educate us!—RAP*



# WHAT'S ALL THIS FLOOBYDUST STUFF, ANYHOW? (1993)

As we mentioned in this column a year ago, "floobydust" is a recently-coined term for "miscellaneous" or "pot-pourri," a regular jumble of ideas. Am I wrong??

• Back on March 4 (ELECTRONIC DESIGN, p. 108) I wrote that the Electronics Flea Market at Foothill College in Los Altos, Calif., runs on the second Saturday of every month from April through October. Unfortunately, the last Electronics Flea Market of the season is September. Hope I didn't mislead you too badly. (I wished there was one in October, but



**BOB PEASE**  
OBTAINED A BSEE FROM MIT IN 1961 AND IS STAFF SCIENTIST AT NATIONAL SEMICONDUCTOR CORP., SANTA CLARA, CALIF.

I guess the guys who run it have a right to take a break.)

• Also in March, on the same page, I indicated that you could buy a plastic raincoat for your camcorder for only \$150. NOT a great buy. Last month, I was wandering through Fry's, a very good electronics store in Sunnyvale, Calif.,<sup>1</sup> and I found a raincoat for small camcorders that I could afford—\$14.95—by Ambico. Rather

than an expensive optically flat glass front, it just has an open hood. I've used an umbrella while shooting with my camcorder in light rain, and this should work at least as well. It will be a lot lighter and more compact. If your camcorder is less compact than 10

inches long, contact the manufacturer<sup>2</sup> for advice on what model will fit your machine.

• I'd like to be able to tell you about a simple circuit for recharging your alkaline flashlight batteries. A reader in New Zealand clipped it out of a British electronics magazine<sup>3</sup>. It proposed that a forward pulse of charging current followed by a negative pulse would be compatible with the alkaline's chemistry and work sufficiently, as opposed to a dc recharging current, which works badly. I'd like to be able to recommend this circuit, but when I built it and checked it out, it ran badly. So far, I haven't been able to make it work adequately. If I can make it work, I'll let you know.

• I placed an order for a "Supercharger" that's supposed to be able to recharge ordinary alkaline flashlight cells. They said it would take 8 weeks, and that is true. I ordered it in August and it's now the end of November, and I'm still waiting. If I can get it to work, I'll let you know, and how well. It may be an improved variation of the circuit in the previous paragraph. About \$59.

• I also bought a Ray-O-Vac "Renewal" recharger (\$30) for charging up the Ray-O-Vac "Renewal" alkaline batteries<sup>4</sup>. Allegedly, these can be recharged 25 times. However, each time you recharge the battery, the capacity shrinks a little more. Even though you recharge the battery 25 times, you only get as much energy as 8 new batteries. Still, if you use a lot of Alkaline batteries, this could pay for itself fairly quickly. Even as cell capacity decreases, the cell still holds 3X or 2X or 1X as much as a good NiCd battery, which costs more but can be recycled more than 100 times. So the Ray-O-Vac Renewal system can definitely

save you some money compared to throwing away flashlight batteries. It may also have advantages if NiCds aren't suitable. However, I've tried several times to get basic technical information from Ray-O-Vac, and they have yet to respond.

• As I mentioned earlier, I think I can recharge my camcorder's NiCds on long hiking trips with a special high-efficiency switch-mode regulator that uses Alkaline D-cells as the main energy source. Alkalines hold 3X more energy (per ounce) than just carrying more NiCds. However, we've been too busy to build this switcher, so that will have to wait a little more. Sigh. Meanwhile, on my summer back-packing trips, I just carried my old hand-crank gear-motor, and it continued to work well.

• A friend tipped me off to the advantages of zinc-air batteries.<sup>5</sup> These can put out 2X more energy per ounce than alkaline D cells, which in turn can put out 5X more energy than lead-acid cells, or 3X more than NiCds. So you could use 1 pound of zinc-air cells to recharge 1 pound of NiCds six times! That sounds like the way to go, except that if you try to draw too much current from the zinc-air cells, they go to pot. If you really want to get the full energy from a zinc-air cell, you have to spread that energy transfer *very carefully* out over 200 hours. In other words, they're not ideal for a fast recharge. Also, they're not cheap—maybe cheaper than lithiums, but cost per watt-hour is higher than alkaline D-cells; and availability is quite poor, special order and all that.

• Several people asked, "Why do you *have to* double-clutch a VW?" I had to reply, you do not *have to*, but it is fun, it sounds and feels right, and keeps you in practice. One reader said that, when starting up in traffic, he doesn't just shift from neutral into first, but from neutral to second to first. In a car without synchromesh on first gear, this saves on wear and tear. I confirm that I also usually do that, just to share the wear on all of the synchronizers—even though I don't have to. Also, I have a habit, after I shift into fourth gear, to reach down and check my handbrake to make sure

# PEASE PORRIDGE

it is off. About 99% of the time it is off. Just a precaution.

- April is coming, and we shall have a fine kettle of hoaxes in the April 1 issue. Meanwhile, those of you who are thoughtful about audio equipment will be pleased to learn of *The Audio Critic* magazine.<sup>6</sup> It debunks various myths and ridiculous claims about super-high-end audio equipment, when claims are made that obviously can't be proven but rather must be accepted on faith. If you could use an occasional sanity check, their magazine (quarterly) is a good investment. Their "Hip Boots" column is priceless.

- I got dozens of checklists from readers, hiking checklists and lists for business trips, with lots of interesting ideas. I sent out dozens of my basic lists, too. On my back-packing checklist, I have amended it to reject any shirts with less than 27 inches from the top of the shoulder to the bottom of the side seam. Shirts shorter than that tend to not stay tucked in, and are uncomfortable.

- A friend up in Oregon suggested that if you want to get a floating scope with low capacitance to ground, the Fluke Model 97 is quite compact.<sup>7</sup> It has less than 8 pF, much less than most scopes. This low capacitance can help improve rejection of ground noises.... In the old days, if you really wanted to get the best isolation of a circuit, you did not use a Teflon spacer. Instead, you hung your circuit from a silk thread. I once measured some silk thread. I figured out that a 3-inch piece of silk thread has a resistance of about  $3 \times 10^{15}$  ohms in dry weather, and a capacitance about 0.02 pF more than the air itself. Not bad. The Fluke 97 weighs only four pounds, and needs only about eight strands of silk thread....

- Doctor Science has a brand new book out, just in time for Christmas: *Dr. Science's Book of Shocking Domestic Revelations*—marvelous lunacy and advice on home repairs and construction.... Very reasonable at \$17.50 (includes shipping).<sup>8</sup> To order, call 1-800-989-DUCK. If you want to order on CD-ROM, hold your breath and count by ones to  $6 \times 10^{23}$ . It should be ready by then.

- In the field of battery charging

and alternative energy, I recommend *Home Power*—*The Hands-on Journal of Home-Made Power*.<sup>9</sup> This is good reading for people who are interested in cost-effective systems, not the fancy battery-power systems that only a marijuana-grower can afford. Practical insights. Low smarm content. Examples of good engineering using recycled, home-engineered parts for thoughtful cost-effective systems. It's well-written and doesn't insult your intelligence.

- I have heard that Whirlpool's \$30-million prize-winning high-efficiency refrigerator is supposed to use Fuzzy Logic. One report claimed that it uses F.L. "to make the compressor more efficient." But another guy said, baloney—it just uses F.L. to reschedule the Defrost cycle so it won't waste energy doing a Defrost if no Defrost is needed. Does anybody know what the truth is?

- Most F.L. controllers that we see have one input for (x) and one input for (dx/dt). The Fuzzy guys thus have two knobs. I usually run my controller with one input for x, one for dx/dt, and one for  $\int x \cdot dt$ . So I have three paths, commonly known as Proportional, Integral, Derivative (usually called PID), and thus I have 3 knobs. The Fuzzy guys pretend they don't need any Integral term—they can make just as good a controller for a linear system with 2 knobs as I can with 3—but they're wrong. The Shadow Knows!! More later...

Continuing on the subject of Fuzzy Logic, I must recommend a newsletter<sup>10</sup> from one of the few promoters of F.L. who is a *real engineer*, not just an ivory-tower theoretician. The guy, Dave Brubaker, is thoughtful about solving *real problems* with F.L. I have learned more positive, useful information about F.L. from Dave's newsletter than from everybody else put together. NOT just platitudes. Ask him for a couple samples of his newsletter, and information on how to order it for \$24 per year.

All for now. / Comments invited!  
RAP / Robert A. Pease / Engineer

Address:  
Mail Stop D2597A

National Semiconductor  
P.O. Box 58090  
Santa Clara, CA 95052-8090

## References:

1. Fry's Electronics, 1177 Kern Ave., just off Lawrence Expressway, about 1/3 mile south of U.S. 101, Sunnyvale, Calif. Great assortment of electronic merchandise, from fuses and resistors and ICs up to fancy TV and electronic systems. Also stores in Palo Alto and Fremont. Inquire at 408-733-1770, 415-496-6000, or 510-770-3797.
2. Ambico Inc., 50 Maple St., Norwood, N.J. 07648; phone: 1-800-621-1106.
3. "Better use of dry batteries," Rod Cooper, *Practical Electronics*, July 1986.
4. Ray-O-Vac "Renewal" rechargeable alkaline battery system. Charger costs only \$30, nicely built, a real bargain. Special "Renewal" alkaline cells cost 2X more than ordinary alkaline cells; only the Renewal cells can be recharged in the recharger. Available in good department stores or electronics stores. I bought mine in Target.
5. Eveready DA412P zinc-air battery can put out 4.8 V  $\times$  6.5 A-hr. That's about as much energy as 4 alkaline C-cells or 2 D-cells, but it weighs only 3.7 ounces, or a factor of 2.7 less. It costs \$12 or a factor of 4.5 more than the alkaline cells. You can get this energy only if you draw less than 40 mA for longer than 160 hours. Minimum order is 75 pieces. Zinc-air is great for hearing aids—and for astronauts.
6. *The Audio Critic* magazine: published quarterly, \$24 per year, by: Critic Publications Inc., 1380 Masi Rd., Quakertown, PA 18951.
7. Fluke Corp. Model 97, handheld meter and 50-MHz oscilloscope, 4 lb., \$1950. Phone: 1-800-44-FLUKE.
8. *Dr. Science's Book of Shocking Domestic Revelations*, ISBN 0-688-11444-X. \$17.50 includes shipping. To order, call 1-800-989-DUCK.
9. *Home Power*, published bi-monthly for \$15 per year, by Home Power, P.O. Box 520, Ashland, OR 97520.
10. David Brubaker, The Huntington Group, 883 Santa Cruz Ave., Suite 27, Menlo Park, CA 94025-4669.

# WHAT'S ALL THIS TIME MANAGEMENT STUFF, ANYHOW?

Once upon a time, in 1956, I was attending Mount Hermon School in central Massachusetts. At the end of the school year, I was asked to stay over to help out at Commencement ceremonies. I didn't think anything of it at the time. I wandered into the Commencement ceremonies, and was quite surprised when they announced that the winner of the second prize for writing Book Reports, for the Junior Class, was Robert A. Pease.

I nonchalantly ambled up to accept the prize—and tried to recollect—when did I write any Book Reports?



**BOB PEASE**  
OBTAINED A BSEE FROM MIT IN 1961 AND IS STAFF SCIENTIST AT NATIONAL SEMICONDUCTOR CORP., SANTA CLARA, CALIF.

After a good deal of thought, I remembered the gray January afternoon when, after lunch, I went down to the Library with a high-priority assignment: Because of my procrastination, I had to read 3 books and write book reports on all 3 by 5:00 PM—on that day. Well, I sort of read 3 books *real fast* and wrote a report about each book, and I handed in the reports by 5:00 PM. As a matter of fact, I did recollect that my English teacher, Mr. Jack Baldwin, had not returned those book reports to me....

And then in June the English Department judged that I had shown some *excellence* in the art of writing about some books I had read. To this

day, I don't have any record of what I wrote. I don't think I ever did get those 3 book reports back from my teacher, nor do I even recall exactly what 3 books I wrote about. But I must have done a pretty good job of planning what I wanted to say on the first draft, because that was the only draft that ever got done....

The other day I went to take some training in a course on "Time Management." I showed up *promptly* at 8:30 AM and settled down to hear Tom, the instructor ask, "What if you haven't fulfilled the tasks you had to do? What do you feel?" Then we all knew how to speak out, "GUILT." And the instructor went on, "... and guilt, added to procrastination, tends to causes paralysis, and forces your productivity even lower....leading to more paralysis...." LOWER?

At exactly that point, I began to recall the circumstances of my book reports. Did my procrastination in writing book reports cause me to be guilty and lose all productivity? I knew I had a job to do, so I did it. And I was rewarded for "a job well done." Guilt and paralysis did *not* take over.

I was especially reminded of this because at the exact same time that I was listening to Tom explain about guilt, procrastination, and paralysis, I was not paralyzed—I was writing down the specs for a new data converter. I had designed the circuit a couple days ago, and a report was due. I had not had enough time to write down the specs, even though I knew in my head what I meant to do. So I documented my notions on paper during the "Time Management" lecture....

In the fall of 1959, a couple years after I won that Book Review award, I was going to MIT, living out in the

slums of Cambridge. I decided to try to live within my budget. I got a notebook, and I logged in the money I had at the beginning of the term—perhaps \$125.50, as I recall, and then I wrote down all my purchases and expenses. As I approached the end of the term, my budget notebook said that I had \$2.85 left, after subtracting all my expenses from my balances. I looked in my wallet. I had \$12.85 left. I double-checked my subtraction. No errors. So I decided that I had two choices: either throw away that discrepant \$10 bill, or, throw away the notebook. After 2 seconds, I decided to throw away the notebook, *not* the \$10 bill. I never went back to trying to have a "budget" again, if it would lead me to a choice as silly as that.

Try and think of a budget you can beat—mere dollars. Now think of a budget you can hardly beat—minutes and hours. (Let's ignore strange time-zone games.) If all 24 hours in a day were available for all tasks, would you still need to borrow some more hours? If time is money, is there anything more valuable, more irreplaceable, than *time*?

I value my time. I don't get up at 5:30 AM, work all day, and then study things until after midnight as a joke. So why do we play games with time? As I said, I value my time. Often on a weekday evening, I may "borrow" an hour from the weekend. When I get to Saturday, I am *shot*, and I know I have built up a sleep deficit. I know I have to pay back some of my sleep debt. I need to take a nap. Okay.

After a nap on Saturday afternoon, and perhaps on Sunday, too, I have gotten honest enough to balance my *sleep* budget. I pay my debts. I can live through next week....

Once the Time Management lecturer, Tom, finished explaining about paralysis, he suggested that we should list, describe, define, and prioritize our goals and objectives. If we *say* that our families are first, but we *admit* that on 5 days a week our higher priorities are for taking care of our job, is that bad? No, being honest about our priorities is probably *good*. Is it bad for RAP to have a priority when it comes to replying to any



# PICO

## Multiplex Data BUS Pulse Transformers **MIL-STD-1553**

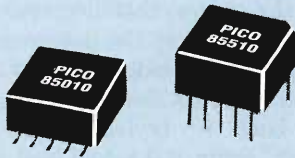

Actual Size  
**.4" x .4" x .2"Ht.**

- **Surface Mount**
- **Plug-In**
- **QPL Standards  
MIL-T-21038/27C**
- **MIL-STD-1553**

These pulse transformers manufactured to MIL-STD-1553 COMMAND/RESPONSE MULTI-PLEX DATA BUS requirements. They also are manufactured to MIL-T-21038/27C specifications and are designed to meet MAC AIR SPECIFICATIONS A3818, A5690, A5232 and A4905.

All of these transformers exhibit superior electrical performance. Common mode rejection ratio is greater than 45dB at 1 MHz. Input impedance is greater than 3000 ohms over the band from 75 kHz to 1MHz at 1V rms. This series possesses exceptional waveform integrity: Rise time and fall time is less than 100 nanoseconds. Overshoot and ringing is less than  $\pm 1V$  peak. Droop is less than 20%.

**Delivery—  
stock to one week**

See EEM  
or send direct  
for **Free PICO Catalog.**  
Call toll free **800-431-1064**  
in NY call **914-699-5514**  
FAX **914-699-5565**

**PICO Electronics, Inc.**

453 N. MacQuesten Pkwy., Mt. Vernon, N.Y. 10552

CIRCLE 190 FOR U.S. RESPONSE  
CIRCLE 191 FOR RESPONSE OUTSIDE THE U.S.

## PEASE PORRIDGE

reader who writes a letter or asks a question? The answer may not be so simple.

But the Time Management instructor went on to list all of the things we typically want to do in a day. Even without wasting any time, if we allocate time only to tasks that are of high value, there's not any time left at the end of the day, he observed. "If I'm doing one thing, then I'm not doing another—so I am procrastinating...."

Then we went to lunch. I had a choice: I could either make a couple phone calls, or get some info off a computer, or eat lunch. What was my highest priority? Easy—I did all three. I munched a sandwich and waited for the computer to boot up. Called Bob Milne and left a note on his phone machine. Ate a cookie and talked to a couple other guys while ordering the printer to print out. Obviously, one-track-minded people who can only do one thing at a time would have a disadvantage. I know a guy who used to read a book as he drove to work.

Still, no matter how carefully you manage your time and tasks, I'm sure that you, too, tend to run out of time before you run out of tasks. Everybody who is any good at anything always gets loaded up with more tasks than he/she can conveniently accomplish—and is always too busy....

What if I could buy a little machine, no bigger than a VCR, that I could set beside my bed? After I turn it on, I go to bed, good and tired, at 3 AM. Then I would awaken at 5 AM feeling as refreshed as if I had 8 hours of sleep. Maybe 1 day per week I would need to put in a little debt-make-up sleep, but that's not a big deal. WHAT amount of \$\$\$\$ would you be willing to charge on your VISA card to pay for that box—the box that gives you back 6 hours per day??? Would it help you get your job done, and your tasks around the house, too? Unfortunately, at this time I do not know where you can buy that "time machine." But I have been told that when it becomes available, it will have a Russian patent number on it.

The lecturer from Franklin Time Management did not try to brow-beat us into using his "Daily Planner System." He just pointed out that any-

body who already had enough money for financial security for his family for the rest of his life did not have to worry about saving time. But the rest of us might consider that if there's a system which makes us more efficient so that we can get all our work done promptly, and then have time left over for FUN and personal PROFIT, then we really might want to exploit that system. A good pitch—a wise salesman, proposing to sell us the one thing we can't buy anywhere—a "time machine."

Should I worry about my usage of my time? Should I feel *guilty*? Well, it's not the kind of thing that worrying, or panicking a lot, will make better. If I am doing my job, then inventing new worries out of thin air will not help anybody.... However, being dishonest about my time is not so good, compared to just being honest. If I'm able to keep my boss happy, but my kids never see me, and my wife gets frustrated because I'm never around when she needs me, maybe my allocation of time isn't so good. Maybe I could use some kind of "time machine" to help me find the time to do the things I really want to do.

After all, some of the things I use my time for aren't as valuable as others—though I may not find out exactly which ones they are for many years. What if I spend a few hours to help some guy with a thorny problem? Can I justify that if the guy only works for a little company, not a huge corporation? Well, sometimes it does make the customer feel really good about me and my products and my company. Sometimes this makes good business for his company and mine, too. And other times I guess I probably wasted my time. But, even the Time Management Experts were honest enough to reprint a quote by Francois Auguste Rodin: "Nothing is a waste of time if you use the experience wisely."

All for now. / Comments invited!  
RAP / Robert A. Pease / Engineer

Address:  
Mail Stop D2597A  
National Semiconductor  
P.O. Box 58090  
Santa Clara, CA 95052-8090

## PEASE PORRIDGE



# BOB'S MAILBOX

### Dear Mr. Pease

I am one of the young promoters of Fuzzy Logic, or "F.L. Guys" you spoke about in your "What's All This Fuzzy Logic Stuff, Anyhow? (Part II and III)." But you may find it somewhat surprising that I agree with much of what you said. There are far too many people out there making exaggerated claims about how F.L. can be applied and what benefits should be expected. It is truly unfortunate that the hyping of F.L. as a panacea has obscured the fact that, properly applied, F.L. can provide real benefits.

Many of the people who have given F.L. a bad name are the academic types who, as you stated, speak as if they are "preaching to the converted." I am as tired of hearing about how F.L. will give you "more robust control" as you are about hearing about probability. Working for a factory automation company, I do not have the luxury of strictly dealing with theory (like the academics); I have to provide tangible benefits.

Omron has been a leader in the development of F.L. in various forms—microcontrollers, software and development tools, controllers, and turnkey systems. In the U.S., our focus has been on automation products. We are not actively marketing chips and software at this time.

It's important to note that in the introductory stages of anything new, it's easy to get carried away with the potential impact. (America's space program serves as an example. Weren't we supposed to have colonized Mars by now?) The promise of F.L. was no different. Today, though, as suppliers and supporters become more familiar with F.L., we've also become more aware of its practical applications and implications. Much of the boasting has ceased, though not totally disappeared.

At Omron, we've never made a blanket statement that F.L. is superior to conventional systems. The fact that our single-loop controllers (the

ready-to-use 1/4 and 1/8 DIN types, not microcontrollers) use a hybrid of PID and F.L. processing speaks to this point. PID control alone is a perfectly acceptable control method in about 80% of the process applications we see. However, the other 20% are critical applications that are susceptible to process upsets, where the PID parameters cannot be tuned to provide the desired combination of responsiveness and stability. With our controllers, the PID constants can be tuned for stability, while the F.L. part of the algorithm deals with responding to the disturbance.

Our customers using this particular controller report significant improvement of process control using the F.L.-based product over the PID product (also Omron's). These customers are in the food, pulp and paper, pharmaceutical, medical products, semiconductor, and other industries. When one of these customers allows us to write about the application, we'll be sure to send you the details. Until then, we accept customer orders for more F.L.-based controllers as proof that they work better for them in their applications.

Omron's tests of performance in controlled environments yielded a 50% improvement in controller response time over PID-only controllers. We fully understand, though, that this improvement in response time is important for only some of our customers. But, for those customers, the only really important thing is that the F.L. product solved their problem.

Like you, Omron also disagrees with the idea that F.L. users don't need models to develop a system. Our seminars on F.L. emphasize the need for a thorough understanding of the system to be controlled, and a clear understanding of the overall objectives of the project before F.L. can be successfully applied. Our stance is if a conventional controller can provide the necessary performance, USE IT! If not, a F.L.-based product may solve the problem.

As with virtually everything else in life, it comes down to a cost-benefit compromise. You mentioned in your column that a PID algorithm could be written to accomplish the same performance as the F.L. solution; all that's needed is a faster computer. The question then is how fast? And is this faster computer available at a cost and engineering development level that's acceptable to the customer?

Thanks for helping to bring the benefits of Fuzzy Logic into focus. It is not a panacea as some zealots might claim, nor is it a boondoggle of unfulfilled promises. Fuzzy Logic is simply another tool in the engineer's toolbox—an alternate control processing technique for use alone or in combination with other techniques for applications that have resisted other methods, or that require F.L.'s innate ability to capture the intuition and judgment of a skilled expert.

### ROBERT NEAGLE

#### Product Marketing Specialist

#### Omron Electronics Inc.

#### Schaumburg, Ill.

*Thank you for the Sanity Check. When you and I are able to provide more details of where F.L. can provide real benefits, we'll speak up. However, some experts tell me that F.L. needs less computing power to do a job (vs. conventional controllers). And other experts say that in many cases, F.L. needs more computing power. Nothing simple in the whole world!—RAP*

### Dear Mr. Pease:

While reading your recent "What's All This Fuzzy Logic Stuff, Anyhow? (Part II)" column, I was reminded of a past experience that may pertain somewhat to the state of the Fuzzy Logic community. Some years ago, at a different firm, we hired a software engineer, Bob. In a strange sort of way, Bob was very bright. He was to a great extent self-educated. While that is not a bad thing, Bob's knowledge ended up having unexpected gaps, which, unfortunately, he had lit-

# PEASE PORRIDGE

tle interest in filling. Being clever, he had developed many interesting techniques to deal with design problems over the years. He was very proud of these, and considered them to be original and unique. But, unknown to Bob, many of them were simply traditional designs that Bob had rediscovered.

I remember one case in which he proudly described how he would make his software "anticipate" the arrival of a certain external event that occurred at fairly uniform, although not exactly known, time intervals. He began a long discussion explaining how this miracle worked, using a combination of the system's local timebase and some of his software. Part way through, I interrupted him, and tried to tell him that the thing he was describing had a name. It was called a phase-locked loop. Bob countered that I couldn't have understood him correctly. *He* had invented this thing two years ago, and *he* had not named it a PLL.

I explained that I understood correctly, and although his terms were unconventional, he was indeed describing a PLL. PLLs were not invented two years ago, but have been used for about half a century. I explained that although the original ones were analog circuits, purely digital ones also existed. Using a fixed clock and a variable modulus counter (rather than an analog VCO), they were very common in systems that recovered synchronous serial data, and could be found in various popular datacom peripheral chips.

I explained that Bob's code was simply a software implementation of one of these digital PLLs. These software implementations were not unusual, being found in some automobile-engine timing-control software, among other places. Of course, Bob had never seen anyone else's digital PLL, although he had used products full of them. I suspect he may even have seen an analog one, but never made the connection between that circuit and his "invention."

Bob was very resistant to my claim that textbooks contained well-documented analysis techniques for his invention, since he, the inventor, had to tune his creation by trial and error. But I don't think he ever had the

slightest interest in looking through such texts. He didn't accept that we already understood his invention in detail, or that we already had enough experience with PLLs to know that it was not the best answer to the current problem.

Bob deserves a lot of credit for having independently reinvented something as wonderful as a PLL. But, because of his limited background, he failed to understand that what he had created was not all that impressive, and was very unreceptive to having this pointed out to him.

I suspect that some F.L. proponents may have similarly weak backgrounds, and may not have seen examples of *well-designed* traditional control systems. Bob's PLL implementation was not immediately recognizable as a PLL, even though in the end it proved to be a classical device. I further suspect that some of the things we see in Fuzzy systems are, in fact, techniques that have been in use for some time to enhance traditional controllers, but mapped into a different domain where they are no longer recognizable.

I don't mean to imply that F.L. has not embodied classical control equations. I am referring to the clamps, limiters, nonlinear signal conditioners, "anti-windup" circuits, hysteresis, feedforward, etc., which are often part of real (if not textbook) controllers. Some of these features long predate software, being found in analog and even some ancient pneumatic/mechanical controllers.

An advantage of F.L. may be that it can produce a very good controller by following some analytical design procedure. However, the enhancements added to traditional controllers to improve their performance were generally the result of the skill and experience of the engineer.

There have always been physical systems that traditional control textbooks regard as more or less uncontrollable, or at least very difficult to control. When such systems are easily brought under control by F.L. techniques (and some have been), we have an accomplishment worthy of respect. But, most of the commercial products claiming to use F.L. today do not seem

to fall into this classification. Therefore, I find myself in agreement that F.L. is not quite as revolutionary as its proponents claim.

**ERIC KINAST**  
*Engineering Manager*  
*Sonntek Inc.*  
*Woodcliff Lake, N.J.*

*Every engineer must be prepared to invent a circuit or function that he/she has never seen before. If it then turns out, it's already been done before, there's no point in getting mad! As I mentioned in my 1992 columns (ELECTRONIC DESIGN, Jan. 9, p.41 and Nov. 12, p.80) the PLL was developed as early as 1783, for adjusting clocks and watches. Fuzzy Logic may be a useful tool to help us handle nonlinearity. But it doesn't usually give ideal results just by pushing a button—the engineer still has to provide skill, experience, and thinking.—RAP*

**Dear Bob:**

In your femtoamp column in the Sept. 2 issue, you mentioned placing guard rings on the bottom and possibly the top of the pc board to stop stray leakage currents from reaching sensitive nodes. While working at a company here in Cleveland that makes femtoamp meters, I also learned to "stitch" the pc board. In other words, to put numerous plated through-holes between the top and bottom guard rings. We found conduction down some of the fibers under the surface, so we added the holes to break these conduction paths. I don't know if this was just a process problem making pc boards 15 years ago, or if it still exists. But I still stitch boards around sensitive nodes.

**GARY BERGSTROM**  
*Bergstrom Consulting*  
*Chagrin Falls, Ohio*

*I've stitched my pc boards for different reasons, but you are right in this case. Thanks.—RAP*

All for now. / Comments invited!  
RAP / Robert A. Pease / Engineer

Address:  
Mail Stop D2597A  
National Semiconductor  
P.O. Box 58090  
Santa Clara, CA 95052-8090



# WHAT'S ALL THIS QUALITY STUFF, ANYHOW?

**W**ELLLL—I have been figuring for years that someday I would write about “quality.” But aside from saying that we’re all, of course, in favor of the *HIGHEST POSSIBLE QUALITY*, what else is there to say? Wouldn’t that make a very short column? Yet despite the truism just listed above, very few of us readers drive a Rolls Royce.

So perhaps we should admit that we’re all interested in very good quality at a reasonable price—a Volkswagen or Ford price, maybe even a Cadillac, Acura, or Mercedes price—very good quality, *appropriate* quality, but not necessarily the *highest possible* quality.

I still recall very plainly that VW used to advertise and brag that they had more QC inspectors than they had cars, and those old VW beetles had pretty good quality. Of course, it might be that the inspectors forced the production engineers to go back and solve the design and manufacturing problems. Maybe that’s a

back-door way to achieve good quality. Anyhow, I still like my old Beetle, running reliably at 287,000 miles. It’s not the highest quality, maybe not as good as a Rolls Royce, but it is *appropriate* quality.

I recollect the story of one of the

pioneering transistor companies, back in the ‘60s. They had agreed to ship to their customers transistors with an AQL (Acceptable Quality Level) of 2%, which was pretty good for those days. So the tester would test 98 good parts and put them in the box. Then, following her instructions, she would add 2 bad transistors to finish off the box, thus bringing the quality to the exact level desired. This went on for some time, until one of the customers got suspicious, because the two bad transistors were always in the *same corner of the box!* Then things were changed....

Now let’s get serious. I propose that not everybody really wants to buy parts with the highest quality and the smallest AQL. Let’s consider a few practical examples. If I’m testing some gates or flip-flops, the output had better be about right, with a very high confidence, on every test. If I make 20,000 bad dice in 1,000,000, and I only reject 19,700 of them, you as a purchaser might be quite displeased to get an incoming quality rate of 300 ppm. So, it is pretty clear-cut that for ordinary commodity ICs, the parts and the testing should be very good so that no bad parts get to the customers. Many IC manufacturers do well at this.

Ah, but what about precision analog components? Precision op amps, 16-bit DACs, low-noise references? Can they always be tested with full precision and confidence?

What about a high-gain op-amp, such as OP-07? If the output swing is a 10-V step (either + or -), then the maximum input error ( $\Delta V$ ) must be less than 50  $\mu V$ . Further, it must be less than 50  $\mu V$  with a VERY HIGH confidence level every time you measure it. What if it is 34  $\mu V$  p-p sometimes when you test it, and 38  $\mu V$  p-p

other times, and 30  $\mu V$  another time? Then if you see 47  $\mu V$  on another part, it might change to 51  $\mu V$  p-p if you test it again, and that would be a fail of the test. So, your testing must be done with good repeatability and low noise.

Is it realistic to try to meet an AQL of 0.01% on such a test? Is it reasonable? Is that what you want to pay for? Would an AQL of 0.2% be just as reasonable? Let’s look at another spec. The OP-07A is guaranteed for 0.60  $\mu V$  p-p of noise voltage, max, in a bandwidth of 0.1 Hz to 10 Hz. When you test an amplifier for noise in a fairly small bandwidth like that, you must not expect to get exactly repeatable results. So if you measure 0.42  $\mu V$  one time and 0.48  $\mu V$  another time, you have to be very careful about the repeatability. If there is much *noise*, the guard-bands must get bigger and bigger until the spec is a LOT more conservative than what you’re actually measuring. As it is, the OP-07s have 0.35  $\mu V$  p-p typical, yet we’re barely able to guarantee 0.6  $\mu V$  p-p.

What if we said that this spec was only guaranteed at an AQL of 0.5%? Could we then guarantee 0.45  $\mu V$  p-p? Would you prefer to buy that as a spec? Would that part be of any significantly lower “quality” than the one with 0.60  $\mu V$  max? I myself would sooner buy the part with the looser (0.5%) AQL and the tighter spec, as I think it is a more realistic kind of spec with more realistic testing. The yield to the manufacturer might be better, the testing might cost less, and the actual noise performance might be better. What do *you* think? Comments invited.

At one time, one of the major suppliers of precision analog parts used to guarantee reference ICs with a certain long-term stability. In the fine print, they said that 90% of their production would meet that spec, even though they did not test for this. I dunno, but 90% seems a little rough as a quality level. Still, at times, that may be an *appropriate* quality level. But the company has stopped saying that....

Now, I will get into the MEAT of the topic. I recall reading the writings of such people as W. Edwards Deming,



**BOB PEASE**  
OBTAINED A  
BSEE FROM MIT  
IN 1961 AND IS  
STAFF  
SCIENTIST AT  
NATIONAL  
SEMICONDUCT-  
OR CORP.,  
SANTA CLARA,  
CALIF.

## PEASE PORRIDGE

Genichi Taguchi, and several other promoters of "quality." They argued that we should not rely on testing for high quality. We should not be trying to "test high quality" into our products, but instead we should build them with such high quality that testing is superfluous. That's what Mr. Deming said, and he was considered "the dean of the quality movement." When I first started writing this column in August of 1993, Mr. Deming was very much alive and kicking, and I was hoping to start a dialog with this feisty old-timer. However, Mr. Deming unfortunately died on December 20, 1993, and I'm disappointed that I cannot duel with him verbally. Still, maybe some of Mr. Deming's colleagues will be in a mood to hold up his end of the arguments, or explain what Mr. Deming thought.

NOW, Mr. Deming's philosophy seemed to say to the entire semiconductor industry: "Do not rely on testing. Just build everything perfect." Well, when we build good op amps, we may get a yield of 80 or 90 or maybe 93% at "wafer-sort," when we probe and test the chips on the wafer. We ink any dice that fail any test, and lots of good dice remain. After we assemble all of the good dice, we test the packaged circuits *again*, repeating many of the tests to weed out anything that may have gone sour, or worsened after assembly, or that may run poorly at a hot or cold temperature. Now we have a yield loss of only 1 or 2 or 3% at this "classification test" after assembly. Still, this is *infinitely* far away from Mr. Deming's philosophy. Why are we semiconductor manufacturers so thick-headed? Why can't we get anything right? Hmmmmm.

If you buy LM324 quad op amps in moderate volume from NSC, you pay about 38 cents and you get 4 good op amps with a quality level of about 99.9996% per package (about 1-ppm reject rate per amplifier). That may not be the best op-amp you can buy, but it's pretty darned good at the price. And I claim that it's the testing that makes these amplifiers so good. If you looked in our "scrap pile," you would find some amplifiers that literally meet the published spec—but we have installed tests to make sure

they're rejected. Hey, we reserve the right to reject op amps even though they meet the published specs, because we determined that there's something not quite right about them. Do we get this excellent quality by doing *no* test, or *minimum* testing? *Hell no.*

Ten years ago, we were shipping some of the highest-quality amplifiers in the industry, with an AQL perhaps 99.92%. Pretty good in its day. But we're doing better now—by a factor of 100 or 200. WHY? Because we have better tests. If you took some 1984 op amps and ran them through our 1994 testers, we might pass some that we failed before—because our tests are better. And we would surely fail some that were passed back in 1984—because our testing is better.

Over the past few months, I've asked several friends who work in Quality functions, test engineering, etc., and looked around myself trying to find out the answer to these questions: If the whole semiconductor industry is acting in contradiction to the "no testing" philosophy, has anybody made statements specifically rebutting it? And, has anybody explained that Deming's advice *does not apply* to the semiconductor industry.

As of yet, I haven't found anyone who has ever heard this stated. SO, you're going to hear it right HERE for the first time: There may be many kinds of manufacturing where testing to achieve high quality is the wrong way to do it. But in the semiconductor manufacturing business, testing is *EXACTLY* the right thing to do to get high quality.

NOW, I will not say that testing is exactly the *cause* of the good quality. We design these circuits to be of very high quality, very manufacturable. Our wafer fab usually has excellent quality, so these ICs usually do work well with high yields. But if a run has fewer parts than normal that meet all specs, we don't let that affect the quality of the parts we ship. We do our testing, and the test results tell us what's causing us yield loss.

When we go back to solve a basic design or manufacturing problem that hurts the yield, that may also help the real quality, too. Yet I claim that it's

the testing that drives the quality. What kind of IC, or car for that matter, would you buy if you were assured it was so good that no testing was needed?? How would the manufacturer know that the quality really was very good if he did not do tests?

If a Taguchi expert told you how to change your design, but decided not to check his results because his engineering was of such high quality that he didn't have to do any checking, would you buy *that*? NOTE—almost all of our customers are now accepting our testing as quite adequate. So when they buy circuits from us, they do not have to retest them for conformance to the guaranteed specifications at their "incoming inspection." That seems reasonable.

But of course when the customer assembles 22 or 46 or 79 components onto a board, then it's time to do some more testing for that assembly. I recently heard several friends complain about the poor quality of some electronic stuff they bought recently—some made in the U.S.A., and some imported, too. Right out of the box, the equipment failed to work, and you could *tell* that it had never been tested. Are you readers seeing that, too? Are some manufacturers starting to take "no testing" literally? If they talked themselves out of final test, a final *functional test*, that's pretty scary...

I had a talk with Melodie McClenon, manager of our Data Acquisition Test Engineering group. She agreed that we do find it important, occasionally, to add tests. They're necessary to screen out the few parts with bad quality which customers occasionally reject and gripe about. Often, a test is added to guard retroactively against some kind of a "Quality Accident," where a customer finds quite a few parts out of spec. Later, some manager may propose to delete that test as "superfluous." Melodie says she sometimes has to fight like heck to keep the test in, and she can usually do this by proving that the test, while usually unnecessary, is keeping a 1-ppm failure rate from being shipped.

I agreed that, if on most days, the test takes a few milliseconds, and cuts out a 1-ppm reject mode from being

## PEASE PORRIDGE

shipped, and it's ALSO able to help avoid the possibility of some disastrous bad parts from being shipped on 1 day out of 1000, that sounded like good judgment to me. I told her that I was on her side, and if she needed anybody to help her, I would fight like hell for her. It's always good to find a friend with ideas worth fighting for.

I have heard some guys argue that we should improve the yield of our op amps to 100%. I'm skeptical of that idea. At present, we have optimized for the lowest total cost for a good die, including the cost of testing. If we try to optimize the yield, with special wide spacings, special coatings, special processes, special redundant circuits, and so on, we might get a much higher percentage of good dice. But there would be fewer good dice per wafer—and fewer per dollar. Would these fewer dice be of higher quality? Higher reliability? How much better? And, if they are a little better, how much extra would you like to pay for them? Would you like to buy some with no testing? Just think about all of the money you would save by cutting out the testing....

Other people have argued that it's bad to have a low yield, because the quality must be bad. Nobody would want to buy an IC made with a yield worse than 50%, right? Well, almost every computer in the world has a processor chip that came out of fab with a wafer-sort yield much lower than 50%. That low a yield would sound pretty dumb for an op amp or gate or counter. But for a big processor, a yield of 10 or 20 or 30 or 40% may be quite rational, and very reasonable compared to making smaller dice with higher yield. It certainly doesn't mean that the dice which pass all tests are of poor or marginal quality. So far, we're doing exactly what Mr. Deming says not to do—yet our quality and reliability keep getting better, and cheaper. And everybody in the Semiconductor industry is doing the same.

One engineer pointed out that to plan to ship a part with the "correct" amount of quality, one might want to know if the intent is to ship a "Yugo," or a "Rolls Royce," or perhaps a "Honda Civic." If we wanted to sell the LM324 as the Yugo of the industry,

we could surely increase the yield by shipping parts that just met every published spec—but that might be wrong. The LM324 may have a Yugo level of specs, but we want to make sure it's tested out to a high grade of quality, a "Honda" grade of quality and reliability. Therefore, when you buy one, it comes with some *awfully good* quality. Do you know anybody who actually builds in worse quality on cheaper parts? Our customers, such as H-P, Delco, or IBM, would never stand for that....

Recently, I was surprised to learn that most of the early NSC linear ICs did not have any protective coating of Vapox or Nitride over the die. So, 24 years ago, LM108AHs came with a metal wire just flying through the air above the die, above the aluminum metallization, with no Vapox passivation over the die.

Were those old LM108s and LM101As less reliable than what we make these days? Maybe. But they have shown us a lot of proven reliability. Are new LM308ANs in epoxy mini-DIP packages less reliable than dice in hermetic packages? Well, the new mini-dip ICs are all lead-bonded with automatic machines, with much less variability and better repeatability than the old human-controlled lead-bonders. These ICs are ALL awfully reliable nowadays, and have excellent quality.

(Note, technically we must avoid confusing *reliability* with *quality*. Yes, a part that fails after a customer puts it to work can make the customer just as unhappy as a part that never met spec in the first place. But we have to treat those two problems *separately*. We want to provide parts with excellent quality *and* excellent reliability, and we have to be careful not to hurt one while helping the other. For example, if we do a burn-in test, we must make sure it doesn't harm a part's reliability.)

Now, a great majority of what Mr. Deming said makes excellent sense to me, and I'm pleased to recommend his ideas as an excellent legacy of his career. He observed, for example, that when making cars or airplanes or lawn mowers where the quality is randomly poor, and you're forced to go

back and rebuild or replace the engine or the transmission (or the paint) before you can ship the product, it's a LOUSY way to do business.

So, do any readers have any opinions on testing? Have you seen anybody else's good convincing statements or arguments on this topic? I'd love to hear from you. I do know that NSC has always done some testing on every component they shipped, and it's unlikely that we'll change that statement. In fact, *more* testing usually helps provide higher quality, compared to *less* testing.

As a final note, I sent an early letter on this topic to Mr. Deming at his home. He did not reply at that time, but it's not possible to draw any conclusions from that. I just wish I had been able to find a good excuse to talk to him earlier!

All for now. / Comments invited!  
RAP / Robert A. Pease / Engineer

Address:  
Mail Stop D2597A  
National Semiconductor  
P.O. Box 58090  
Santa Clara, CA 95052-8090

### BOB'S MAILBOX

#### Dear Bob:

Perhaps 30 years ago at a national IEEE conference dinner in L.A., the speaker was introduced as Dr. \_\_\_\_\_, Chairman of the Department of Electrical Engineering at \_\_\_\_\_ University. He graciously thanked his host for conferring upon him the degree of Doctor, and then told the dumb-founded audience of IEEE members that his formal education ended with high school!

Apparently we're not alone in giving both recognition and our trust to non-degreed personnel who, as Peter Scargill wrote in the Sept. 16, 1993 Bob's Mailbox, "have dedication, clear thinking, and more dedication."

**ED OXNER**

**InterFET Corp.**

**Manchaca Texas**

*When a guy has good talents, we ought to appreciate them without any prejudice about his race, religion, origin—or schooling.—RAP*



## PEASE PORRIDGE



# BOB'S MAILBOX

### Dear Bob:

I have as usual just read with pleasure your Dec. 16, 1993 article concerning "Floobydust Stuff." The antics to produce a floating scope took me back once again to the mid 50's when I was involved in modifying your N.T.S.C. system to the British 405 line system. My particular project was to produce a line timebase using only components available over here. The scan coils were at a boost voltage of approximately 800 V, and the only way to see the scan current was to float a Tektronix 524AD on a large cardboard box and hope that no one touched it. This wasn't the only hazard, E.H.T. was regulated by a shunt triode valve which produced copious amounts of X-rays, but a prominently displayed Geiger counter deterred all but the most indomitable visitors.

However, time moves on and my company now produces an "isolation amplifier" which will enable you and your friends to make measurements on floating circuits without the attendant risks to life or limb, or the purchase of yet another scope.

**PETER WAUGH**  
*Waugh Instruments Ltd.*  
*United Kingdom*

*I rarely use more than 60 V, but when I do, I use an NE-2 neon lamp to remind me I'm not in 5-V and anymore. (I bet that Tek 524AD would have needed a lot of silk threads to support it.)—RAP*

### Dear Bob:

Just returned from Christmas holiday to find your Pease Porridge column in the Dec. 16, 1993 issue (definitely cold and more than 9 days old) discussing Reverse Pulse Charging of batteries. Christie Electric Corp. has been implementing this process in various products for more than two decades as REFLEX chargers.

The implementation of a discharge pulse interspersed between charge pulses has proven particularly effective with Nickel-Cadmium batteries

(an alkaline chemistry cell). Some advantage can be gained with Lead-Acid batteries, and other chemistries such as Nickel-Metal Hydride. The optimum pulse algorithm varies depending on cell construction and chemistry.

Waaay back (late sixties, I think) there was a brief, very brief, introduction of a supposedly rechargeable manganese alkaline cell type. It disappeared quickly.

I may work up the nerve to try some "primary" alkaline cells with our equipment if I can get an adequately explosion-proof containment chamber first. I have seen even rechargeable Ni-Cd batteries explode (it's called "thermal runaway"), so the thought of pumping up a non-rechargeable cell should be carefully considered and controlled.

**BILL MONAGLE**  
*Christie Electric Corp.*  
*Gardena, Calif.*

*I had no troubles with explosion or corrosion when I charged my alkalines, they just didn't hold any charge. I'm trying the Buddy L "Super-charger" next.—RAP*

### Dear Bob:

Now that I have a Camcorder myself, I am a bit more interested in what you have had to say about batteries and recharging. I have two questions for you on this topic. First, does anyone make NiMH batteries for camcorders yet? It seems like these would be better, and camcorder batteries are becoming more standardized. And second, why not use some sort of solar panel to charge your camcorder batteries (or replace them altogether), which could also shade your head while you hike around? Seems like that would be a good thing for Real Goods to offer.

I also enjoy your comments on Dr. Science. They don't carry him on any local stations, so I have to order the cassettes and books from Duck Breath, but that's OK. In a rather shallow attempt to avoid copyright

problems, I have been working on a "Mr. Science" session for Mensa gatherings. My intention is to replace their Joke Off with my Mr. Science, since we have all heard all the jokes anyway. But unlike Dr. Science, what I am proposing is a chance for participants to tell preposterous tall tales of science outright, without the initial question. This may work at meetings of other groups as well. And it may end up being a bit like a verbal *Journal of Irreproducible Results*. I have been working on an imaginary news story about how banks are funding wormhole research, so their customers can have access to their safe deposit boxes from any branch of the bank...

It seems to me that people just don't have enough opportunities to laugh anymore. I don't know why that is, but many others agree that life has just gotten too damned serious. Within Mensa, I started a Creative Mischief SIG to help counter this. It has become quite successful, and caused many people to laugh. It also makes people read posted signs very carefully, since we tend to create hoaxes that are in the form of posted signs. Our fake ads for an imaginary "Schroedinger's Cat Sitting Service" is a hit, and almost believed by a number of people.

So, I look forward to the April 1 issue of Electronic Design and your column. Keep up the great work, and go ahead and double-clutch that VW.

**MARK S. HUTCHENREUTHER**  
*Oxnard, Calif.*

*I find that NiMH has only 15% more watt-hours per ounce than NiCds. But they are more dense, and pack 40% more watt-hours in a given volume. That's not a big deal when I back-pack. I don't like to depend on just solar cells on cloudy days.—RAP*

## More Floobydust 1993 ....

As I mentioned a couple of months ago, "floobydust" is a *recently-coined* (1976) term for "miscellaneous." Some

## EXCESS INVENTORY IS CHANGING HIS LIFE



Anthoine has the chance to break the vicious cycle of poverty which strangles his neighborhood. Up until now his best "career" opportunity would be gangs and drugs.

That was before EAL.

Even though he's still in 8th grade, Anthoine knows there's a college scholarship waiting for him. EAL's "Excess Inventory for Scholarships" program is giving him the hope and incentive he needs to finish high school.

If your company has excess inventory, you can change a life by donating it to EAL.

For More Details  
Call 708-690-0010  
Peter Roskam  
Executive Director



**EAL**  
Educational Assistance Ltd.,  
P.O. Box 3021  
GLEN ELLYN, ILLINOIS 60138

## PEASE PORRIDGE

people don't consider 1976 as recent, but I usually do.

- I got several letters from readers pointing out that Whirlpool's high-efficiency refrigerator only uses Fuzzy Logic to plan the schedule for Defrosting, avoiding the wasted energy of Defrosting when no Defrost is needed. This provides a 3% advantage over a dumb fixed-cycle defroster. That sounds pretty reasonable.

But Mr. R. Shattuck of Gillett, Pa. pointed out that it is a well-known trick among refrigerator engineers, to disconnect the Defrost timer from line power (which provides a fixed 12-hour Defrost spacing), and reconnect it to the switched power fed from the thermostat to the compressor. This way, when the door is opened a lot, or when it is a hot humid day, the Defrost cycle will run more often, and when it is a cool day, or the door is not opened much, the defrost cycle will occur less often. It is unclear how much advantage the Fuzzy Logic provides, compared to this simple but thoughtful scheme.

Note: Whirlpool is delighted to say that its prize-winning refrigerator is 29% more efficient than the 1993 Federal Efficiency Guidelines. However, it is fair to point out that this basic refrigerator was 20% more efficient than the 1993 Efficiency Guidelines, even last year, *before* they started to optimize it for the competition. So, *you* figure out, what is a Straw Man, and what is not....

- A knowledgeable spokesman for BART (Bay Area Rapid Transit) confirmed that BART trains accelerate and decelerate and run smoothly, *without* the use of Fuzzy Logic. More on this, later.

- Recently I was invited to lecture on Fuzzy Logic, with the Santa Clara Valley IEEE Measurement and Instrumentation Society. I asked the throng of 120-odd people, has anybody ever *actually* stabilized a triple inverted pendulum, using Fuzzy Logic? Or was it just *simulated*? A couple people confirmed that it was only simulated... sigh....

- As I mentioned in December—I once paid \$30 for the charger station for Ray-O-Vac *Renewal* rechargeable alkaline batteries—but recently I noticed the price was now \$49.95, at the

same store where I bought mine....

- I finally did get some literature on the Ray-O-Vac *Renewal* rechargeable alkaline batteries. Their capacity does not shrink very rapidly with use—it is still 60% of the original capacity, after 25 cycles. However, a *Renewal* D cell is rated for just 5.5 ampere-hours when new (@ 2.7 ohms load). I was really expecting more. A conventional alkaline D cell has 14.2 ampere-hours (@ 4.7 ohms load), even though you can only use it once.

- It is true that *most* NiCd D cells, as available at popular electronics and consumer stores, pack only 1.6 ampere-hours, because most NiCd D cells are built with only a C cell inside—rather cheap and light in weight. But you can buy real D cells that pack 4+ ampere-hours, if you ask for high-capacity NiCd cells—available at Radio Shack, DigiKey, and other good electronics stores. About \$18 per pair, and well worth it if you really need the energy.

- Has anybody noticed that you can no longer buy an inexpensive \$10 1/4 inch electric drill? All the stores want to sell you is a fancy reversing variable-speed 3/8 inch drill, or a \$50 cordless drill, or a \$129 "professional grade drill." From coast to coast—what kind of conspiracy is going on? Or, can anybody tell me where I can buy a 1/4 inch drill? If they are going to become collector's items, I'll buy three. Maybe other readers would like to be able to buy one, too.

- Recently an engineer who lives in Europe pointed out that I was not very helpful if I only list 800-989-DUCK as the number for Doctor Science, because it is impossible to call an 800 number from outside the USA. So for example, if somebody wants a catalog of Doctor Science's wit and wisdom, the real telephone number, that anybody anywhere can use, is 916-265-5470. You should always list a *real* number with the 800 number.

All for now. / Comments invited!  
RAP / Robert A. Pease / Engineer

Address:  
Mail Stop D2597A  
National Semiconductor  
P.O. Box 58090  
Santa Clara, CA 95052-8090

# WHAT'S ALL THIS TECHNICAL READING STUFF, ANYHOW?

**R**ecently a young engineer, Barrett L. of Poughkeepsie N.Y., wrote me a letter. He not only ordered one of my books, but he asked my advice and opinion: "I'm a recent E.E. graduate, and if you could please supply me with a list of suggested reading (i.e. books, periodicals, columns) it would be greatly appreciated." Well, I *had* to reply:

"Dear Mr. L.—Darn it, you are the second person this week to ask me this question, and while I was stupid enough not to get the message the first time, I won't miss the message twice. Fortunately, there are several good books I can recommend.



**BOB PEASE**  
OBTAINED A  
BSEE FROM MIT  
IN 1961 AND IS  
STAFF  
SCIENTIST AT  
NATIONAL  
SEMICONDUCTOR  
CORP.,  
SANTA CLARA,  
CALIF.

Fortunately, there are several good books I can recommend.

You have not gone wrong in ordering my book on *Troubleshooting Analog Circuits*.<sup>1</sup> I try to keep things light and breezy, with REAL examples. And I also try to minimize the platitudes, as you have noted that nothing gets me TICKED OFF faster than meaningless platitudes. I think real engineers get their education from

EXAMPLES, and I try to write accordingly.

A second related book, from the same publishers, is *Analog Circuit Design*,<sup>2</sup> edited by Jim Williams. It consists of about 33 chapters from 23 authors. It, too, is educational in terms

of EXAMPLES. Some of the chapters are so-so (in my opinion) and then they get better and better, up to *great*. The chapters by John Addis and Derek Bowers are great. I wrote two good chapters.

NOW, if you laid hands on this book you might decide that you wanted to buy it, OR you might read a few chapters and then put it back on the shelf. So get your librarian—your town librarian or your company librarian—to order it. If you ain't on good terms with your librarian, you *should be*. After the librarian buys it, it can be shared by a good number of people.

Nextly, there's Horowitz and Hill's *The Art of Electronics*.<sup>3</sup> Any bookstore will order it for you. It's in its second edition—very popular, fun to read, good insights. Your company librarian would be wise to buy this one if there are more than six engineers in your company. Maybe you have read this already. It's a good reference book. If there are older engineers who went through school before this book came out, or technicians, they may find this of high value.

At this point, I gotta ask you, Barrett, where are you *coming from*? What good electronics books have you read? Did you take a lot of electronics courses? How many analog, how many digital, how many software? I can assure you, I can give you ZERO advice on software. I have written a couple of successful chunks of BASIC, but my opinions are worthless. I can't give you much advice on digital circuits, and books thereon, but I'll ask my friends.

Next question for you—in which direction do you think you are *going*? Analog, ADCs, or systems? Low power? High speed? Lotsa processors

and a little analog? Just trying to get a broader education? That will make some difference. Or, if you're not sure where you're headed, well, the broad perception from reading a lot will be good for you.

OF COURSE you gotta keep reading *Electronic Design*.<sup>4</sup> It gives you a good clear presentation of some of the newer ideas, circuits, concepts, and trends, with intelligent guys from the industry trying to make good explanations—trying to play teacher. One item of advice: Read and mark the hell out of any stories that are interesting. Xerox or cross-index the stories that are of good interest, but don't throw the magazines away for at least five years. You can go back in several years and see what's interesting, what's trivial, and what's passé. Note, a five-year stack of ED just fills two "Xerox-paper boxes," about 2.5 cubic feet....

Read hobby magazines —*Popular Electronics*<sup>5</sup> or similar publications. Some of the stuff is trivial, but that's OK—sometimes it's good to read stuff where you're smarter than the authors, and you can see if they're doing something stupid.

James Roberge of MIT wrote an excellent book about op amps in general, and about the LM301A in particular.<sup>6</sup> The first half explains how the '301 chip was engineered; the second half goes into how you can *apply* a '301. I asked James and he said it's still in print. It's a very good read.

The advanced, expert book on op amps is by Jiri Dostal—*Operational Amplifiers (second edition)*.<sup>7</sup> I'm selling these for \$53. This used to sell for \$113 from Elsevier Scientific, and was worth it. Now at \$53, it's a bargain. Serious, thoughtful. NOT your FIRST primer on op amps, but any serious user of op amps should read this about once a year. You'll learn something new every time. However, that statement is true for almost every one of these books: All of these books are well worth rereading every year or two.

Now, darn near your first primer on op amps is Tom Frederiksen's *Intuitive IC Op Amps*.<sup>8</sup> Heck of a fine book. Where is it sold? Tom still has some to



## PEASE PORRIDGE

sell. If you want to use op amps, you want to do it intuitively. No fancy formulae, no matrices, no Taguchi optimization. Just common-sense engineering with good intuitive insights. Tom's an excellent teacher for that.

The NEXT primer on op amps is NSC's linear databook on op amps.<sup>9</sup> The history of op amps was written there.

NOW, Analog Devices' op-amp databook might be almost as good as NSC's, *but* they usually don't include device schematics. If you want an AD databook, call them up.<sup>10</sup> You can request and study databooks from anybody in the whole electronics industry, but I find the ones that do include schematic diagrams (of the devices themselves) are the most useful and educational.

NEXT, NSC's *Linear Applications Handbook*.<sup>11</sup> Some of the better early linear IC applications breakthroughs have gone into there. It's indexed pretty well, so you can find what you want.

NSC's databook on regulators and power ICs<sup>12</sup> is quite good—a useful basic reference book. Also falling into that category is the *Data Acquisition Databook*<sup>13</sup>, which covers DACs, ADCs, voltage references, and temperature sensors. Another is the *Linear Applications-Specific ICs Databook*,<sup>14</sup> which includes several strange but useful ICs.

The list price for these NSC handbooks is usually about \$10 or \$15 *each*. But our marketing guys agreed that we ought to make a special offer to readers of *Electronic Design*—serious engineers. If you want any or all five of those linear databooks, just call and ask for the set.<sup>15</sup> Not a bad deal.

If you ever have to do "optimization" or quality problem-solving, buy the books that cite "Taguchi" in them the *fewest* number of times. I just got around to reading Keki Bhote's book<sup>16</sup>, full of excellent common sense. I started out skeptical, but eventually decided I really liked his style and common-sense approaches. Hans Bacteria has a good book.<sup>17</sup> So does Forrest Breyfogle.<sup>18</sup> And Diamond's book<sup>19</sup> is good, too. Just keep away from books by Genichi Taguchi, and all his friends who tell you how great it is

to use orthogonal matrices to solve any problem and you don't have to think... (if you know what I mean, and I think you do).

Recently, I was introduced to a new book by Dennis Feucht, *Handbook of Analog Circuit Design*.<sup>20</sup> It really covers lots of the things a designer needs to know about analog circuits. I'm favorably impressed, and I recommend it. It has good chapters on wide-band amplification, precision amplification, feedback circuits, frequency compensation, signal-processing circuits, etc. There's some overlap with Hill and Horowitz, but that's *good*, not bad.

Another good new book is *High-speed Digital Design*, by Howard Johnson, subtitled *A Handbook of Black Magic*.<sup>21</sup> I thought it was pretty good, so I loaned this to one of our best digital/mixed-signal designers. I was a little surprised when he returned it right away. He said that was because he had gone out and bought several copies for the guys in his group. It treats the gray area between signals that are digital, and the analog aspects that are so important when you want your digital buses to behave at higher and higher speeds—not a trivial task. This book is there to help, with serious advice and good philosophy. You ain't gonna get much of that anywhere else these days.

One of my old fans, Reg Neale, recommended a book on ESD, *ESD from A to Z*, by John Kolyer.<sup>22</sup> I discovered the book in our library, read through it, and found a number of thoughtful observations. Just as my book is the "best" book on Troubleshooting, so this book may well be the "best" on ESD, and *partly* for the same reason—it's the only one.

When I wrote about Ground Noise in June, I recommended the excellent book by John Barnes, *Electronic System Design*,<sup>23</sup> and I still do. Also, a friend recommended *Noise Reduction Techniques in Electronic Systems*, by Henry Ott.<sup>24</sup> Its second edition just came out, and it, too, covers many topics that aren't taught in schools. If you work with RFI and EMI in real systems, you'll probably profit by buying and reading *both* of these books.

Recently, Barrett, a reader asked me what book can I recommend to teach about designing printed-circuit boards? I asked several friends—no ideas, no recommendation. Maybe some of our readers can recommend a book? There *ought* to be something beyond the literature of the pc-board-design software people...

Also, you and other readers who recall the question and debate of the value of a Bachelor's Degree versus an Associate's Degree in Electronics Technology may be interested in a new book by Joel Butler, *High-Tech-ology Degree Alternatives*.<sup>25</sup> He observes that you don't have to go to school at night for a dozen years, nor drop out of work and pay tuition for four years. He has several suggestions on how you can get credit for school courses and work you have already accomplished. He recommends a list of a few dozen schools where you can apply by mail. This sounds kind of unlikely, except Mr. Butler points out that these schools actually are ACCREDITED, which isn't a trivial statement.

One last "book," actually some stories on floppies, was sent to me by Geoff Harries, a reader located in Munich, Germany. They are Science Fiction, sort of high-tech and time-travel, and good historical stuff, too. He's still trying to get a publisher. Meanwhile he gave me permission to sell you his book, *ChronDisp I* (about 700 kbytes) on a high-density IBM-type floppy for about the same price as a paperback book. I will repatriate all proceeds to Geoff. I enjoyed the book, and I recommend it to you, too. It's kind of fun to sit there in the evening, hitting "Page Down," again and again, reading Geoff's stories.<sup>26</sup>

Well, there is my list. This may not be a DEFINITIVE list, but it's a good start. Ask your buddies. Borrow some of their hobby magazines. Also, you will probably want to read one or two general-purpose science magazines. I used to read *Scientific American*,<sup>27</sup> but a year ago I gave up on them and changed over to *Discover*.<sup>28</sup> Maybe *Sci Am* is coming back, but I still think *Discover* is excellent. Try *Machine Design*.<sup>29</sup> You can spend a lot of time reading this, but it's fun and educa-

## PEASE PORRIDGE

tional. You'll see several kinds of good engineering.

Ah—yes, let's not overlook the obvious. You should also read *your own company's* catalog or data sheets. Look at what it says to your customers, and look at the circuits "behind the front panel." I don't know what your company does or makes, but let's assume there are PRODUCTS somewhere. When I joined Philbrick in '61, I studied the heck out of all its schematics and data sheets, op amps, and analog computing products. Then I would say to myself, "Why did they do that?" I surely couldn't understand everything, but by asking all questions that came to mind, I got a *heck* of an education.

Similarly, when I came to NSC in 1976, I studied all of the op amps, data sheets, schematics, AND layouts. I'm sure you will agree that in an IC, the layout can be even more important than the schematic. In my first year at NSC, I spotted a philosophical error in the layout of a popular amplifier. The changes I suggested caused the yield to go up on the LF356, the LF256, AND the LF156, by a factor of 2, EACH. That yield improvement paid for my first couple years' salary, even if I had done nothing else.... So, read your own company's literature, and the serious art (schematics, layout, software, or whatever) that's behind the scenes.

NOW you can plainly see that I have written a whole *column* around your request, for pity's sake! I hope I have answered the question for you *and* for many other guys who are just out of school and trying to get going—up the LEARNING CURVE. So, read books and think of good questions. When you have answered as many as you can, and you have asked your colleagues, and there are still some you cannot answer, write down some notes and ask one of your Senior Engineers. He'll probably be flattered to get thoughtful questions from a *serious* student. If you ask reasonably, he/she may provide some (priceless) mentoring. Have fun, Barrett!!"

All for now. / Comments invited!  
RAP / Robert A. Pease / Engineer

Address:  
Mail Stop D2597A  
National Semiconductor  
P.O. Box 58090  
Santa Clara, CA 95052-8090

1. *Troubleshooting Analog Circuits*, 3rd Printing, Robert A. Pease, 1992, 208 pages. Butterworth-Heinemann. Order from Robert Pease, 682 Miramar Ave., San Francisco, CA 94112. NOW in PAPERBACK—NEW LOW PRICE—\$25.95 including tax & shipping.

2. *Analog Circuit Design: Art, Science, and Personalities*, edited by Jim Williams, 1992, 222 pages. Order from Robert Pease, (see address in reference 1) \$47.95 includes tax & shipping; or order it from the publishers, Butterworth-Heinemann, Stoneham, MA; (800) 366-2665 or (617) 438-8464.

3. *The Art of Electronics* (2nd Edition), Paul Horowitz and Winfield Hill, 1989, 800 pages. About \$60. Cambridge University Press, NY; (914) 937-9600 or (800) 872-7423. In NY, (800) 227-0247.

4. *Electronic Design*, Penton Publishing. To apply for a free subscription, write to Electronic Design, Reader Service Dept., 1100 Superior Ave., Cleveland, Ohio 44197-8132.

5. *Popular Electronics*, about \$19 per year. Call (800) 827-0383 or (516) 293-3000.

6. *Operational Amplifiers: Theory and Practice*, James Roberge, 1975, 678 pages. About \$71. Wiley/Krieger. Call (407) 724-9542.

7. *Operational Amplifiers (Second Edition)*, Jiri Dostal, 1993, 555 pages. Butterworth-Heinemann, Stoneham, MA. Available from Robert Pease for \$53, including tax & shipping. (see address in reference 1)

8. *Intuitive IC Op Amps*, Thomas M. Frederiksen, McGraw-Hill, 1988, 352 pages. Order from Thomas Frederiksen, 24705 Spanish Oaks, Los Gatos, CA 95030; \$25.00 including tax & shipping.

9. *Operational Amplifiers Databook*, National Semiconductor Corp., 1993. Publication No. 400061.

10. Analog Devices Inc., Literature Dept. (617) 461-3392.

11. *Linear Applications Handbook*, National Semiconductor Corp., 1994.

Publication No. 400043.

12. *Power ICs Databook*, NSC 1993. Publication No. 400062.

13. *Data Acquisition Databook*, NSC, 1993. Publication No. 400033.

14. *Linear Application-Specific ICs Databook*, NSC 1993. Publication No. 400060.

15. Set of 5 NSC linear databooks—items 9, 11, 12, 13, and 14 above—call the NSC Customer Response Center, (800) 272-9959 or (817) 468-6811.

16. *World Class Quality: Using Design of Experiments to Make It Happen*, Keki R. Bhole, AMACOM, 135 W. 50th St. NY, NY 10020; (518) 891-5510 About \$25.

17. *Statistical Problem Solving—A Team Process for Identifying and Resolving Problems*, Hans Bajarria & Richard Copp, 1991, 300 pages. About \$45. Multifac Publishing Co., Garden City, MI; (313) 421-6330.

18. *Statistical Methods for Testing, Development, and Manufacturing*, Forrest Breyfogle, John Wiley & Sons, 1992; (908) 469-4400. About \$65.

19. *Practical Experiment Designs for Engineers and Scientists*, William Diamond, 1981, 347 pages. Van Nostrand Reinhold, NY. About \$55. Call (800) 842-3636 or (606) 525-6600.

20. *Handbook of Analog Circuit Design*, Dennis L. Feucht, 1990, 685 pages. About \$65. Academic Press/Harcourt Brace Jovanovich, San Diego, CA; (800) 782-4479 or (407) 345-2500.

21. *High-speed Digital Design (A Handbook of Black Magic)*, Howard Johnson and Martin Graham, 1993. About \$47. PTR Prentice-Hall, Englewood Cliffs, NJ; (206) 556-0800.

22. *ESD from A to Z*, John Kolyer and Donald E. Watson, 1990, Van Nostrand Reinhold, NY; (800) 842-3636 or (606) 525-6600. About \$47.

23. *Electronic System Design: Interference and Noise-Control Techniques*, John R. Barnes, 1987, 144 pages. About \$48. Prentice-Hall, NY; (800) 947-7700 (out of print).

24. *Noise Reduction Techniques in Electronic Systems*, (2nd edition), Henry Ott, 1988, 426 pages. About \$65. John Wiley & Sons, NY; (908) 469-4400.

25. *High-Technology Degree Alternatives*, Joel Butler, 1994, Professional

## CLASSIFIEDS

### SURPLUS INVENTORY

## SURPLUS SALE

### 200,000 WALL TRANSFORMERS

7.5 VDC	50 MA	0.85
12 VDC	100 MA	1.10
12 VDC	500 MA	1.75
12 VDC	800 MA	2.10
14 VAC	500 MA	1.75
16 VAC	1.25 A	2.95

Min 1000/type -- Call for other types

### SURPLUS TRADERS

PO Box 276,  
Alburg, Vt. 05440  
Tel: 514-739-9328  
Fax: 514-345-8303

**FREE CATALOG!**



### FAX YOUR ORDER!



To Advertise in Penton Classifieds



**FAX:**  
**(216) 696-8207**



Looking for

## "leading edge" engineers ?

# 165,090

Electronic Engineers  
and  
Engineering Managers  
read  
**ELECTRONIC  
DESIGN**  
twice monthly.

To reach them with a recruitment ad in this section call:

**Lois Walsh at  
Penton Classifieds  
(216) 696-7000  
ext. 2359  
FAX 216-696-8207**

## PEASE PORRIDGE

Publications, 1250 Fifth Ave., Belmont, CA 94002; (415) 593-9119. About \$22.

26. *ChronDisp I: The Gun From The Past*, Geoff Harries, 1993, Munich, Germany. Can be ordered on a high-density IBM-compatible floppy disk for \$4.00 (including tax & shipping) from Robert A. Pease, 682 Miramar Ave., San Francisco, CA 94112.

27. *Scientific American*, about \$36/year. Call (800) 333-1199 or (515) 247-7631.

28. *Discover*, Family Media, NY. About \$27/year. P.O. Box 420105, Palm Coast FL 32142; (800) 829-9132.

29. *Machine Design*, a Penton Publication. Write on letterhead to 1100 Superior Ave., Cleveland Ohio, 44114-2543.

### BOB'S MAILBOX

*Dear Mr. Pease:*

A couple of things for your checklist:

1) Samsonite and American Tourister suitcase keys. Every Samsonite key fits all Samsonite suitcases and it is the same with American Tourister. Most hotels are willing to provide a hammer and chisel to forgetful guests, but they haven't yet figured out that two keys will open 90% of all lockable suitcases. You get to be a good Samaritan more often than you'd expect.

2) An eyeglass repair kit.

3) A length of telephone cord with a plug adapter. The hotel gives you a table and chair, but they are usually across the room from the telephone.

4) A styptic pencil.

5) Shoelaces.

6) A small flashlight. I never carried one until lightning hit the transformer in front of a Holiday Inn where I was staying in Florida. They had to evacuate the place in the pitch dark. There was no emergency lighting and the management passed out matches. When you need a flashlight, you really need a flashlight.

7) Rubber bands, safety pins, cable ties, and Band-Aids.

**WALTER E. GATELY**  
*Medfield, Mass.*

*Sometimes a candle is as good as a flashlight—if it doesn't melt. Thanks for your excellent ideas.—RAP*

# The bus stops here.



Our new ML6509 doesn't just terminate the SCSI bus. It provides optimum V-I termination characteristics. With the lowest capacitance, guaranteed. And it supports a low power termination mode. All in a small form-factor TSSOP package.

- Unique MOSFET-based architecture provides optimum V-I characteristics.
- No external components are required for current sinking and negative clamping.
- Disconnect capacitance is guaranteed to be <math><5\text{pF}</math> through production test.
- Low power termination mode for power-conscious SCSI peripherals and notebook PCs result in 1/24th the power dissipation.
- Available in either 20-pin TSSOP or 16-pin SOIC packages.

For more information contact Ram Gopalan, Micro Linear Corporation, 2092 Concourse Drive, San Jose, CA 95131, (408) 433-5200 x352.

 **Micro Linear**





# BOB'S MAILBOX

**Dear Bob:**

I really enjoy your pokes at Taguchi and Fuzzy Logic. To further emphasize how out-of-touch our engineering academics have gotten, I offer the following paragraphs for one of your "Mailbox" columns:

"Your critiques of Taguchi Optimization and Fuzzy Logic have been a great service to us engineering practitioners. Do not, however, interpret the dearth of practical applications to mean that these technologies have been less than successful. To the contrary, Taguchi's exuberant lectures to technologically defenseless managers about the hypothetical success of some ill-founded analytic hocus-pocus have certainly succeeded in putting high-priced bread on his table. With similar success, academics armed with Fuzzy Logic have transformed simple, low-gain, well-understood servo loops into esoterica, thereby hoodwinking the taxpayers out of \$100K research grants.

More seriously, however, the failure of these promotions to produce the engineering efficiencies they tout points up a much more troubling problem than simple delusion. The academic community has become isolated from the engineering arts they profess to teach. I doubt that 1 in 50 American electrical-engineering professors could design a production-worthy product. They do not know what components and materials are available, what limitations and strengths these products have, what configurations and combinations are most practical, or what manufacturing efficiencies and problems their choices create. In short, all they know is mathematical analysis of idealized circuits—a very small part of the total design task.

Although they clearly lack the wisdom and knowledge essential for success in engineering, academics still wish the prestige of being considered industrial experts in the field their title professes. Just as medieval alche-

mists sought to concoct valuable gold from an incomplete understanding of chemistry, our modern university alchemists seek to concoct practical designs from an incomplete understanding of engineering. Having only analytic skills, the alchemists' naive and ill-targeted mathematical incantations serve as the modern mortar and pestle.

It is not that we don't appreciate the attempts of our monochromatic university brethren to shed light on the engineering process, it's just that we wish they would have more respect for the complexity of the total design problem."

There, Bob, now how's that for self-control and diplomacy?

**JAMES A. KUZZRALL, P.E.**

**President  
Intrel Service Co.  
Nashua, N.H.**

*James, I think that most EE professors can contribute good stuff to a project team—just as most engineers in industry can—even though they are not all good at running the whole project.—RAP*

**Good Morning Bob,**

...I don't think I ever told you about truck 2 (T2). I have encountered various mysteries in electronic equipment, usually small deviations from ideal behavior. I haven't solved every mystery, but usually I have a notion of the cause, such as nonlinearity, or noise or drift, or parasitic L, R, or C. But nothing that needed a magical explanation. That is, except good old T2.

I spent 1974 at McMurdo station, Antarctica. During the summer there are various trucks in the motor pool, but during the winter when there are only 3 permanent experiments, (riometers, cosmic ray counters, and satellite tracking) we had assigned trucks. My predecessors gave me a few tips (they laughed all the way to the plane), but they were most emphatic that I should insist on T2 during the winter.

That was good advice. I was able to start it even on the coldest days. I had

to do without T2 for awhile, because one morning when there were only two vehicles moving in the base (my partner in T2 and a fork lift), they tried to occupy the same space at the same time. But we had a good mechanic, an ex-linebacker from USC, who intimidated T2 back into service. This was really fortunate.

I got to McMurdo just before the base was isolated for the winter. When summer came again, about 7 months later, and T2 was back in the motor pool, the guy running the riometer (two dipole antennas that measure RF noise from the sky at various frequencies in the 2-to-40 MHz bands) had been there a full year. He convinced the folks in charge and me that I could look after the riometer for a week while he took R&R in New Zealand (nearest civilization with an airport). He never came back.

Well, the old riometer was automated with relays and RTL logic. Every few minutes it scanned the frequencies and recorded the levels in a multipoint recorder, which was a wondrous mechanical thing that could make marks on chart paper with about 12 different colors. When things worked fine, there would be 12 smoothly varying curves on the chart.

I soon found out that things worked fine for about 30 hours at a stretch. After that, the multipoint recorder started scattering colored marks all over the chart. I never found out what was wrong, because in the process of opening panels and disconnecting cables to get into the thing, it would start working.

It was frustrating. The riometer was away from the base behind a hill to cut down on RF noise coming from the base, so I had to drive a truck out there. Sometimes, the riometer would start working just as I drove up. I could tell by looking at the chart when it had stopped working right and when it started.

Then I noticed an amazing thing. Every time I drove up to the riometer

# PEASE PORRIDGE

in T2, it started working. No other truck had this effect. After verifying this, I finagled T2 once a day and drove up to the riometer. It worked fine for the rest of my tour. I never did reveal to anyone why I was so insistent on driving T2. Sometimes the bureaucrats wouldn't give me T2, but I

had a duplicate set of keys and just took it during the night.

There aren't many trucks that know how to make electronic equipment work. I suppose that T2 had really big ignition noise that somehow reset whatever was going nuts in the riometer, but magic is just as good an

explanation.

**ROY MCCAMMON**

**3M Test and Measurement Systems  
Austin, Texas**

*Roy, when you are troubleshooting an intermittent problem, an ability to chase away the problem is not necessarily more valuable than the ability to restart the trouble. Right?—RAP*

**Dear Bob:**

I just received the February 7 issue of Electronic Design, and read your column on the relevance of Deming's stand on inspection to the integrated circuit business. Deming has stated explicitly his view of inspection in this field. I quote from page 29 of his book "Out of the Crises," published in 1986 by MIT: "We must note that there are exceptions, circumstances in which mistakes and duds are inevitable but intolerable. An example is, I believe, manufacture of complicated integrated circuits. Separation of good ones from bad ones is the only way out. Calculations and other paperwork in a bank or an insurance company is another example. It is important to carry out inspection at the right point for minimum total cost."

**ARTHUR DAVIDSON**

**Senior Engineer  
Westinghouse STC  
Pittsburgh, Pa.**

*Mr. Deming's index said to look for "integrated circuits" on page 31. Those comments were not on page 31, but seem to have turned up later on page 29. Now, what is the explicit definition of a "complicated" IC? A quad op amp but not a 741? A dual flip-flop but not a quad gate? Would YOU like to buy op amps, gates, or transistors that have not been tested? Impossible—nobody will sell you one.—RAP*

## REUNION STUFF

All Alumni, Alumnae, and Survivors of (Teledyne) Philbrick Researches, plan for a Reunion at 5 P.M., April 20, at the Hilton Inn across from the Philbrick plant, Allied Dr., Dedham, Mass. For details, contact Cruise Director Joe LoSciuto, 510 Grove St., Norwell, MA 02061; (617) 659-4423. If you can't attend, send a letter to Joe. Keep the faith!—RAP

## New 20-Bit D/A Converter Features Ultra-Low -96dB Max THD+N

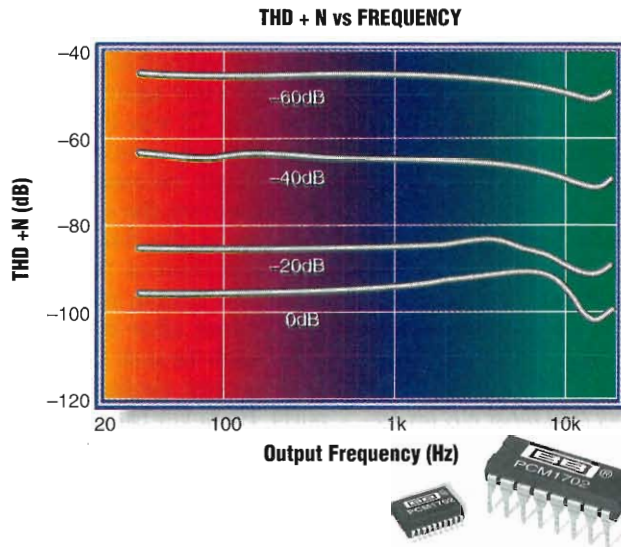

PCM1702 is the hottest new professional audio DAC on the market! Its unique advanced sign magnitude architecture beats other noise-shaping approaches by eliminating all glitches and nonlinearities around bipolar zero and providing near-perfect low level performance with no deterioration in SNR.

### The "Outperformer"

PCM1702's proprietary design utilizes a BiCMOS process to produce a DAC with high dynamic range, high SNR, low distortion, and low power consumption. Try it for your high-end CD players, digital recording playback, automobile stereos, musical instruments and other professional audio applications.

### PCM1702 Key Specifications

- -96dB THD+N max
- 104dB Dynamic range min
- 110dB SNR min
- 200ns Settling time
- 150mW Power dissipation
- ±5V Supply
- 16-pin DIP, 20-pin SOP
- Demo board available

Need a data sheet or more information? Just FAX **1-602-741-3895**.

Or, contact your local sales representative.



Burr-Brown Corp.: Austria (43) 1 602 63 71, France (33) 1 395 43558, Germany (49) 711 77040, Italy (39) 2 580 10504, Japan (81) 33 586 8141, Netherlands (31) 3465 50204, Switzerland (41) 1 7240928, United Kingdom (44) 923 233837.

READER SERVICE 207

# WHAT'S ALL THIS HOAX STUFF, ANYHOW?

**A**s I warned you guys, April is a good time of year to write about hoaxes, and several people have sent me some neat ideas. But one guy asked, "Bob, what is the difference between a Hoax and an April Fool joke?" I told him that you can't tell from the way it starts out, but by the time you get to the end, a good April Fool joke should give you enough clues so you can start to smile. But if you're merely puzzled, or skeptical, that could be a hoax. Conversely, if the guy tops off his story with "and send money," that's a clue that it may be turning into fraud. But sometimes, the guy isn't aware that the situation is impossible—he has fooled himself badly, and may be unaware of the truth. So if you're just listening to the start of the story, *or the end*, you can't always tell.

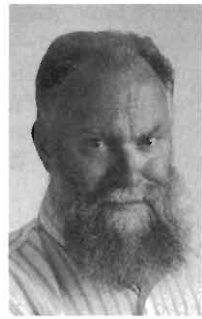

**BOB PEASE**  
OBTAINED A  
BSEE FROM MIT  
IN 1961 AND IS  
STAFF  
SCIENTIST AT  
NATIONAL  
SEMICONDUCTOR  
CORP.,  
SANTA CLARA,  
CALIF.

As I mentioned earlier, some of the stories about Fuzzy Logic start out like an April Fool joke, but after you figure out that the guy is serious, then it's only just funny. However, we have seen some claims, such as "only with Fuzzy Logic can an elevator avoid lurching." That's more like self-deception. Or, "The Sendai train is 10% more efficient than a train without Fuzzy Logic, and runs faster, too." That's a *scream!!* (Details available on request.)

Back in October, I heard a good program about hoaxes on the radio and

sent away for the *Encyclopedia of Hoaxes* that they mentioned on the show.<sup>1</sup> It really is a pretty good collection of Hoaxes, April Fool jokes that went too far, etc. But, unfortunately, it doesn't include any hoaxes in the field of electronics. So after I publish this column, I'll have to send a copy to the author so he can include some of the following stories about hoaxes in electronics.

Let me start out with the Tice Clock. This clock is a basic LED digital clock, substantially identical to a \$30 clock sold by Radio Shack. But George Tice sells this for \$270. He makes some very lavish claims that by plugging this clock into your audio amplifier's main 115-V power socket, the clock will make all your audio equipment sound much better—that is, if you have a "Golden Ear." However, if you can't hear any difference, then you're admitting that you don't have a Golden Ear—that you have only limited auditory capability to appreciate the BEST in audio.

Many reviewers for hi-fi magazines have agonized over this. A few think it's great—the reviewer can really *hear* the improvement. Others search for any plausible technical reason for improvement. One reviewer observed, "If Mr. Tice enclosed a Negative Ion Generator in his clock, maybe people really WOULD think the music sounds better." But he had to concede that there was NOT any ion generator in there. So, many people have come to the conclusion that this clock is (at best) a hoax.

They can't hear any difference, and there's nothing to measure. There's no subjective or objective reason to think that Tice's "clock" can make the music sound better. But it sure takes a lot of *brass* to make such claims.

On the other hand, some people think that painting a green magic

marker line around the circumference of a CD makes it sound better. Some people think that putting a new part number on an old op amp makes it sound better. Some people think that dunking a 16-bit DAC in liquid nitrogen for a while makes *that* sound better. Maybe you can hear the difference. I can't.

Now, let me digress briefly. Let's say you have demonstration models of some good loudspeakers. How do you decide that type A is better than type B, or, that it's *different*? Mr. David L. Clark, Chief Engineer, DLC Designs, Farmington Hills, Mich., combined a set of relays and a random number generator to make an "ABX" tester. If you push the switch for A, the tester connects to the A speakers, or the A set of wires, or whatever. Then you can listen intently and decide that the sound you're listening to is the "A" sound.

If you hit B, you get channel B, and you listen to "the B sound". If you push X, you get a random selection and you jot down whether it's channel A or B. At the end of 10 tests, let's say that you have listed: A, B, A, B, B, B, A, A, A, B. Once that sequence is completed, the ABX box will tell you what it ACTUALLY connected. If you listed 8 out of 10 correctly, that's a lot better than just guessing—you probably did hear a difference. If it's 4 or 5, well... who knows? In some cases, some people with really good ears can hear things that I cannot. In other cases, they're unable to tell. In yet other cases, they refuse to try because they don't like the test.

Still, when speaker cables of different types or characteristics are connected through an ABX box, some people with "really good ears" can hear the difference IF the wires have different amounts of inductance, capacitance, or resistance. It's generally admitted that no matter how exotic the materials or the construction techniques, if two sets of wires have the same R, L, and C, you can't tell them apart. Nobody can.

So you'll find that one guy wants to sell you 10 feet of speaker cable for \$100; another guy claims his are a



# PEASE PORRIDGE

LOT better, and they MUST be better *because* they cost \$300 for 10 feet; and then a similar claim is made for a \$480 cable. But if they all have the same R, L, and C—and each one spouts claims such as.... “superior imaging,” “finer presence and less phase shift,” etc., etc.—that strikes me as somewhere between fraud and hoax.

You can spend your money any way you want to. You can say that you hear a difference. But if I offer you an ABX test, you should not get mad at me and stalk out.

Some of my favorite “hoax” stories are just the claims that manufacturers of speaker cables tell about their wires. I really like the cable with “large-diameter wires to carry the low-frequency music, and small-diameter wires to carry the high-frequency music.” (Of course, it’s easy to compute that the skin effect of copper wire will make a 3° difference in the phase shift of the thin/fat wires at about 300 kHz. And, since the fat wires and the skinny wires are paralleled, you won’t be able to see any significant difference in phase shift at 20 or 30 kHz.)

The other cable I’m impressed with is the stuff that has a conductive “insulation.” When this cable’s resistive losses match the capacitive and inductive attenuation and the conductive losses, and the phase shift is minimized, it should sound better.

Well, if it sounds better to *you*, go ahead and buy it. But, if it just sounds *different*, then maybe you do want to buy it—or maybe you don’t. Maybe when you really turn up the volume, the conductive “insulator” will start to get hot??

Speaking of cables, my friend Tom said that his wife recently went to buy some new speakers at Circuit City. The salesman sold her some new speaker wires “because the old ones were probably worn out.”

Additional amazing audio quasi-hoaxes:

(a) When you have line-level cables (with RCA-type phono jacks), the expensive cables sound *much better* than inexpensive ones.

(b) After you decide to specify the expensive cables, the ones with gold-

plated jacks sound *much better* than the solder-plated ones.

(c) These cables have a preferred direction, and sound better when you connect them up in the preferred direction, with the arrows pointing *from* the tuner *toward* the amplifier.

(d) In addition, these cables sound better if they have been broken in, or *aged*, with a special ac signal forced through the cable.

(e) The best burn-in fixture for these audio cables uses *digital* signals to force current through the cables.

Needless to say, I’ve never heard of any one of these wonder cables being tested with an ABX box. Probably the “Golden Ear” person would object to the relays in the ABX box, as they would *corrupt* the signal. But maybe we could overcome those objections by using a digital burn-in circuit to burn in the ABX box....

The next area I’ll mention briefly is the “vacuum tube sound.” This isn’t about a hoax, but rather a chameleon. It’s well known that some audiophiles prefer audio amplifiers made with vacuum tubes. They claim that the ratio of 2nd-order harmonic distortion versus the 3rd-order is more pleasing with a good vacuum-tube amplifier. Maybe so. Myself, I’ve got a tin ear, not golden, so I’m not very picky. (Maybe I did too much chainsawing as a youth, or turned up the volume on Chuck Berry too many times.)

But Mr. Carver, an excellent designer of audio equipment, came up with a beautiful ploy: He took one of his low-distortion solid-state amplifiers, and added a circuit with a little bit of 2nd harmonic to make it “sound like” a vacuum-tube amplifier.

I’m not familiar with this amplifier’s ABX comparisons, but I think it’s a NEAT idea to make a chameleon amplifier like that. I think it’s great to see if the Golden Ear guys can be fooled.

About 30 years ago, when transistors did not have much performance, a contest was run to make a small high-performance audio amplifier. The late Peter Lefferts won the prize, with a small (6-in. cube) block and heat fins. Inside were a couple of small (6L6GB?) tubes running hot but with good heat sinking. They

were legal under the rules, and nobody else thought of doing that.

A friend told me about a promoter with this scheme: They had a conventional TV transmitter, and at the end of each cycle, just before the zero crossing, they would insert a brief pulse signal before the normal RF signal resumed. Then a specially designed receiver could detect those pulse signals and extract additional info. At 200 MHz, you could also get 200 Mb/s, free, *without any increase* of the RF bandwidth.

Further, this excellent communication scheme was backed up with a U.S. Patent and a big development company formed by a guy named Gerdes. As soon as I heard this line, I got VERY suspicious. My friend promptly admitted, “Of course, after a big press conference where this great technology was announced to the world, several engineers confronted the inventor and insisted that any studies showing you could do that without requiring more bandwidth were obviously malarkey.

The development company folded up.... the promoter hasn’t been seen since.” Yes, *that* sounds like a hoax—or a marvelous example of self-delusion. These days, there are entirely too many cases where computer simulation leads an inventor to believe it will work....

Gunnar Englund of Gransbergsdal, Sweden, once proposed some filters for line power that would filter out any electric power generated with nuclear power. He figured he could sell lots of them to environmental fanatics, with the guarantee that the output power will not show any nuclear residues. But then he got nervous about prospects of a criminal record, even though his guarantee would surely hold up.

Here’s another good hoax: Mr. H. told about a group of engineers at Northrup, who in the 1960s invented a “metric tensor sensor”—a meaningless non-invention with a melodious name. They even got a dummy patent application all drafted. Unfortunately, the senior manager signed it off and sent it to the Patent Office before anybody could explain. THEN they had some explaining to do....

## PEASE PORRIDGE

An engineer from Basingstoke, England, sent in a classy little pamphlet produced by Motorola (U.K.) showing a new non-electromagnetic telephone that used the scientific principles embodied in 2 tin cans and a length of string. VERY nicely done. They even had a rare-earth barrier to protect the inner "Lirpaloo" fiber from fiber-eating locusts. Jolly good.

I have the Abstract of a U.S. Patent—a "Permanent-Magnet-Powered Motor".<sup>2</sup> Of course, the Patent Office won't approve of a patent on a perpetual-motion machine. But this one apparently snuck through.

Then there's Joe Newman who back in the 1980s invented a motor with very high efficiency.<sup>3</sup> It's so efficient, he claimed, that it puts out more power than it takes in. Further, he claimed that he could run a car with no more current than a transistor radio needs. Of course, when engineers saw him loading 1800 9-V batteries into the car, all stacked up in series, they realized that such a battery can indeed provide a full 1/3 horsepower when loaded with 16 mA. If you have a motor that's designed to work at that high voltage, you can indeed move a car at a slow speed for a short distance, as Mr. Newman has indeed demonstrated.

This was the guy who sued the Patent Office after they refused to patent his motor. When the NBS showed that his motor only *appeared* to put out more power than it took in, because he used an RMS voltmeter that couldn't accurately handle the low duty cycles and high harmonics that his motor ran on, he accused them of being incompetent at measuring things!! I've inquired about his progress at promoting his motor, and ran a literature search in our library, but nobody has heard *anything* from him for eight years.

In a scheme with similar ramifications, Norman Dean invented, back in 1956, a machine to "rectify centrifugal force."<sup>4</sup> First he set it up so that incoming rotary energy would cause some jerking motions. These could be synchronously detected by some clamps on a pole, which this apparatus could climb. Then Mr. Dean got the same basic scheme to run *without the*

*pole*, just sitting in thin air! It could turn *energy into force*. He proved that it would do this because he could start it up on a bathroom scale, which would then start to read negative weight! Of course, nonlinearity of the scale mechanism was never considered. I first read about this in "Analog Science Fiction" magazine (which has nothing to do with analog circuitry), in which its masthead conceded that there wasn't necessarily a dot of truth in anything they published. Lovely!!

However, Mr. Dean proposed a large-scale demonstration. Get four of these "Dean Drives," one on each corner of a nuclear submarine, and—presto—you have a nice little space ship! "Why won't the Congress give a fair consideration of my invention?," he bleated.

My demonstration would be even more fun: get a couple of these "Dean Drives" running on the tips of a long rotor in a vacuum. You could put in 100 W, which would generate a certain number of ounces of force. Then, when you get the speed of the rotor up high enough, that few ounces of force would generate more power than the input power—thus, a perpetual-motion machine. Needless to say, this machine generated a LOT of controversy and head-scratching in its day.

Let's mention computers (some people have suggested that almost any use of a digital computer can be considered a hoax....). How fast can a computer display write? One well-known computer benchmarking program yields a result called a "Winmark." Part of the test originally consisted of repeatedly writing to the display: "The quick brown fox jumped over the lazy dog." However, some bright young guy figured out that if he set up a detector for that phrase, he could then shift into a hot-rod mode that couldn't handle anything else, but it could display *that* phrase *really fast*. His Winmark rating was much superior to anything else in his price range, until the trick was discovered. Then, every time a new task was set up, detectors would be told to search for the phrase and go into fast graphics mode. I think they finally gave up on that.

But, that's exactly like the Cor-

vettes that have come out over the last couple years: If you start out moderately in first gear and try to shift up between 16 and 20 mph, a computer predicts that you must be trying to do an EPA test, locking out gears 2 and 3 and forcing you to shift to 4th gear. With this ruse, passing the EPA tests is easy. If you want to defeat this lock-out, just wind it out to 25 mph, and then you can shift into any gear you want, because the computer knows you're not an EPA guy.

A couple of people told me about the young fellow who found a way to get much faster results in general-purpose computing by just adding a capacitor to the main board. Everybody was impressed with his excellent Whetstones! It took several days before some guy with a stopwatch realized that it didn't complete the task any faster—it just slowed down the clock for the task timer. The guy who had made a "lucky guess" did apologize—he really didn't know how he was being fooled.

Bob Dobkin was at National in 1975 when he invented a Darkness Emitting Arsenide Diode. This had many features—light output never fell off with time, and they were cheap due to high yield. Just check the acronym. Then in 1979, Dobkin "invented" a BD-1, a Battery-Discharger circuit. You manufacture this by taking a TO-3 regulator that's dead, and cutting off both pins. Then the resistance from one bolt-hole to the other is about 0.9 m $\Omega$ , and thus can be used to carry hundreds of amperes to discharge batteries, etc.... He got a good paragraph write-up in the April 1 issue of an electronics magazine. We all smiled at that one.

Then a few days later, I ran into Roy Essex, the marketing manager for power regulators. Roy was in a grouchy mood. I asked him why. He rambled on that a customer had called several times to get more information on some absurd Battery-Discharger chip, and he wasn't able to get any information about it, and the customer was getting madder and madder, and if there was any such chip, *he* should know about it, but he had no idea what the customer was talking about....

I replied, "Roy, did he call that

# PEASE PORRIDGE

chip—the BD-1?” Roy spun around: “How did you know that?” I tried to explain that it was just an April Fool joke. That made Roy even madder. Then we realized that the silly customer didn’t realize it was an April Fool joke, as he could not find where it was announced in the magazine. That really got him mad! Roy was mad at Bob Dobkin, and, it seemed, at the rest of the WORLD for several YEARS.

Ham radio guys are always inventing and building equipment, so they’re prime targets for pranksters. In 1966, Tom Kneitel published plans in *S9* magazine for a small, low-cost antenna made of two 100-Ω resistors.

He claimed that “it has the lowest possible VSWR across the entire band with a perfect match to any rig; exhibits an omni-directional null radiation pattern; eliminates adjacent channel overload from strong local signals; may be used either horizontally or vertically; completely ends TVI problems; is impervious to auto ignition noise; and has maximum efficiency at any height. Rust-, corrosion-, and lightning-proof, it can be carried around in your pocket for walkie-talkie use.”

Of course, many Hams built it and complained that they could not get this antenna to transmit or receive *anything*. Exactly... a dummy load. Other famous April Fool stories are about tall antennas that can’t be seen due to use of stealth paint, etc.

When Nikolai Tesla invented the ac induction motor in 1877,<sup>5</sup> which ran with no brushes and no commutator, it was greeted with severe skepticism—must be a hoax. I’m sure if I had been there, I would have been incredulous, too. However, some of the later claims of Tesla border on the bizarre, and may fall over into hoaxery. Claims that electricity can be transmitted around the world with no losses, megavolt sparks under complete control, and an oscillator with an output of 10,000,000 horsepower were pretty wild, impossible to duplicate, and pretty hard to prove or disprove, theoretically or otherwise.

Heck, that reminds me of the April Fool circuit that was alleged to cause

the end of the world if turned on. Some guy wrote that he built it and pushed the button, but complained that the world did *not* end when he pushed the button. Tesla’s ghost??

Because I’m not knowledgeable about Software, I will not have much to say here, except to quote from a News Release—*Vogon News*<sup>6</sup>: “In an announcement that has stunned the computer industry, Ken Thompson, Dennis Ritchie, and Brian Kernighan admitted that the UNIX operating system and C programming language created by them is an elaborate April Fools prank kept alive for over 20 years.... ‘As a lark, we decided to do parodies of the Multics environment and Pascal... we stopped when we got a clean compile on the following syntax:

```
for(;P(“\n”),R-;P(“|”))for(e=C;e-;P(“_”  
+(*u++/8)%2))P(“| ”+(*u/4)%2);
```

“To think that modern programmers would try to use a language that allowed such a statement was beyond comprehension! We actually thought of selling this to the Soviets, to set their computer science progress back 20 or more years. Imagine our surprise when AT&T and other U.S. corporations actually began to use Unix and C!....” Beyond that, RAP has no comment. (Complete details available from RAP with SASE.)

In another case of subterfuge, a friend gave me a copy of a Special Announcement—“After a long period of research and development, Mohawk Engineering announces a revolutionary new switch and charging system... which allows a battery system of any type to supply power to a load or device while automatically and simultaneously allowing the battery to recharge itself.” Complete blueprints can be obtained for just \$100 from a post office box in Springfield, Mass.

Back in 1958, some engineers were quite unhappy about the quality of papers being published at conferences, so they wrote up a marvelous piece of puffery about their new “Linstor.” This paper was accepted at WESCON. Then they revealed that their new invention was an alternate way to describe the *resistor*. Their prank had the desired effect when

technical conferences began screening the papers more closely.

Recently, a Reviewer was evaluating a “Scantrack 18 Golfball Finder”.<sup>7</sup> After diligent and fruitless efforts to find any “output” from this little \$89.95 gem, which uses “new microchip technology” to detect the “molecular wavelengths emitted by golf balls,” he got mad and X-rayed it, and found it completely empty. No circuitry at all. Wonderful hoax.

What was the year—1978?—when Signetics brought out the WOM—the Write-Only Memory? Not just any simple April Fool joke, this marvelous invention was professionally presented in full color in a four-page fold-out section of electronics magazines. Even us Analog guys got a good giggle out of that one! I’ve occasionally wondered what \$ was paid for the publication of that fine joke—and by whom!!

One does still see, in cheap magazines and on odd radio stations, advertisements for the little box that “turns your house wiring into a giant TV antenna.” I asked my friends who are knowledgeable about TV and ham radio. One said it was just stupid, because it did all of the wrong things with the signals. Another guy said its theory was dubious, but actually he had seen it work better than a rabbit-ears antenna. *Consumer Reports* says this kind of antenna usually does more harm than good<sup>8</sup>—a bad investment for \$1.99 in 1973, and a bad investment for \$19.95 in 1994.

At least one guy thinks that ISO 9000 is a first-class hoax. I will admit that we may be forced to conform to the minimum requirements of these regulations drafted by a bunch of European bureaucrats, in order to do business with Europe. However, I agree with George Lohrer of Programmed Test Sources Inc.<sup>9</sup> that some of the zeal we see for super-compliance and “we can meet ISO 9000 better than you can” is pretty disgusting. Copies of his letter available from RAP per SASE.

One of my readers spotted a case where a hobby magazine ran a build-it-yourself article. A special 24-pin IC, available from the author for just \$30, was used to make an interface be-



## PEASE PORRIDGE

tween a Macintosh computer and an ordinary video display. However, the actual circuitry inside this 24-pin IC was just a 7404 inverter IC, encapsulated with a funny pin-out. Ahem.

Obviously, I don't know half of the good electronic hoax stories in the world, but, hey, we have run out of room, so we will just print what we got. If you know a better one, we may run it next year.

All for now. / Comments invited!  
RAP / Robert A. Pease / Engineer

Address:  
Mail Stop D2597A  
National Semiconductor  
P.O. Box 58090  
Santa Clara, CA 95052-8090

1. *Encyclopedia of Hoaxes*, Gordon Stein, Gale Research, Detroit, 1993. ISBN # 0-8103-8414-0. About \$49.95; phone: 800-877-GALE; fax: 313-961-6083.
2. U.S. Patent 4,151,431, "A Permanent-Magnet-Powered Motor," Howard Johnson. Filed Dec. 6, 1973; issued April 24, 1979.
3. "Energy machine floats in perpetual limbo among agencies, court," *Electronic Design*, July 24, 1986, p. 155.
4. U.S. Patent 2,886,976, "System for Converting Rotary Motion into Unidirectional Motion," Norman L. Dean. Filed July 13, 1956; issued May 19, 1959.
5. "The Fantastic Inventions of Nikolai Tesla," by Nikolai Tesla and David H. Childress, Adventures Unlimited, Stelle, Ill., 1993. About \$17.
6. *Vogon News*, Vol. 1, No. 1, June 1991; VLSI Technology Watch, 100 Business St., San Jose, CA. (Contributed by Bernard L. Hayes, *Computer World*, April 1).
7. "Scantrak 18 Golfball Finder," \$89.95 from Lil' Orbits Inc., Minneapolis, MN. Reviewed in *Popular Electronics*, Jan. 1994.
8. *Consumer Reports*, Jan. 1989, p. 5.
9. "ISO 9000: Barking up the Wrong Tree?," Letter to the Editor by George H. Lohrer, President, Programmed Test Sources, P.O. Box 517, Littleton, MA 01460; published in *RF Design*, Oct. 1993, p. 14.

## Who offers less?



Do you need an efficient 4-bit microcontroller for your application such as clock, remote gas and water meter, display thermometer, pager, LCD game, and contactless card ....? You don't want to make any compromises? Then EPSON with it's SMC 62 family can help you! The SMC 62 family operates from 0.9 - 5.5V and consumes as little as 0.7  $\mu$ A (typ) at 3V and 32 KHz in Halt state.

### Block Diagram of a Thermometer:

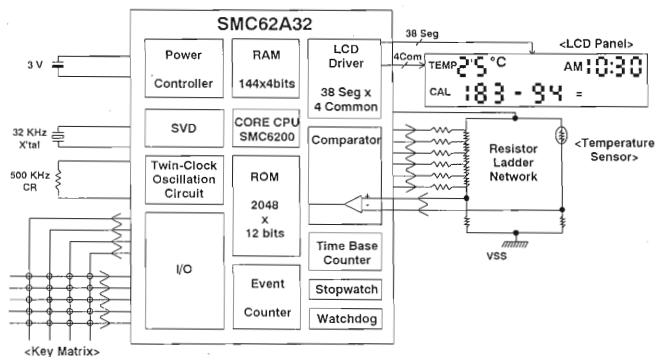

For further information just call your local area office and ask for the OEM division.  
We know we can help

# EPSON

*we're here to help*

EPSON Semiconductor GmbH, Riesstrasse 15, D-80992 München  
Phone +49-89-14 97 03-0, Fax +49-89-14 97 03-10

EPSON France S.A., B.P. 320, 68 bis, Rue Marjolin, F-92305 Levallois-Perret Cedex, FRANCE  
Phone: +33-1-40873737, Fax: +33-1-47372240

EPSON Italia s.p.a., V. le F. Illi Casiraghi, 427, I-20099 Sesto S. Giovanni (MI), ITALY  
Phone: +39-2-262331, Fax: +39-2-2440750

EPSON (UK) Ltd., Campus 100, Maylands Avenue, Hemel Hempstead, Hertfordshire HP 2 7EZ, UK  
Phone: +44-442-227222, Fax: +44-442-227244



# BOB'S MAILBOX

**Dear Bob:**

I have stood on the sideline watching the degree vs. no-degree issue rage on in your column, and have often been tempted to write, but finally I am galvanized to write after reading the letter by Cory Hamasaki in the Dec. 2, 1993 issue. First I would like to say that I have worked as an electronic technician for over 10 years, during which I have worked in all aspects of computers and electronics. I have also spent the last 12 years attending classes part time, working toward a BSEE degree, while working a full-time position.

I take exception to several points Cory Hamasaki stated as fact, but which my extensive experience has shown to be false.

The statement about testing out of lower-level courses for credit is misleading. To test out of a class, a student must take the equivalent of the final exam for that particular class. Due to the theoretical approach of engineering schools, this test will invariably test specific mathematical analysis approaches to electrical circuits. Only diligent and lengthy individual study, or taking the class, will provide this specific information. Testing out of classes is not an option.

The statement about credit for work experience is totally misleading and false if the school is accredited by ABET. ABET specifically does not allow credit for work experience, but only for transfer credit from approved programs. Independent study is allowed for three or four credit hours at most engineering schools, but so far my inquiries have received the response that previous work would not apply.

Also, almost no credit I earned towards my Associate degree in electrical engineering technology was transferred towards my Electrical Engineering degree. ABET has ruled that technology and engineering shall never be intermixed.

The statement that a school would tailor a program if you work with them is ridiculous. I know of no school that would waive their specific graduation requirements. Certainly at the schools I have attended, the Engineering programs clearly define and specify which classes one must take to graduate. There are technical electives that one has the leeway to select to pursue a field of specialization, but these are often the most demanding and difficult classes in the program.

The statement about the professor having real expertise made me laugh. In the last few years, I have learned how not to correct my professors. I realized that this was not helping me get my degree.

In my applied design classes, I now let the professors state whatever false, out of date, and misleading information they want to, and I readily regurgitate this false information on homework assignments, and on tests, so that I get the correct grade. My experience has been that the only time I have not had greater knowledge of the material than the professors has been in the case of my theoretical classes.

The statement about your employer paying for tuition and allowing time off from work also is misleading. It is true that my current employer allows me time off from work so that I may attend classes. They also require me to make up all the time I take off to attend class. Previously, when I worked for a major computer company in a research laboratory, they allowed me time off to attend classes, and paid for my test books and tuition. Sounds great, but the reality has been, and continues to be, that I was resented by my management for taking advantage of this perk.

Certainly, the company's needs have always been expected to come first, regardless of exam or school project assignments. I remember while I

was working there during the semester I took chemistry and differential equations, I was expected to finish a project at work on schedule. This entailed my being out of state frequently during the semester, and often being expected to work 60-hour weeks. Yes, I completed my project on schedule, but my grades certainly reflected the time I was allowed to pursue my school work.

With all this griping, you may wonder why I continue to pursue this degree. It is because I am tired of having to prove the hard way that I know what I am doing. I am tired of having people automatically close the door in my face because I do not have a degree. Currently, I am the Laboratory Manager for a small computer research company, but I am only begrudgingly allowed to perform design tasks, as I am not an engineer.

Recently, I have had design consulting opportunities that I learned more from while performing my job than I have learned from all my classes. But I will persevere, so that hopefully sometime soon I too can put BSEE after my name.

Thanks, Bob, for writing such an insightful column. It's always refreshing to read something so firmly grounded in reality

**WILLIAM C. SCHNEIDER**  
**Blacksburg, Va.**

*I figured that it would turn out like this. Good luck on your degree work—and on your REAL education.—RAP*

**Hi Robert:**

I was reading your column on "Technical Reading Stuff" in the March 7 issue, and much to my surprise I noticed that you had a question about books on printed circuit design. There are currently two books covering this subject that I can recommend highly to those who would like to do some real art and get away from the mechanical humdrum of CAD design software.

**I LOVE IT.**

**I HATE IT.**

**IT WOULD HAVE BEEN HER BEST BIRTHDAY EVER, IF ONLY SHE HAD BEEN GIVEN . . . A U.S. SAVINGS BOND!!!**

**Why force your family and friends to fib? Give them gifts they'll truly appreciate. Because U.S. Savings Bonds grow in value, they're gifts to be remembered for years to come.**

**Just visit your bank, and when you buy the Bond, ask for a U.S. Savings Bond gift certificate. And keep your family and friends honest.**

Take Stock in America **U.S. SAVINGS BONDS**

**A public service of this magazine**

## PEASE PORRIDGE

Both of these books were published by Bishop Graphics, which is now owned by Chartpack Co. I do believe they are still available, however. The books are titled *Analog Printed Circuit Design and Drafting* and *Digital Printed Circuit Design and Drafting*. Both are by Darryl Lindsey and should be available from Chartpack for about \$60.00 apiece. A beginner's layout kit used to be available from Bishop for both texts, but I don't know if that's still the case.

Any person that reads these books will find they are well written, although details on why things are done thus and such are sometimes scant. These books are oriented toward the artistic as well as the practical user with 3-color plates illustrating the art masters, and exercises to boot. As a professional "layout/designer" type I would recommend these books for anyone who is at an entry or advanced level.

The one piece of advice I can give to anyone who wishes to pursue board design is know how to draft by hand (as well as by computer) first. To achieve elegant as well as functional layouts that are logical, one must be a lot of artist, with very little engineer/designer.

It takes a God-given talent to really excel in laying out boards that are superior to PC-generated objects, but anyone can benefit from the knowledge contained in these volumes.

**ALAN C. BOYLE**  
Bakersfield, Calif.

*For some aspects of layout (grounds, noise, crosstalk, interference), the engineer's insights are still quite important. We found where to order those two books, and also a book on Surface Mount Technology (\$72.40). Call Fine Line Photo at (800) 560-8400. I'm buying all three books.—RAP*

All for now. / Comments invited!  
RAP / Robert A. Pease / Engineer

Address:  
Mail Stop D2597A  
National Semiconductor  
P.O. Box 58090  
Santa Clara, CA 95052-8090

## CLASSIFIEDS

### SURPLUS INVENTORY

**SURPLUS SALE**

**200,000 WALL TRANSFORMERS**

7.5 VDC	50 MA	0.85
12 VDC	100 MA	1.10
12 VDC	500 MA	1.75
12 VDC	800 MA	2.10
14 VAC	500 MA	1.75
16 VAC	1.25 A	2.95

Min 1000/type -- Call for other types

**SURPLUS TRADERS**  
PO Box 276,  
Alburg, Vt. 05440  
Tel: 514-739-9328  
Fax: 514-345-8303

**FREE CATALOG!**

### EMPLOYMENT OPPORTUNITIES

**ENGINEERING EMPLOYMENT NATIONAL JOBS!**

- 100s of Engineering Jobs listed each issue.
- Current openings are mailed bi-weekly.

To subscribe send a check for \$29.95 for 12 issues to: Employment National, Dept. ED041894  
27616 43rd Place S, Auburn, WA 98001

**DESIGN/DEVEL. ENGRS./MGRS.**  
\$30,000-\$70,000+

30+ yrs. in placing Electrical/Electronic Engrs. Nationwide client list and 200 associate office resources. All fees Co. paid. Contact Gordon Hassell with resume/salary/location data. G.E. HASSELL ASSOCIATES, 913 MAIN PLACE, P.O. BOX 471, NILES, OH 44446. (216) 652-5871

**TAKE NOTE!!!**

**Recruit Top Talent** for your company by placing your classified ad in this publication.

For more information contact:  
Lois Walsh  
(216) 696-7000, ext. 2359  
or  
FAX (216) 696-8207



# WHAT'S ALL THIS APPLES & ORANGES STUFF, ANYHOW?

**Y**es, recently I was invited to take yet another "Training Course," following in the path of great successes such as Taguchi Methods, Fuzzy Logic, and Time Management. But why would this course on basic accounting and economics be called "Apples and Oranges?" Because, the course's leader explained, if one person has apples and another person has oranges, the only way to quantify the sum total of the two fruits is their value in dollars. So we quickly dropped the old aphorism that "you can't compare apples and oranges," and started talking about dollars.



**BOB PEASE**  
OBTAINED A  
BSEE FROM MIT  
IN 1961 AND IS  
STAFF  
SCIENTIST AT  
NATIONAL  
SEMICONDUCTOR  
CORP.,  
SANTA CLARA,  
CALIF.

hundreds of a manufacturing plant are used to compute the profits, and how the costs and expenses and assets are added and subtracted and divided to compute the Return On Investment. Michael, the leader, gave us an explanation of how the "game" is supposed

to run—a discussion of how this little hypothetical "factory" buys raw materials and adds labor to accomplish the manufacturing of Widgets. Then the Widgets were put into "Finished Goods" to await customer orders. Over the course of a year, this factory was able to show a good operating profit. But after expenses for interest and taxes, the after-tax profit was only \$2 million—not a very good profit on \$80 million of sales.

Michael suggested that we go back and recompute the profits if we went back and followed a different game plan: We should pay off \$20 million of our liabilities (bank loans) with some of our cash. Sure enough, at the end of the year, the net profits looked considerably better, about \$3 million. Further, he suggested that we should not keep a lot of our finished products in Finished Goods (or, "Box Stock", as we call it at National), but we might plan to just build our Widgets to meet customer orders. We could save a lot of money by not having a 3-month stock of expensive assembled parts waiting around for customer orders. FURTHER, we could save additional money by not buying our raw materials from just any cheap suppliers, but rather by choosing a "small number of very reliable suppliers" that we could trust to ship us our raw materials on a JIT (Just-In-Time) basis. This saves more money by not having raw materials sitting in our storehouse for a long time. Altogether, after we ran the numbers through the exercise, our new lean, mean company had made \$6 million of net profit. Wasn't that a lot better, asked Michael?

I spoke up, "HELL, NO! The only reason we were able to save \$4 million in interest was because this whole sce-

nario was set up badly. In the base example, the company treasurer sat on an average of \$51 million of cash, and never even put it in the bank to earn daily interest. The only way we could show an improvement of \$4 million on interest was to ignore the fact that the treasurer had wasted \$8 or \$10 million in interest he could have earned. Even in the second scenario, there was \$3 or \$4 million left lying on the table due to the treasurer's ignorance and/or incompetence.

It's absurd to argue that one plan shows superiority if it's only compared to a Straw Man." (As you can see, I am not a big fan of Straw Man comparisons....) So the lecturer immediately spotted me as a troublemaker. "Well, yes, you are right, but we just have to follow these examples and procedures for accounting, which are, of course, simplified."

Next I complained that if you order your raw materials from "a limited number of highly reliable suppliers" for the purpose of getting "JIT delivery," you should honestly expect to pay more for that. I've heard that half the trucks in Tokyo are driving around in circles, half-empty, wasting time so they can show up at JUST the right minute, neither late nor early.

This might make your assembly operations simpler, but that JIT service is NOT free, and not necessarily cheap. Somewhere, somehow, you will pay for it. Further, one traffic jam, one flat tire, and your production line goes down. "Yes, but we are just following our guidelines, which are of course simplified..."

Later, I pointed out, after the game had been played for three years of financial analysis, "Isn't it kind of stupid to make only \$80 million a year of these Widgets? What the heck is going on? In most cases, if you spent another \$1 million to hire some better salesmen, you could sell a lot MORE than \$80 million, and the increased profits would more than pay for the cost of sales." NOW, I must admit, in a hypothetical example, maybe we can't be more specific on what a Widget really is. So if a "Widget" is a kind of commodity such that, no matter how many you have, no matter how

# PEASE PORRIDGE

smart the salesmen are, they could not sell more than the customer was planning to buy—then we should not insist on hiring better salesmen. But otherwise, we would be remiss if we didn't study that possibility. The Instructor agreed that, in some cases, expanding sales is indeed the right thing to do, but there was no room to show that in this simplified example.

After Michael begged me not to be such a disruptive influence during the class, I met with him during lunch hour. I pointed out that in his "simplified" example, he claimed that he was able to sell the same \$80 million of Widgets by manufacturing them on a Just-In-Time basis. But at NSC, we often found customers who WANTED to buy a product from stock RIGHT AWAY, but if we had nothing in stock, they would have to buy elsewhere.

So IF you're in a business in which you're SURE that nobody will buy MORE parts just because they are on the shelf, and you're SURE nobody will buy LESS just because the parts are NOT on the shelf, well, go ahead and do your JIT manufacturing. But I warned him that this OVERSIMPLIFICATION was NOT necessarily good for business, NOT good for profits, and NOT valid for improving ROI. He conceded that my arguments might have some truth—but there was no room for them in this simplified analysis.

One of the other students said, "Well, Bob, you may not like the simplified stuff in this course, but it sure got you thinking." I replied that I had been thinking about this very seriously for several years, and I already figured out some of the weaknesses of JIT manufacturing. Hearing this guy just preaching oversimplified economics got me so ticked off that I was going to do something about correcting this problem. And even though *your* company may not make the same kind of products as mine, you probably face the same kinds of issues.

Where I work, I'm often concerned about how we can avoid a complaint from a prospective customer: "How can I design in your parts right away if your samples are only available on a three-week delivery from Malacca?" So I worked pretty hard with our

planners to maximize our ability to ship evaluation samples overnight, or in 1 or 2 days. But I have to fight with some guys who think that keeping our samples in the low-rent district of Timbuktu is a great way to save money. I certainly don't need a training course to simplify things to the point where people think that the cheapest costs are always the right solution.

Furthermore, I do get calls like—"After I get your new parts designed in, how can I go into pilot production if the availability is 6 weeks?" I point out to them that while we may not necessarily have these parts in stock, we have distributors who do a pretty good job of keeping at least small or medium quantities in stock, so you can order them and get prompt delivery. We want to keep a lean (but not *zero*) inventory.

Now, if a guy complains "I ordered the ICs for my first production run; then the product got HOT and I wanted to double my production run—but the availability of parts was not good. What do I do now?" I've been arguing for years that we should make sure our sole-sourced parts, our proprietary ICs, and, for that matter, any of our products that have a decent volume and good profitability are kept in stock in some reasonable quantity. The alternative is to tell your customers, "We can't help you; you will have to design in our competitor's parts." So when I heard this nincompoop at the training session arguing that we should show a better ROI by only selling Widgets to people who can place orders well in advance of when they needed them, I decided to start chomping my teeth into peoples' ankles to straighten out this oversimplified economic foolishness.

One copy of my first draft went right to our Chief Executive Officer, Gil Amelio, and I have also brought it to the attention of *lots* of other people in sales, marketing, and planning areas. These guys have given me much support and encouragement. Maybe Michael doesn't want any loose cannons in his lecture room, but in the real world, if somebody else doesn't complain about stupid, oversimplified strategies, then it becomes my job. Go ahead, tell me that I'm a loose cannon.

We all already knew that. Even a loose cannon can do some good if it sweeps away cobwebs. Maybe I can't tell the difference between apples and oranges, but I can tell the difference between bad economic theory, OVERSIMPLIFICATION, and the real world.

Now, speaking of oversimplification, when I propose keeping these new, proprietary or sole-sourced parts in stock, I shouldn't imply that it's *easy* to do. Murphy's Law says that as soon as I see a part selling with good volume, and I put a fat amount of them in stock, then people will stop buying them. If I put the expensive one in stock, people will want to buy the cheap ones (and vice-versa); if I stock the mini-DIPs, engineers will specify the surface-mount versions. So if I indicated that keeping the right balance of parts in stock would be easy, I must apologize for my own oversimplification.

We have to try to anticipate our customers' ordering patterns. We have to try to keep a reasonable bank of good, tested dice, so no matter which packages the customers ask for, we can assemble the right ones quickly. To do this promptly may require an agile, fast-response assembly group. This may cost a little more, but the advantages may well be worth it in terms of being able to respond and fulfill customer needs.

Also, that doesn't mean that we just have to keep lots of parts in our store rooms. If one distributor is keeping one part in stock, and another is stocking another part, then we may not have to keep many of those parts around at all. But we have to keep a few around for quick sampling.

I talked with some of the guys who designed the original three-day comprehensive lecture about reality and economics. They were surprised to see how unrealistic and badly oversimplified the economic studies became when they were pared down to a one-day course. They agreed it was probably time to see what we could do to restore some reality to that little course. I sent in five scribbled pages of my suggestions on how to restore some of the redeeming factors. I also invited the accountants who really know what's important in fiscal mat-

## PEASE PORRIDGE

ters to add comments about things I didn't notice, or am not very knowledgeable about. Maybe next year, the "Apples and Oranges" course will not only be "training," but will really *educate* us on how to make our company more profitable! The best way for all you managers out there (and other workers, too) to please *your* customers may involve *thinking*—NOT just referring to some old obsolete formula or cookbook.

All for now. / Comments invited!  
RAP Robert A. Pease / Engineer

Address:  
Mail Stop D2597A  
National Semiconductor  
P.O. Box 58090  
Santa Clara, CA 95052-8090

p.s. Mark Levi, who was involved in the design of the original Apples and Oranges course, and who helped me a lot in getting this column into good shape, suggested I read a book: *The Goal*, by Eliyahu M. Goldratt and Jeff Cox. This is written in the form of a novel about a guy who is trying to run a manufacturing plant in the midst of *all sorts of* trouble. His customers are screaming about late delivery, his workers are setting contradictory rules, his most efficient machines are being misused, and his boss is threatening him.

Meanwhile the bean counters tell him everything he does to improve the situation is wrong. A very stressful job—trying to bring in a few more dollars to show his boss why the plant should not be shut down. This is a COMPLETE antithesis of Apples and Oranges, that Pollyanna-ish waste of time. However, Mr. Goldratt doesn't gratuitously overcomplicate things—he sets reasonable examples and covers one or two problems at a time. Good thinking, good writing. The book was published in 1986 by North River Press, Box 241, Croton-on-Hudson, NY 10520.

You can order by calling (914) 941-7175. Price is about \$19.95. Bravo to a good story-teller, explaining how the real world is horribly different from those orderly, sterile optimization situations you learn about in school.  
—RAP

# More than just a Power Component

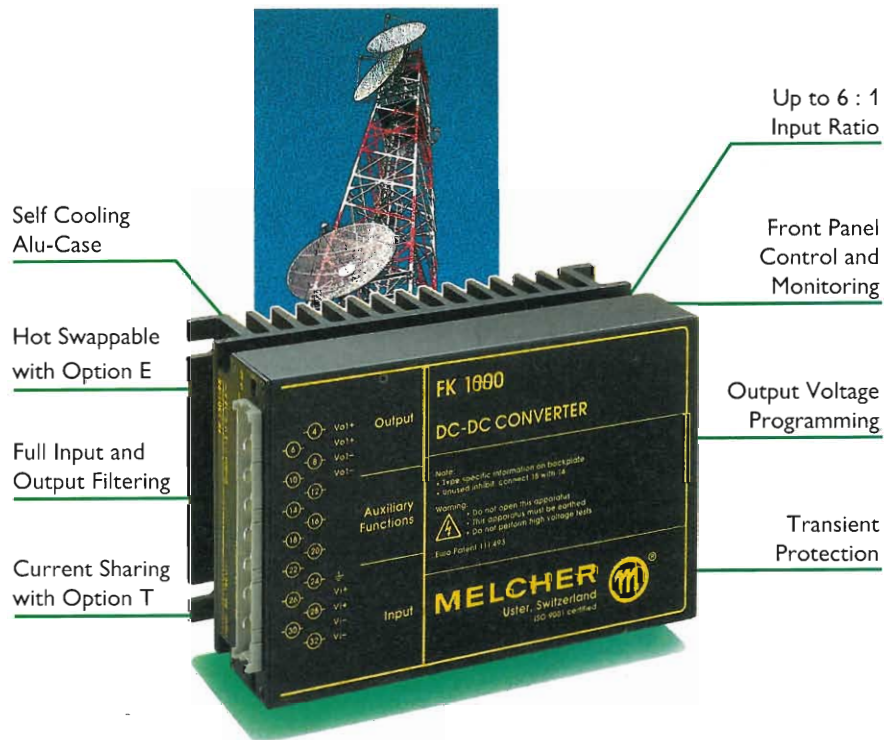

**Are your power requirements too critical for ordinary power components? Our fit-and-forget solutions give you predictable responses to unpredictable environments.**

### K-Family:

- Output power up to 150 Watts
- One or two symmetrical outputs
- Safety according to UL 1950, IEC 950, CSA 22.2 No.950-M89, EN 60950,
- RFI: FCC Part 15, VDE 0878, level B
- Input transient protection according to IEC 255.4, IEC 571, RIA 12
- Overvoltage protection on each output
- Environmental conditions:  
operational ambient temperature:  
-25...71°C (-13...160°F); MIL 810D  
or IEC 68: 5 g vibration, 100 g shock
- Aluminum case, fully enclosed
- Cassette type: 3U x 16HP VME
- Chassis type (with option B):  
168 x 140 x 53 mm

Input [V]	Single Output	Dual Output	Outputs [V <sub>DC</sub> ]
20...100 V <sub>DC</sub>	FK 1000	FK 2000	Single: 5:1; 12; 15; 24; 30; 48 Dual: 12/12; 15/15; 24/24 resp.: ±12; ±15; ±24
28...140 V <sub>DC</sub>	CK 1000	CK 2000	
44...220 V <sub>DC</sub>	DK 1000	DK 2000	Custom output of 2 to 52 V on request
67...385 V <sub>DC</sub>	EK 1000	EK 2000	
88...372 V <sub>DC</sub>	LK 1000	LK 2000	
85...264 V <sub>AC</sub>			

Supplying great Performance

**MELCHER**

ISO 9001 certified



USA: MELCHER Inc. Tel. (800) 828 97 12, Fax (508) 256 46 42  
CAN: MELCHER Corp. Tel. (416) 727 93 41, Fax (416) 727 42 63  
Headquarters in Switzerland. Subsidiaries in Germany, Great Britain, France and Italy

READER SERVICE 156



## PEASE PORRIDGE



# BOB'S MAILBOX

### Dear Bob:

Thank you for your questioning series on Fuzzy Logic and the many claims that have been made for it. Maybe F.L. has a lot going for it, but I have yet to find a clear case of where apples have been compared with apples. I hope a proponent of F.L. can clearly show one. I have read three of the recommended texts on F.L., numerous magazine articles and still remain unconvinced. (Though I must admit the articles by James Sibigroth of Motorola are persuasive.) The Sendai subway train is often quoted as an example of how good F.L. is. But where is a complete and analytical comparison with a good proportional controller implemented in conventional logic?

What has especially clouded the case for F.L., for me at any rate, is the puerile, insulting, and trivial treatment of its supposed advantages. Let me give you a couple of quotes:

1) "Fuzzy Logic lets you assign values instead of crude categories. For instance, if we arbitrarily defined old as over 40, a woman who was 41 would be offended by the old label. With F.L., we can assign membership values to the young and old sets." Really! I'd just call her 41 and avoid any fuss. It's not that I'm a feminist, it's just my analog upbringing.

2) "F.L. does not constrain us to use one or zero, instead we can use intermediate values." Oh great, here I've been thinking that 8-bit micros can support 256 discrete values. Oh well, I learn something new each day.

With this sort of crappola being quoted as reasons why we should embrace F.L., I can get a tiny bit cynical about it. Please, can we see some serious proof from a F.L. proponent?

**BARRY T LENNOX**

Wellington 4  
New Zealand

*Barry, we haven't stopped looking for good Fuzzy comparisons. When we find one, we'll let you know.—RAP*

### Dear Mr. Pease:

I myself might have had an encounter with Roy McCammon's truck-stabilized riometer (March 21 issue) at McMurdo Station, Antarctica a couple of years ago.

I was asked to look at the instrument in question, which was indicating random anomalous bursts of RF energy once or twice a day. The chart recorder indicated only increases during these episodes, so the problem has to be noise or RFI, right? We couldn't use the "diagnostic truck" because some genius had measured the gasoline in the tilted main storage tank at the deep end only, so we were running out of this fuel, and it was three months until the next tanker was to arrive.

So we checked the power supply, walked the cable lines, wiggled all the connectors, took the remote receiver and antenna apart, tried to blame the Navy's 7-kW HF transmitters, tried to blame the power system, scratched ourselves in various places, had a beer, and went to bed.

Next day, out of ideas and probably out of instinct, (I grew up with vacuum tubes), I started pounding on the equipment racks. Lo and behold, the bursts appeared.

The problem was found in a matrix switch for the output of the riometer that was the product of some helpful fellow who had never gone to soldering school.

Why did the output rise during the fault? Two devices shared the low-impedance signal, one high impedance and the other with a substantial positive input bias current. I don't think it was one of your parts. The lessons? 1. If you haven't proven the problem, you probably fixed the symptom. 2. If the problem is smarter than you are, kick the damn thing.

**BILL SCHMITT**

Digiserv Inc.  
Mound, Minn.

*Just as I said in my book on p. 143—when working with intermittents, apply a little FORCE!—RAP*

### Dear Bob:

Thank you for the voice of sanity on the QUALITY stuff. We are a semiconductor division of a large power-supply company. Ever since we first started, we have been using our own, practical, appropriate standards of quality to ship the best parts we could. And we have had the right to fight people, quality experts even, who want to impose rigid standards on us that would actually cause us to ship *more* bad parts to customers, even though we would then conform to a "high quality program."

(Personally, I am of the opinion that it is impossible to create a documentation and specification system that makes a process idiot proof. I confess to having picked up a phrase of yours as an existing operating motto: Thinking is required.)

Our quality philosophy comes down to this: If it smells fishy, don't ship it. How do you know when it's fishy? Smell it, taste it. In other words, test the hell out of it.

- And look at the data.
- And use your intelligence.
- And be skeptical.

There are parts that pass all of the data-sheet specs, but have a parameter that falls outside the usual distribution (note that I do not say "normal" distribution—more later). If you look at the histogram of the parameters of a large number of units, these are the parts in the "tails" of the distribution that trickle away from the main body of the material, yet remain within specification. Those are fishy. They're not the same as the others. Get rid of 'em. Common sense, and many years of analyzing customer returns and field failures, tells me that these are likely to be the parts that give customers conniptions, even though the data sheet tells me there's nothing wrong with them.

Historically, we built product exclusively for our own mother company. But one of the reasons a tiny little 40-person division like ourselves is now generating sales to major outside

# PEASE PORRIDGE

customers is that our philosophy hasn't changed. When you have only one customer, it's in your best interest to make damn sure that the customer will like every part you ship, and "like" is not an objective criterion by any means. "Liking" our product includes, but is not limited to, complying with the data sheet. "Liking" our part also means, "Does it function?" Bizarre as it may seem on the surface, I bet any field applications engineer will be able to tell you about cases where the failed part met every data-sheet parameter, yet didn't function.

More importantly, "liking" our product means, "Is it the same as all of the other material we've been shipping?" The IC engineers in this division wish in their hearts that our customers would actually design with data sheet min and max tolerances in mind. But the fact is, most of the time they just look at a few typical sample pieces and see if their circuit works. Often the IC is just one of dozens of components on a board, and a pretty insignificant one at that, and if they were to actually try to design around a full-spec tolerance of our chip, they couldn't build their product. Yet, in reality, they *do* build their product, and a lot of it, to a high-quality level, and make a profit on it along the way.

So we take the view that, to consistently receive our paychecks, we have to protect the customers from themselves to a large extent. We have to understand their designs thoroughly, from the point of view of the chip, so that we can anticipate where normal variations in *our* process will cause *their* designs to fall out of bed. And usually this means that we have to put intelligent guard bands around our typical distributions. We have to test the parts to know that what we ship is the same as it's always been.

There's another benefit to this philosophy. It produces de facto control limits on our process that reflects the actual "quality" our customers require. And we also find that there are parameters that, while spec'd in the data sheet, really don't matter to the customer. So then, an intelligent guard band on testing is simply the test resolution within the data-sheet limit.

This brings us back to parameter

distributions and the so-called quality programs. We have a number of parameters, like any analog IC manufacturer, that have to be trimmed. Offset voltage of amplifiers and the output voltage of references are the obvious examples. Acceptable process variations create product parameter distributions that do not meet specification, so the product must be designed to allow this parameter to be trimmed. We have had customers and their quality experts insist we "fix" our fab process so that this wasn't necessary, or redesign the product so that the parameter in question becomes "independent" of process. Well, when your products have a bandgap reference, it's a little difficult to design the reference value to be independent of  $V_{be}$ , since it is that very dependence which forms the basis of the circuit in the first place! If you want a tight reference, you're going to have to trim it.

Now, trimming produces a little oddity that *really* confuses quality people. When you get done trimming a reference, for example, you have taken all of the parts and modified their circuitry so that their reference value falls within a very narrow window. The final distribution looks like a box, with absolutely vertical sides and an almost uniform distribution of material within the limits. Then, generally, we get one of two questions:

1) "What happened to the rest of the parts?" In other words, they think we've artificially lopped off the sides of the distribution, which is actually true, but not in the way that they think.

2) "How do you expect to stay within tolerance?" In other words, they calculate the mean and standard deviation on the histogram we sent them, set the 3-sigma limits, and complain that we are going to be out of spec.

Both questions indicate, of course, that they think our quality is going to be lousy because they don't see a NORMAL distribution nicely centered within large process guard bands. And we have to explain, patiently and concisely, that they aren't going to get, ever, any parts that fall outside the spec window, due to the very nature of the trim procedure.

An important footnote to trimming:

It is absolutely critical to lop off the "tails" of the distribution, as described above, *before* trimming the parameter. Designers often include enough range in their trim scheme to allow these tails to be trimmed back into the main distribution, at which point you'll never find the anomalous parts to get rid of them. This is definitely one of those places where testing is critical to maintaining the quality level.

**MARC DAGAN**

*Senior Design Engineer  
Astec Semiconductor Div.  
Milpitas, Calif.*

*Marc, I agree with you on ALL points. Any time you have to re-educate a "Quality Expert," you're doing us all a favor, and I'll support you on that. I hope I have been helpful in deflating the infallibility of "Quality Experts."—RAP*

**Dear Bob:**

I am responding to your Feb. 7 column regarding Dr. Deming and the testing of semiconductor products.

While I am by no means a student of the history of quality control, I believe that you are mistaken in your assertion that Dr. Deming spoke of a need to eliminate all testing for a product and manufacturing process to be deemed "good quality."

Dr. Deming's claim to fame was the application of statistical methodology in the direct management of production processes by the operators and first-line supervisors themselves. It was he who advocated putting the quality assurance into the hands of the operators, as opposed to separate inspectors.

Now, it shouldn't take a PhD to realize that an application of statistical methodology implies the collection and analysis of data. What data? Why the results of in-process testing, of course.

In-process testing can be as simple as the visual inspection of a molded coffee cup or as complicated as the complete parametric analysis of a semiconductor product.

Deming, Juran, and the lot all advocate the liberal use of production process feedback, applied as early in the process as possible. Their gospel has always been one of pushing the testing "up the supply chain" and to eliminate the need for *redundant* testing,

## PEASE PORRIDGE

as epitomized by the classic model of an incoming inspection department that examines everything coming in the door.

**J DAVID EGNER**

**Compliance Engineering Manager  
PowerHouse Systems Inc.  
Menlo Park, Calif.**

*David, we do lots of testing early in our fab, and intermediately, too. But we still depend on Final Test, and so does every other semiconductor maker. If our tester is down, we can't ship!—RAP*

**Dear Bob:**

Re: Your Feb. 7 column on quality. Stripped of its prose, the argument against end-of-line (EOL) testing invariably boils down to the idea that given 100% confidence in the raw materials and the manufacturing process, you need not test the finished product.

I gleaned from your article that the combination of a 40% yield manufacturing process with a 99.995+% confidence EOL test is an economically favorable way of producing high-quality goods in the semiconductor industry, despite the high rejection rate and the cost of testing. This is so because the rejected goods have little intrinsic value, and the tests are quick and cheap compared with the cost of increasing the confidence in the production line.

This would tend to support the notion that the world is not black and white, but a shade of gray. For any given manufactured good, the economically optimal balance between production-line confidence and EOL is not 100% vs. 0%, but somewhere in-between.

**N. LANDMARK**

**Sagem-Lucas  
Birmingham, England**

*You have paraphrased my points, setting them in a new light very nicely. A little practicality beats platitudes almost every time. Deming knew that.—RAP*

All for now. / Comments invited!  
RAP / Robert A. Pease / Engineer

Address:  
Mail Stop D2597A  
National Semiconductor  
P.O. Box 58090  
Santa Clara, CA 95052-8090



## SPARTON ELECTRONICS

**WILL  
BEND OVER BACKWARDS**

for you, and that's what you expect from a world leader in full service custom manufacturing.

**We can design, develop, manufacture and support your product,** with the most innovative, flexible and reliable practices available:

**CAD**

**CONCURRENT ENGINEERING  
DESIGN FOR MANUFACTURING  
STATISTICAL PROCESS CONTROL  
COMPLETE ELECTRONIC  
MANUFACTURING CAPABILITY  
JUST-IN-TIME DELIVERY**

Your Company Can

**MINIMIZE  
INVESTMENT IN INVENTORY,  
FLOOR SPACE  
AND EQUIPMENT COST**

Thereby  
**INCREASING YOUR  
RETURN ON INVESTMENT**

## SPARTON ELECTRONICS

**WE MAKE WHAT YOU IMAGINE**

5612 JOHNSON LAKE ROAD  
P.O. BOX 788  
DELEON SPRINGS, FL 32130

(904) 985-4631 FAX (904) 985-5036



# WHAT'S ALL THIS TELEDELTO'S STUFF, ANYHOW?

I mentioned, some time ago, that Bob Widlar used to use his "Mexican computer," namely, Teledeltos paper. This is a kind of resistive paper that you could use to make analogs or analogues of various physical items.

Well, several people wrote in to ask, where can one buy some Teledeltos paper, these days? I checked around and found quickly that the last 3 places we had bought this paper were not in business any more. That's one of the problems you get when you buy a 5-year supply of something—after 4 years, you find that the guy has gone



**BOB PEASE**  
OBTAINED A  
BSEE FROM MIT  
IN 1961 AND IS  
STAFF  
SCIENTIST AT  
NATIONAL  
SEMICONDUCT-  
OR CORP.,  
SANTA CLARA,  
CALIF.

out of business—and, since you haven't bought anything for 4 years, no wonder.

Our Librarian Mary Holland was agreeable to trying to help me find, where *can* you buy it? We still had several yards left, but we did not have enough to give or sell to all the people who wanted some. Mary did a search of businesses who might be selling anything by that trade name. No luck.

Then she started doing searches of the technical literature and journals. She found some Englishmen who had used it as recently as 6 or 8 years ago, in various technical studies.

Unfortunately, I was not able to contact any of those people to talk to.

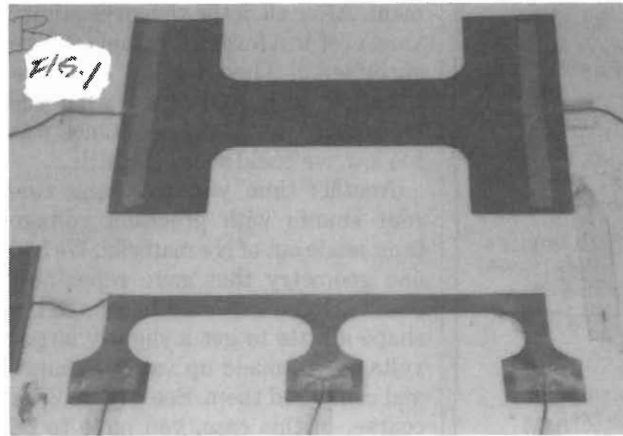

But Mary did not give up easily. She searched for companies in the United Kingdom who might be making or selling this Teledeltos paper, and she found a company—Sensitised Coatings, Bergen Way, North Lynn Industrial Estate, Kings Lynn, Norfolk, England PE30 2JL.

After a little planning and negotiating, we were able to arrange a business deal, to keep it in a simple form, so anybody who wants to buy some Teledeltos paper can do it easily:

Simply buy an International Money Order for 44.00 pounds sterling (about \$70). This pays for everything, including the paper, tax, packing, plus shipping, air freight to anywhere in the U.S.A.. (Unfortunately, the fee for the Money Order will be about \$30, but that is an acceptable expense, if you are warned.) Send this money order to Mr. David Eatwell at the address above. This will soon get you a roll 29-in. wide by 45-ft. long, about 6 kilohms per square, Grade SC20.

Or if you send a money order for 36.50 pounds sterling, you can get a roll 18 in. x 59 ft., tax and air shipping included. Either way, the price per

square foot is about the same, about 85 cents per square foot, fairly reasonable, as most experiments take only 1/2 or 1 or 2 square feet.

Now, while you are waiting for the paper to arrive, you have to get some conductive paint. You can buy 1/2 ounce of silver-loaded paint for about \$36 from various hobby stores. The only problem with this stuff is, after you open it once, you come back in a month and it's all dried up. There are various kinds of conductive sprays or paints, and I do not have much luck finding them in stock, or getting them to work. At present, Planned Products, 303 Potrero St. (Suite 53), Santa Cruz, CA 95060 sells a new product, 1/2 ounce of silver-loaded epoxy (mix equal amounts of 2

components and it will cure in 10 minutes). I bought some, and it works well (about \$14.95). You can phone them at (408) 459-8088. Also buy several inexpensive brushes and get some soft stranded copper wire.

OKAY—now that you have all this STUFF, what can you do with it? You can make a resistive analogue (or analog), a model of the physical thing you want to analyze. I have used it perhaps a dozen times since I was a sophomore at MIT, and on each of these occasions, it was exactly the right thing to do the job.

One of the early uses of this paper was to model the potentials in a vacuum tube. You paint onto the paper, a conductive pattern that represents the cathode, grids, and plate, and use conductive cement (or paint) to connect wires to those regions. Then you apply some voltages to the elements, and look for the patterns of the fields and the equivalent electron flow.

Now, you don't have to apply 300 V just because you are modeling a tube. This is an analog, remember, and if 5 or 10 V is convenient, then all the signals are proportional. You can

# PEASE PORRIDGE

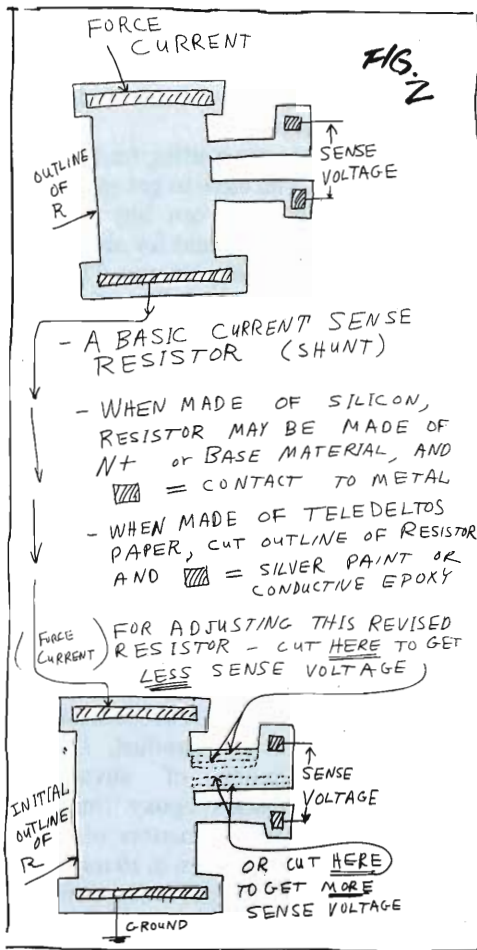

Teledeltos paper are cut, and contacts to the resistor are made with conductive paint. I've used it to compute the resistance of a low-ohms thin-film resistor with the smallest legal shape I could make. I painted along the ends of the resistor. Then I made the outline of a simple rectangle so we could establish the sheet resistivity of the paper right adjacent to the experiment. After all, if the sheet resistivity varies 5% in a few inches, you can't be surprised.... Then we did some ratiometric tests and found what the resistance was. If the resistance was too low, we could slice off a little.

Another time, we made some current shunts with precision voltage taps, made out of N+ material. We had one geometry that gave repeatable results, and we wanted to change the shape a little to get a slightly larger voltage. We made up various shapes and compared them. See Figure 2. Of course, in this case, you have to be very careful not to nick the paper when you cut it, or you'll have a bad flaw in your analysis.

Figure 3 shows how Bob Widlar used this Teledeltos paper to define the sizes of several strangely-shaped emitter ballast resistors in his high-performance circuits. If there are any old-timers who have had other uses for Teledeltos paper, we will be interested to hear what they say.

I talked to Mr. Ken Eatwell, who worked with Teledeltos paper in its early days. He explained this paper was first developed in the United

States by Western Union about 1936, as a paper sensitive to electric pulses, for the new Facsimile (Fax) machines. After the war, the Creed Co. (a subsidiary of ITT) started to make the "L39" paper, under license in England. Originally, the carbon-loaded paper was coated with dark gray lead thiosul-

fide, but for a better image, this was changed to a lighter gray copper thio-cyanate. In the 1950's, Creed decided that the Fax business would never go anywhere, and got out of the business. Mr. Eatwell thought they were wrong, and started his company, Sensitised Coatings. These days, Fax machines use thermally-sensitive paper, or plain paper with a laser engine or ink jets.

Now is this paper adaptable to a 3-dimensional study? Generally not. I would love to have some 3-dimensional resistive stuff, to help me estimate thermal impedances and thermal cross-talk on an IC die. But I don't think the Teledeltos paper gives me any help there.

Three-dimensional flow is a whole 'nother ballgame. I have thought about making a capacitive analog using a large tub of oil in the shape of a die, with little electrodes in the shape of the heat sources. I am sure I could do this, but I haven't gotten exactly desperate enough to make this one. Besides, one spill and I'd be banned from our lab for life.

Could a powerful modern computer do any or all of this work? Quite possibly, using Finite Element Analysis. But if there is an error in there, you are not likely to find it. If you make an error with Teledeltos paper, you have to think about the shape of the curves, and you may get enough insights that you would catch a mistake. Also, for certain kinds of geometries, the Teledeltos paper may be really easy to apply, when defining the shapes for a computer might be excessively hard.

Is the Teledeltos paper really the hard way, the old-fashioned way? Maybe it seems old-fashioned, but if it gives you some good insights, then it may be a superior technique. And it may be easier than typing a whole bunch of data into a computer.

All for now. / Comments invited!  
RAP / Robert A. Pease / Engineer

Address:  
Mail Stop D2597A  
National Semiconductor  
P.O. Box 58090  
Santa Clara, CA 95052-8090

probe carefully to see where the equipotential lines are, using a sharp probe, very delicately. You can also conclude from this that the current flow is orthogonal to the lines of equal potential.

Figure 1 shows a typical example of how you can make an oddly-shaped resistor, where the outlines of the

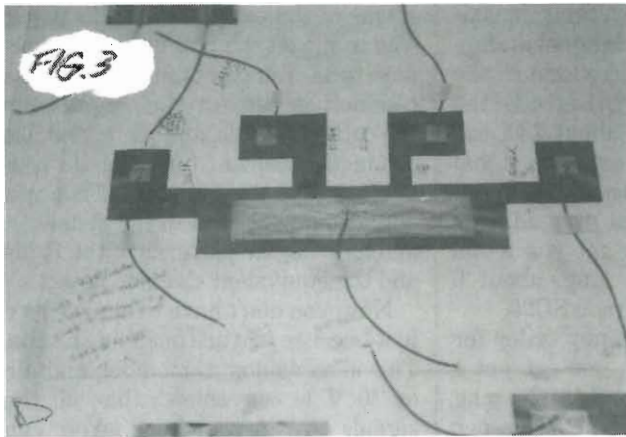

## PEASE PORRIDGE



# BOB'S MAILBOX

### Dear Mr. Pease:

You owe a profound apology to approximately 600,000 radio amateurs in the United States for the remarks you made about them in your April Fool's Day piece in the April 4 Pease Porridge

You were right when you said "...ham radio guys are always inventing and building equipment so they're prime targets for pranksters." But you missed the mark a mile when you went on to describe how "many hams" built the 50-ohm dummy load described by Tom Kneitel in his 1969 article in *S9* magazine.

First of all, *S9* was a publication aimed at citizen's banders and ham wannabes, *not* at hams. The real ham publications available then were *QST* (the widely respected and often quoted journal of the American Radio Relay League), *73* (an independent magazine aimed largely at gadget builders), *Ham Radio* (a technically-oriented magazine written mostly by engineers), and *CQ* (written then, as now, for hams who like contesting and DXing).

Now you may not be aware of the difference between citizen's banders (CBers) and hams, so let me give you just a few of the highlights:

- In 1966, hams, even at the lowest beginning level, were required to pass federally supervised examinations covering technical subjects (resistors, inductors, and capacitors in series/parallel, resonance, antennas, etc.), governmental rules and regulations, propagation, and operating procedures. They also had to demonstrate the ability to send and receive Morse code at 5 words per minute. Higher-class amateur licenses had more difficult tests and faster code requirements (13 WPM or 20 WPM). CBers in 1966 only had to apply for a license. Today, hams are still rigorously tested before earning their licenses. CBers are not even required to have licenses.

- To obtain my Technician Class license (one step above bottom) back in 1959, I was required (among other things) to draw from memory the schematic of a push-pull twin triode power amplifier with link-coupled input and output; and cross-coupled neutralization. Could RAP have done that at age 17? Could he do it today?

- Hams are allowed to operate on any frequency within their many bands (some are hundreds of megahertz wide). CBers are allowed to operate on only 40 specific frequencies in the 27-MHz band.

- Hams are allowed to design and build their own equipment; CBers may buy only FCC type-accepted equipment. Hams may adjust and modify their equipment; CBers are not allowed to tamper with the circuits.

- Hams are permitted to transmit using up to 1500-W PEP output; CBers are limited to 10-W PEP.

- Hams are allowed to utilize many different modes of communications: AM, FM, PM, SSB, code, slow-scan TV, fast-scan TV, fax, teletype, packet data, and spread spectrum. CBers are permitted only voice, using AM or SSB.

- Hams are permitted to build and operate mountain-top VHF repeaters to extend the range of their handheld or mobile radios; CBers may not. Hams are allowed to design, build, launch, and operate their own satellites (there are several in orbit as we speak); CBers...well, sorry.

- Hams have gathered world-wide acclaim for selflessly donating millions of man-hours every year to provide the public with emergency communications in fires, floods, hurricanes, war, and earthquakes.

I could go on at length, but perhaps by now you get the idea. And while I suppose it's possible that a few hams might have been fooled by the *S9* article (just as at least one engineer was taken in by the BD-1 article), it seems

unlikely that "many hams" would be taken in by a pretty obvious gag in a CB magazine. More likely, the victims were naive CBers who had never heard of a dummy load.

**BARRIE G. BRITTON**  
*Amateur Radio K0WWG*  
*Riverside, Ca.*

*Okay, probably I should have said "several CB guys and a few hams" were fooled into building the dummy load. I'm sorry!—RAP*

### Dear Mr. Pease:

Your "Pease Porridge" column in the April 4 issue was sent to me by a friend. In your conclusion, you admitted not knowing half of the good electronic hoax stories in the world. Conversely, you can't know all that is true.

Your reference to Nikola Tesla reminded me of a letter once received from a technician who was skeptical of Tesla's claims of having produced "electrical movements not only approximating, but, as shown in many comparative tests and measurements, actually surpassing those of lightning discharges." The skeptic informed me that lightning discharges reach distances measured in miles. No human, he wrote, could produce man-made lightning that long.

When quoted out of context, Tesla's words appear farfetched. The writer's skepticism is understandable. However, when I asked the skeptic if he had ever analyzed Tesla's work or read papers of those who did, his reply was negative. Experts on lightning have shown that thunderclouds vary in coulombs from 12 to 600. When researchers James and Kenneth Corum analyzed Tesla's experiments at Colorado, they determined Tesla's machine to have achieved 260 coulombs. Consequently, the two researchers concluded that Tesla's claim "was no overstatement."

Your skepticism regarding Tesla's claim of wireless power, megavolt sparks, and oscillators producing 10 million horsepower also is under-



# PEASE PORRIDGE

standable. When read out of context, the claims appear so extreme as to warrant ridicule. But, I must ask you the same question that I put to the above mentioned skeptic. There is no need to respond, I know the answer.

Although the mysteries of Tesla's work have not been completely resolved, there exists today a better understanding of what Nikola Tesla did and what he might have accomplished. Tesla spent a year on the Colorado plateau in developing a magnifier that was capable of 100-ft. discharges. He calculated that his machine had achieved 20 million volts at 1100 RF amperes. Armed with new knowledge, he established a plant on Long Island (N.Y.) fully intent on achieving the results to which you refer as a hoax.

A hoax is defined as a trick or a fraud. However, Tesla believed in his calculations and his ability to achieve the desired results. One might accuse Tesla of miscalculation or overstatement, but that would not constitute a hoax.

If you have any interest in Tesla's work, you might find some satisfaction in reading Leland I. Anderson's *Nikola Tesla On His Work With Alternating Currents* (distributed by Twenty First Century Books, P.O. Box 2001, Breckenridge, CO 80424.)

**HARRY GOLDMAN**

**Tesla Coil Builders Association  
Queensbury, N.Y.**

*The energy in a capacitive discharge is  $1/2(CV^2)$ . The amount of coulombs is significant, but I doubt if Mr. Tesla's voltages were as large as those found in nature. I will certainly agree that Tesla's achievements were impressive, amazing, and great engineering.—RAP*

**Dear Sir:**

I'd first like to say how much we all enjoyed your Pease Porridge in the April 4 issue. We have even had people asking for gold-plated mains fuses in the belief that putting a micron or two of gold in the path of the 240-V, 50-Hz mains supply will some how improve the sound of hi-fi... I've considered writing to them suggesting that they ensure that they only receive electricity through underground cables, since

cables on pylons might pick up RF.

However, on a more serious subject, I have to take issue with you over ISO 9000. There are so many misleading statements published about this thing that it isn't surprising that even people like you repeat them. However:

ISO 9000 was not an invention of European bureaucrats. It was actually devised by the British Government during World War II to reduce the vast numbers of inspection systems, contract systems, etc., which were making it hard to ensure that we had the right tools to upset Hitler. After the war, it developed (slowly) into BS5750, the BS standing for British Standard rather than male bovine excreta. BS5750 became ISO 9000 as a result of ISO activity—and ISO is an international body on which virtually every major country is represented, including the U.S.

North Americans tend to forget, or perhaps underestimate, the importance of the fact that in Europe, we have a variety of languages and cultures, and this includes different ways of doing business and different attitudes to the customer. The European Commission has promoted ISO 9000 as a way of removing some of the confusion, just as BS5750 was intended to do during wartime. It means that now, when I try to assess whether (say) an Italian or German supplier has the systems in place to resolve potential quality problems and to give my company what it wants, I have at least some framework to look at with which I have some acquaintance, and that with my limited Italian and German, I can still have a sensible conversation with the supplier. I have to say that from my experience, ISO 9000 is working for us.

It's a means of setting up a quality system with all the necessary parts—calibration, monitoring production, assessing cost of quality, handling customer complaints, etc. It ensures that all essential areas are covered, more or less in the same sort of way. It says nothing about what the quality of a product produced by a company is. This is just like accountancy, which has standard rules for measuring money. You might have a perfect accounting department and still be go-

ing down the pan owing to a severe negative profitability situation. Equally, you might have a perfectly run QA system and make rubbish. However, in both cases, you and people who depend on you will know exactly how bad things are and probably be able to identify some sensible actions.

Many small companies get started and run for years without ever knowing that there are some things they should be doing—keeping records of product introductions and changes, calibrating equipment, etc. All is fine until the day something goes very wrong and someone is in a position to sue them into the ground. For these people, ISO 9000 is a relatively cheap insurance policy. For large companies, with their own hierarchical management systems, this is less of a problem.

If there is a hoax, it is probably promoted by the people who seem to regard certification to ISO 9000 as some sort of quality achievement. It isn't. It was never meant to be. It is an organizational achievement.

My company makes safety-critical products—fuses—lots and lots of them. In Europe, the quality achievement is shown by those arcane symbols—BSI Kitemark, VDE triangle logo, and so on. The bodies that do the testing and the certification believe that our registration to ISO 9000 is evidence that we have a quality system strong enough to ensure that deviations from our quality norm will be quickly detected and made right. It is the combination of ISO 9000 and product approval that is the real measure of quality achievement.

For this reason, the real European Bureaucracy bit is the CE mark. This mark attached to a product is a statement that the manufacturer complies with every quality and performance requirement relevant to product safety, and can prove it. It corresponds, very roughly, with UL listing.

**MARTIN BACON**

**Cooper Bussman**

**Somerset, England**

*If ISO 9000 is really like you say it is, then all of the confusion and misrepresentation and bragging we see is even more disgusting. I have yet to meet anybody that's in charge of im-*

## PEASE PORRIDGE

*plementing ISO 9000 who knows any facts, who knows what really is supposed to happen. The implementation of ISO 9000 is where you don't see quality.—RAP*

### Dear Bob:

Enjoyed reading your article on "Hoax Stuff." However, I was surprised that you didn't mention the Master of all electronic hoaxers, Hugo Gernsback. I am sure you remember him as the publisher of *Popular Electronics* magazine (or was it *Modern Electronics*)? My memory is starting to fade. Anyway, come every April you were sure to find one of his electronic hoaxes in his magazine, complete with all the details.

Of course, when I was much younger (in the early 60s), I didn't know this and as a young and enthusiastic electronic hobbyist, I would build anything for which I could find the parts. One of his articles described the construction of an "anti-electron generator" or something close to that (remember, my memory). The purpose of the anti-electron generator was to do just the opposite of what you would expect a normal generator to do.

For instance, if you plugged a soldering iron into the generator, instead of the tip becoming hot, frost formed. I think you get the idea.

Also, being an amateur photographer, I was more interested in the lamp. When you plugged in an ordinary lamp, instead of light (you guessed it) it took away all of the light in the room and made it dark. What a fantastic invention! I couldn't wait to build my very own. There it was, all the details, schematic, parts lists, photos, and text.

It wasn't until I collected half the parts that I bothered to read the rest of the article. There was one sentence at the end that I didn't understand at first, "...and the circuit only works well on April 1st." I was hoaxed. I was mad, but now I'm glad.

No school could have taught me the lesson I learned from this experience. For the rest of my life, I would treat all circuits (including my own), and all other claims as hoaxes until proven otherwise. Thank you Mr. Gernsback, wherever you are.

A few years ago, I bought a book from Gernsback Publishing, which had a few dozen of his hoaxes, unfortunately not the one above. I was going to send you the book, but I can't find it right now. In the meantime, I thought you might enjoy my story.

**GARY C. FIELDS**  
VP Engineering  
Merge Technology Group Inc.  
Napa, Calif.

*Ah, yes, those "macro-wave ovens" that cool their contents, always have some appeal!!—RAP*

### Dear Bob:

I enjoyed your article on hoaxes, and would like to add a few I've seen or heard of.

Several years ago I saw an ad for an indoor TV antenna that looked like a combination of rabbit ears and a miniature satellite dish. There were several paragraphs of impressive fine print. The unique thing about this ad was it contained no lies at all. It was guaranteed not to incur any cable or satellite fees because it was not designed to pick up any cable or satellite channels. It had the wonderful ability to intercept TV signals right out of the air! They didn't even claim a technological breakthrough. The claim was that this was a "Marketing Breakthrough."

About 25 years ago, there was an article in one of the ham magazines about a "buried antenna" that was said to propagate "ground waves."

A thought on audio specs; if people can get away with making such extravagant claims for a piece of wire, I wonder how many of the specifications for more complex components really relate to differences you hear. Your comments on people with "Golden Ears" reminds me of the "Emperor's New Clothes."

In 1978, an "inventor" named Rory Johnson, of Elgin, Ill., received lots of media attention in the Chicago area for his "Magnetron" car engine, which weighed about 500 pounds, produced 525 hp, and would run for 100,000 miles on a self-contained supply of gallium (a well-known donor source for electricity) and deuterium. He claimed a laser beam caused a fusion reaction between the two elements.

He demonstrated a car with the engine idling, but no one saw the car actually run on the engine due to "safety reasons." Unfortunately, this was not just a hoax, but a fraud, as investors lost hundreds of thousands of dollars. (*Daily Courier News*, Elgin, Ill., Aug. 12, 1977 and Dec. 22, 1978)

**KENNETH LUNDGREN**  
Bloomingdale, Ill.

*Yes—some hoaxes only cost you \$5 or \$10—and others can cost the gullible a whole lot more. People who want something for nothing...—RAP*

### Dear RAP Chap:

Re Hoaxes: My favorite is the "Little Jiffy Fuse Blower" published in *Electronics* (?) before (?) 1953.

Here, a heavy-duty push-button switch was paralleled with an Ampenol chassis-mounting ac line plug in a neat little minibox (about 2-in. cube). The device title is neatly lettered on the box. The builder is instructed to leave the device loose and unguarded on the desk. The device will disappear and soon thereafter the lights will go out in a section of the office. A shame-faced new believer soon sneaks the device back. The author was exactly right, but he didn't mention the switch needs replacing after four or five episodes.

Our local "911" bureaucrats with Postal Service help have renumbered and rezipped our entire road. This falls somewhere between an April fool joke, a hoax, and a fraud. (Some time, figure out change-of-address costs. Of course you shouldn't count the fine for having the wrong address on your driver's license.)

**DAVE GEISER**  
New Hartford, N.Y.

*Yes, several people sent in the "Fuse Blower." In our lab, a specialty was to give a guy a National Semi calculator, that would smoke and burn and explode when switched on!—RAP*

All for now. / Comments invited!  
RAP / Robert A. Pease / Engineer

Address:  
Mail Stop D2597A  
National Semiconductor  
P.O. Box 58090  
Santa Clara, CA 95052-8090

# WHAT'S ALL THIS V-F CONVERTER STUFF, ANYHOW? (PART I)

**I**f you have already read Jim Williams' compilation, "Analog Circuit Design: Art, Science, and Personalities,"<sup>1</sup> then you may look on this column as a summer rerun. However, several people, after reading my 1993 comments on Frequency-to-Voltage converters, asked my opinions on Voltage-to-Frequency Converters. I realized I had written all this down already, so here is a serialized version of the chapter I wrote in Jim's book—reprinted with the kind permission of Butterworth-Heinemann, Boston, Mass. Meanwhile, I'm going hiking.—RAP



**BOB PEASE**  
OBTAINED A  
BSEE FROM MIT  
IN 1961 AND IS  
STAFF  
SCIENTIST AT  
NATIONAL  
SEMICONDUCTOR  
CORP.,  
SANTA CLARA,  
CALIF.

Once upon a time, there were not any Voltage-to-Frequency Converters (VFCs) or any Voltage-Controlled Oscillators (VCOs). I couldn't tell you exactly when that was, but back in the 1950s and 1960s, very few people had ever heard about an oscillator whose frequency could be controlled by a voltage. In those days, when you wanted to change an oscillator's frequency, you usually changed a pot or a resistor or a capacitor, or maybe an inductor.

I checked up on this, because I spent a couple of hours searching in the old MIT *Radiation Lab Series*, published in 1949. There were no oscillators or multivibrators whose fre-

quency could be controlled by a voltage—no VCOs, as far as you could learn by looking at the "Bible" of that time. (More comments to come on this in the next issue.)

It's true that FM radio transmitters used Frequency-Modulated oscillators; back as early as the 1930s, and these were modulated by voltages. But they only covered a relatively narrow frequency. When I refer to a VCO, I'm talking about oscillators whose frequency could be controlled over a range of 10:1 or 100:1 or 1000:1 or more. In general, this type of oscillator is expected to have a pulsed or square-wave output, *not* a sine wave.

Back in 1961, when I graduated from MIT and joined up with George A. Philbrick Researches (127-129 Clarendon Street, Boston 16, Mass.), I joined a company that made operational amplifiers, analog multipliers, integrators, and all sorts of Analog Computing Modules. And just about everything was made with vacuum tubes. There were Applications Notes and Applications Manuals that told you how to apply operational amplifiers (in those days we would never say, "op amp").

And there was the big old Palimpsest, a sort of collection of old stories on things you could do with operational amplifiers and analogue computing equipment. But, there were no digital voltmeters, and no voltage-to-frequency converters.

About 1963, I became aware of a high-performance operational amplifier—the 6043 project. This chopper-stabilized amplifier had been designed by Bruce Seddon, one of our senior engineers and VPs. The customer for this amplifier was Dymec, a subsidi-

ary of Hewlett-Packard (if you turn *dy* upside down, does that look like *hp*?). And this amplifier was to be the front end of a Voltage-to-Frequency Converter instrument. The amplifiers were functioning pretty well, and they were meeting just about every specification. But they had a problem with undesired little offset shifts and jumps.

As the project went on, more and more engineers were looking over Bruce's shoulder, trying to help him solve this problem of the jumpy offset. Some people suspected that the amplifier stages might be rectifying out signals generated by ???, perhaps the transmitter of a local taxicab company? Other people suspected triboelectric effects, or electrochemical contamination.

I don't know if the cause of this drift or wobble was ever resolved—it was hard to resolve just a few dozen microvolts. But I have the impression that the amplifier project was not a success, and we never went into full production. If there was any circuitry of the actual VFC, that was never discussed at Philbrick—that was proprietary within Dymec, and our job was only to make an operational amplifier with low offset.

Of course, this amplifier had several vacuum tubes, and a chopper. The first amplifier tubes, 6CW4 nuvistors, ran with their 6-V heaters connected in series, so as to run on a 12-V dc bus and avoid the noises inherent in using 60 cps heaters. Then there were two more gain stages, dc-coupled. The chopper was an Airpax 172 or Bristol or similar, and there was a chopper amplifier based on a 12AX7. The whole circuit was similar to the Philbrick "USA-3" amplifier. It did, however, run on  $\pm 150$  V instead of  $\pm 300$  V. The late Dan McKenna, the senior technician who worked on the project, said he always suspected it was the fault of the heaters that were connected in series, because the data sheet on the 6CW4s said, "do not connect heaters in series."

But I realized later, connecting two heaters in series was surely OK; putting 10 or 20 tubes' heaters in series, as in a TV set, was the procedure that



# PEASE PORRIDGE

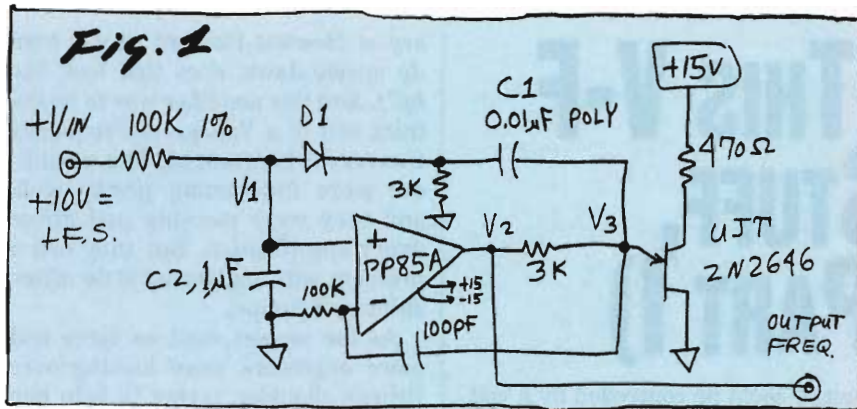

was prohibited. So, even though Dan groused about it, this series stacking of 2 heaters was probably quite wise, not risky, because it would force the tubes to run at about the same amount of watts in each heater.

Anyhow, a design with vacuum tubes is Ancient History. Even then, although we were trying to design part of a V-to-F Converter, we didn't have a VFC in our lab. We didn't have a DVM—we had the old Fluke 805 Differential Voltmeters. Now, these meters have many elements of accuracy that good DVMs have these days, like good resolution and stability. But, they were big and heavy and slow. If you wanted to read 5.032 V, for example, you could do it, but it was a tedious deal.

You had to turn the first knob to 5, and then the next one to 0, and the next one to 3, and then turn up the Gain and look at the analog meter to see if the residue looked like a "2." That was how you learned the voltage was 5.032 V. If you've ever spent a few hours twisting the knobs of one of those old Fluke meters, you'll remember it with some nostalgia, but you must admit it was an awfully boring process.

When the first DVMs arrived from Hewlett-Packard and from Non-Linear Systems, they were slow and (in the case of the NLS) clunky and noisy, and they didn't have excellent accuracy or features compared to the old Fluke Differential Meters. But, they sure were faster and, of course, a lot easier to use.

However, there was another way to do a DVM. You could buy a Voltage-to-Frequency converter from Dymec

and feed its output frequency into an "Event Counter" (an EPUT meter—Events Per Unit Time—from Beckman Berkeley). Its neon-discharge display tubes would glow and tell you what the frequency was in terms of pulses per unit of time, and that was supposed to be linearly proportional to the input voltage.

This new Dymec VFC had several solid-state circuits, and tricky pulse generators. To this day I don't know how those proprietary, secret pulse circuits were supposed to work. It had a pulse generator based on some special pulse transformers and blocking-oscillator circuits. The instrument had a pretty good tempo spec—but that's only because there was a little oven to hold all the transistorized circuits (which REALLY had a rotten tempo) at a constant temperature of +65°C. Consequently, when you turned it on, you had to wait at least half an hour before the accuracy would finally settle out to its ultimate value; in other words, waiting for the oven to settle its temperature. It could handle a full-scale voltage of ±1.0 V. It works

pretty well. The VFC was claimed, originally, to have better than 0.02% of linearity. I measured one recently, and it had some nonlinear errors around 0.024%, which isn't bad. But, apparently, something had drifted slightly out of spec. It cost \$1600, back when \$1600 would buy you a Volkswagen. I still have one of the Dymec VFCs, Model DY-2211B, and the instruction book on it.

Now let's move up to about 1967. We engineers at Philbrick were working mostly on the design of solid-state operational amplifiers—amplifiers made of 6 or 8 or 10 discrete transistors and several resistors and capacitors in a compact potted module that was 1.125 in. by 1.125 in. by 0.5 in. The integrated-circuit operational amplifiers were arriving, but most of them were pretty crude in terms of performance and features.

One day, Bill Bernardi, one of the senior applications engineers, told me that a customer in Sweden had made a linear Voltage-to-Frequency Converter using a PP85A (one of our standard operational amplifiers) and a UJT (UniJunction Transistor). And the nonlinearity was, he said, about 0.1%. When I heard this, I got kind of curious and skeptical, because everybody knows that UJTs are the crudest, dumbest, most imprecise oscillators you can find.

Just about every student learned that a UJT looks very cute because it can oscillate with a minimum amount of external parts—two resistors and one capacitor. BUT, it's an awfully junky circuit. You could gold-plate the sow's ear, and the UJT was still a junky circuit. Besides, I had recently

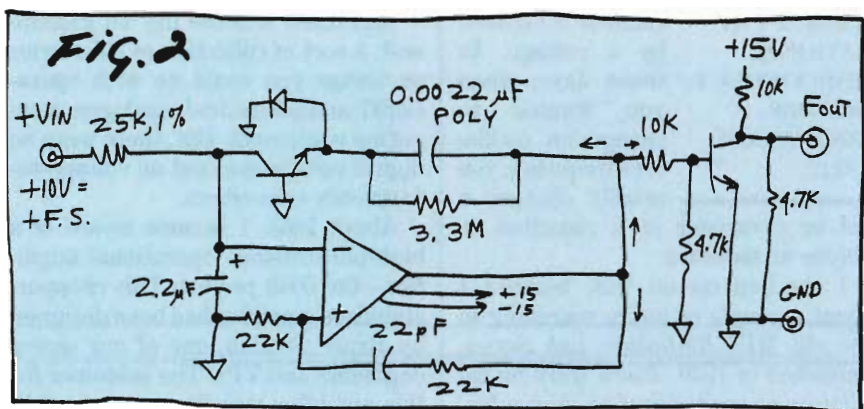



## PEASE PORRIDGE

built some Frequency-to-Voltage Converters, and it wasn't easy to get them to meet 0.1% linearity.

When I heard that a UJT was involved with a VFC of very good linearity, I was impressed, but also suspicious. So I looked into what they were doing. I didn't know anything about Voltage-to-Frequency converters, but I was curious. I found that the PP85A was used as a comparator, and the UJT was mostly used to provide some "negative resistance," or positive feedback, to make a pulse whose amplitude or width aren't critical and thus didn't hurt the accuracy of the VFC. Ah, but how? How is it that a VFC which uses one simple comparator and a crude UJT pulser, and no other obvious precision components, provides a 0.1% linear VFC?

As near as I can recall and reconstruct, the circuit was basically that in Figure 1. The principle of operation is, that when the current from  $V_{in}$  causes the main integrating capacitor C2 to rise up to zero volts and the op amp starts to swing its output positive, the UJT is triggered. The UJT then puts out a crude pulse that kicks the minus input of the comparator. The output ALSO kicks a certain amount of charge through a charge-dispersing capacitor, C1, back to the integrating capacitor, to reset it. This amount of charge must be constant and invariant of anything, especially invariant of the repetition rate. If you can get that, you get excellent linearity. Apparently, the Swedish engineers had stumbled onto this crude but functional circuit.

Now that I understood the principles, I figured out that there was room for a good bit of improvement. I started fooling around with some breadboard circuits. I got the full-scale frequency up to 10 kHz (the Swedish circuit only worked well up to 1 kHz, which isn't nearly as useful), and got the nonlinearity down to 0.03%. And, I invented a scheme so that the operational amplifier's output could be capacitively coupled back to its + input, causing enough regeneration or positive feedback whereby the UJT was no longer needed. I used an Amelco 805BE integrated-circuit operational ampli-

fier as the comparator.

Now, the whole circuit of Figure 2 fits into a 1.5-in. square package just 0.5-in. high—a small epoxy-potted module that was rather smaller than the PP85A amplifier and associated parts. We built up a prototype and tested it, and it worked pretty well. We potted it in our usual hard black epoxy, and shipped it to a customer in Connecticut—a customer of Larry Plante who was our Sales Engineer for that region.

Also, I sent in a Patent Application to our patent attorneys. I forget exactly who it was. Was it Curtis, Morris, and Safford in New York, or was it Schiller and Pandiscio in Waltham? No matter.

That must have been a busy year, because by the time I got off the other hot projects I had to work on for a number of high-priority customers, I realized I hadn't heard anything from this customer in Connecticut. I got in touch with Larry Plante.

All he knew was that the customer didn't like it. Worse yet, a whole year had elapsed since I had sent the part in interstate commerce, and the patent attorney had done nothing, so the patent application was now worthless.

I was quite cross, and I read the Riot Act at those attorneys. Then I set in at the workbench with a vengeance. And that led to the 4701 Voltage-to-Frequency Converter, which I'll tell you about in the next issue's Pease Porridge column.

All for now. / Comments invited!  
RAP / Robert A. Pease / Engineer

Address:  
Mail Stop D2597A  
National Semiconductor  
P.O. Box 58090  
Santa Clara, CA 95052-8090

#### References:

1. "Analog Circuit Design: Art, Science, and Personalities," edited by Jim Williams, 1991. 398 pages. Butterworth-Heinemann, Boston, Mass., (800) 366-2665. About \$51. An excellent book; you should have your librarian order it.

# PICO

## Multiplex Data BUS Pulse Transformers **MIL-STD-1553**

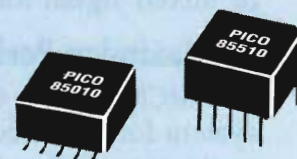

Actual Size  
**.4" x .4" x .2"Ht.**

- **Surface Mount**
- **Plug-In**
- **QPL Standards  
MIL-T-21038/27C**
- **MIL-STD-1553**

These pulse transformers manufactured to MIL-STD-1553 COMMAND/RESPONSE MULTI-PLEX DATA BUS requirements. They also are manufactured to MIL-T-21038/27C specifications and are designed to meet MAC AIR SPECIFICATIONS A3818, A5690, A5232 and A4905.

All of these transformers exhibit superior electrical performance. Common mode rejection ratio is greater than 45dB at 1 MHz. Input impedance is greater than 3000 ohms over the band from 75 kHz to 1MHz at 1V rms. This series possesses exceptional waveform integrity: Rise time and fall time is less than 100 nanoseconds. Overshoot and ringing is less than  $\pm 1V$  peak. Droop is less than 20%.

Delivery—  
stock to one week

See EEM  
or send direct  
for **Free PICO Catalog.**  
Call toll free **800-431-1064**  
in NY call **914-699-5514**  
FAX **914-699-5565**

**PICO Electronics, Inc.**

453 N. MacQuesten Pkwy., Mt. Vernon, N.Y. 10552  
READER SERVICE 232



# WHAT'S ALL THIS V-F CONVERTER STUFF, ANYHOW? (PART II)

If you have already read Jim Williams' compilation, "Analog Circuit Design: Art, Science, and Personalities,"<sup>1</sup> then you may look on this column as a summer rerun. However, several people, after reading my 1993 comments on Frequency-to-Voltage converters, asked my opinions on Voltage-to-Frequency Converters. I realized I had written all this down already, so here is a serialized version of the chapter I wrote in Jim's book—reprinted with the kind permission of Butterworth-Heinemann, Boston, Mass. Meanwhile, I'm going hiking.—RAP



**BOB PEASE**  
OBTAINED A BSEE FROM MIT IN 1961 AND IS STAFF SCIENTIST AT NATIONAL SEMICONDUCTOR CORP., SANTA CLARA, CALIF.

I realized that my original circuit had depended on the power-supply magnitude for its Gain Factor. So, it had no power supply rejection, or, to be more nearly correct, it had a PSRR of about 0 dB. So I added a Zener in a bridge to create a PSRR of perhaps 45 dB. (Note, that was the first time I had ever seen such a Zener bridge—was I one of the earliest inventors of that circuit? It's a neat and useful circuit.) I also added improved features around the amplifier itself to improve the startup and the accuracy. I re-

placed the (sole-sourced) 805BE with the more popular and inexpensive LM301A.

I gave the breadboard to my technician, Dick Robie, to oven it and graph out the tempco from the temperature data. That night, when I was on the way out the door, I stopped and asked Dick what had he seen for the tempco. He replied, about zero. I asked, "Whaddya mean, zero. You mean, down near 100 parts per million per degree C?" He replied, "Oh, much better than 100—less than 10 ppm per degree C."

I was shocked. How could it be that good?? The next day, I figured out the fortuitous situation: For the "charge-dispersing capacitor," I had, of course, used one of the best capacitors in the house, the most precise and stable ones, which were polystyrenes with a tempco of  $-110 \text{ ppm}/^\circ\text{C}$ .

This tempco was just about can-

celled out by the tempco of the entire group of diodes in the rest of the circuit. Namely, the driven end of the capacitor moves about 12.4 V p-p, plus the  $V_f$  of 4 diodes.

These 4 diodes run rich at about 6 mA, and have a tempco of about  $-2.0 \text{ mV}/^\circ\text{C}$ . The peak-to-peak voltage of these 4 diodes is approximately cancelled by that of the other four  $V_{be}$ s at the other end of the Polystyrene capacitor, but those diodes run at about 0.1 mA, and their tempco is about  $-2.3 \text{ mV}/^\circ\text{C}$ .

The difference of these is about  $4 \times 0.3 \text{ mV}/^\circ\text{C}$ , or  $1.2 \text{ mV}/^\circ\text{C}$ , which is about big enough to cancel out the  $-110 \text{ ppm}/^\circ\text{C}$  of the capacitor. Now, there were several things I could have done to fix it if the tempcos hadn't come out even. For example, I could have used 3 diodes, or 5, or  $4 \frac{1}{2}$ , or  $3 \frac{1}{2}$ , but if 4 was the right answer, I'd go with it.

Now, how DOES this Kluge Work?? The best way for me to explain how the 4701 V-to-F Converter really works is for you to trust me, and assume that it really does work. After we analyze each section of it, then you will agree that was a reasonable assumption.

First, let's assume that the  $-$  input of op amp A1 is a few millivolts more negative than the  $+$  input, and that  $V_{in}$  is some positive voltage. Rather

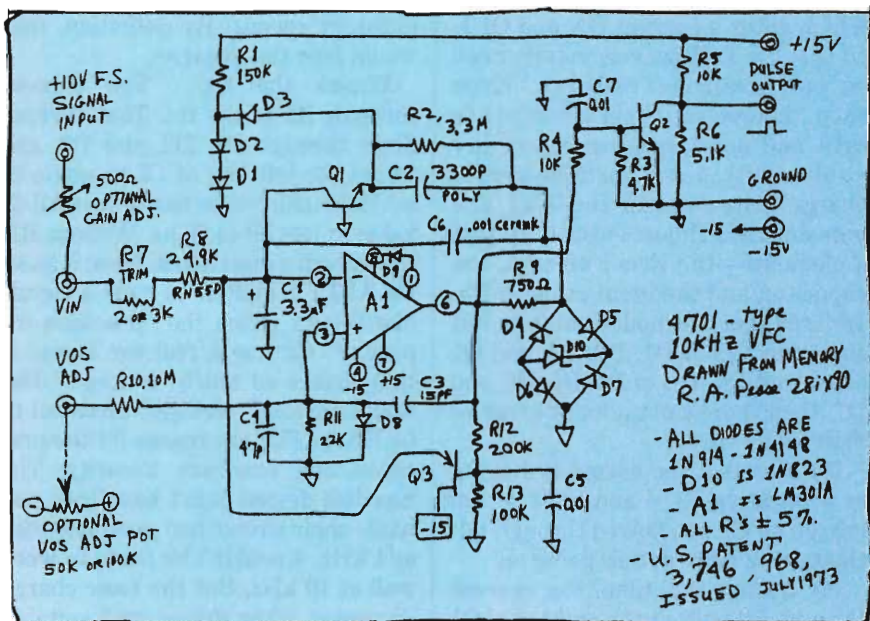



# PEASE PORRIDGE

soon, the voltage at the - input will cross over and exceed that of the + input. Now, during this time, A1's output has been at the + limit, near +13 V. But when the inputs cross, the output will rapidly slew to -13 V. What are the interesting things happening then?

(1) Because there's positive feedback through C3 = 10 pF, the + input is driven a few volts negative. This ensures that there will be a good wide healthy pulse—at least 17 or 21  $\mu$ s.

(2) The right-hand end of C2 is driven from about +7.5 V to -7.5 V, and the left-hand end of C2 is discharged through the emitter of Q1. That's a specific amount of charge,  $Q = C \times \Delta V$ . And the  $\Delta V$  isn't just the 15 V p-p at the right-hand end of C2, but rather it's that 15 V p-p *minus* the 2.5-V p-p excursion at the left-hand end. When this charge is driven into the emitter of Q1, it comes out of the collector (well, at least 99.5% of it does) and pulls the voltage on the 3.3- $\mu$ F capacitor down by about 12 mV. During this time, the voltage at the + input of A1 is much more negative than that, so this step of -12 mV is just a minor jump. But, that charge is the magic element of precision. You see, the size of the 12-mV jump isn't important, but the amount of *charge* is.

Note, in most conventional V-to-F converters, the charge is dispensed by a timer circuit such as an LM555, which gates a current ON and OFF, so  $Q = I \times T$ . However, you do need several precision resistors. Even then, though, the timer is subject to drift and noise, making it a rather crude, drift, noisy, unstable kind of charge dispenser. In the 4701, the gain depends almost entirely on just 3 elements—the Zener voltage, the capacitor, and the input resistor R8. It's true that the diodes enter in, but since the  $V_f$ s of D1, D2, D3, and Q1 cancel out the  $V_f$ s of D4, D5, D6, and D7, then there's not a lot of error or drift likely there.

(3) Now that the output is staying at a negative 13 V and most of the charge on C2 has flowed through Q1, there are 2 more details going on:

(a) During this time, the current through R2 pulls at the emitter of Q1

and makes sure that Q1's emitter settles at a stable voltage. It makes sure that Q1's emitter voltage doesn't tail off to some drift, voltage. Even though R2 looks like it will dump in current that would hurt precision, it actually helps the precision. Even though a precision capacitor used in a precision VFC would normally not have a 3-M $\Omega$  resistor across it leaking like crazy—this circuit thrives on *exactly* that “leakage”—because it makes the emitter voltage settle to a consistent level.

(b) The voltage at pin 3 of A1 ( $V_3$ ) is tailing up gradually to be more positive than the voltage at pin 2 ( $V_2$ ). After all, pin 2 was pushed down 12 mV. Soon, after about a total of 20  $\mu$ s,  $V_3$  will cross  $V_2$  and the output will bang back up to +13 V.

(4) Okay, now finally  $V_3$  crosses  $V_2$  and A1's output goes positive. We have to wait for the current through R8 to pull  $V_2$  up the 12 mV that it was pushed down. That time will, of course, depend (inversely) on the size of the signal input; the bigger, the faster. That means the time between pulses could be anything between 90  $\mu$ s and 9 or 90 ms.

Are we forgetting something? Yes. The peak-to-peak voltage at the left end of C2 must be stable and constant and invariant of rep rate. But the diodes there might give a long tail—the voltage might settle gradually and give a different peak-to-peak value at different speeds. By definition, that would hurt the linearity.

What's the fix? The current through R2 is the fix. That current flows through D1, D2, and D3, and forces the left end of C2 to settle to within a millivolt or two of its final dc value in just 50 or 60  $\mu$ s. Without R2, the linearity goes to pot. Now, it looks **REALLY STUPID** to have a circuit like this in which the “precision capacitor” C2 has a resistor across it that makes so much “leakage.” But that controlled “leakage” turns out to be **EXACTLY** the reason for the precision and excellent linearity. The Swedish design didn't have this, and while their circuit had good linearity at 1 kHz, it couldn't be made to work well at 10 kHz. But the basic charge dispenser, when driven with suitably

fast transistors, works well at 100, 1000, and even 5000 kHz.

What else is in the circuit? D8 is needed between pins 1 and 8 of the LM301A to keep it from wasting excessive current in its - limit. D9 works well to protect the + input from overdrive in the + direction. Q3 functions only when you overdrive the input—let's say, pull  $V_{in}$  up to +50 V—and put in so much current that the VFC stops. Then it stops with pin 2 of A1 at +1 V, and pin 6 at -13 V. It would never put out another pulse. It would never restart, even if  $V_{in}$  falls to a legal level, such as +1 or +5 V. However, we have added Q3. So, after a lag, C5 gets pulled minus, and Q3 turns on and pulls pin 2 so low that operation does start again. In normal operation, Q3 just sits there and does nothing, biased OFF.

C7 acts as a pulse stretcher. The pulse width at the output of A1 is about 22  $\mu$ s. But we had a companion F-to-V converter, the 4702, that could only accept 20  $\mu$ s (or wider) pulses. If A1's output pulse got any narrower than 20, the 4702 would lose accuracy. We solved the problem by putting in C7. Therefore, when A1 makes a 20  $\mu$ s pulse, the base of Q2 would be held off a little longer than that due to the RC lag—about 15  $\mu$ s extra. Then a 4701's pulse was always plenty wide enough to drive a 4702.

The little capacitor C6 was added to make the peak-to-peak voltage at  $V_2$  a little bigger. So, when some LM301's were a little slow, there was now a bigger signal between  $V_2$  and  $V_3$ , and the amplifier wouldn't balk. After all, the LM301 is characterized as an operational amplifier, and if some are a little slower than others when you run them as a comparator, you really can't complain....

As you can see, the 4701 circuit did get a couple of band-aids, but not too many, and we never really did get stumped or stuck in production. Our customers loved the linearity, the tempo was pretty good, and the frequency output would never quit. The customers figured they really got their money's worth, and I certainly couldn't disagree with a satisfied customer.

I got my boss, Dave Ludwig, to ap-

**FREE ISSUE!**

Let us deliver  
the world of  
**Electronics**  
to your desk

The global electronics  
executive's indispensable  
source for industry  
news, trends and  
analysis in key markets:

- Telecommunications
- Semiconductors
- Computers
- International Trade

**YES!** Send me my **FREE** issue of **ELECTRONICS** and enter my 1-year subscription, 23 issues—for **10% off the regular subscription rate!** If I choose not to subscribe, I'll simply write "cancel" on the invoice and return it. The free issue is mine to keep.

**One year subscription rates:**  
(U.S. funds drawn from a U.S. bank)

- U.S. ~~\$98~~ \$88
- Canada ~~\$120~~ \$108 (plus GST)
- Other Countries ~~\$190~~ \$171

Please bill my credit card:

- Visa     MasterCard
- AMX     Discover

Card No. \_\_\_\_\_

Exp. Date \_\_\_\_\_

Signature \_\_\_\_\_

Date \_\_\_\_\_

Name \_\_\_\_\_

Title \_\_\_\_\_

Company \_\_\_\_\_

Mailing Address \_\_\_\_\_

Order by FAX: 216/696-6413  
or call 216/696-7000, x 4137

## PEASE PORRIDGE

prove the layout of a printed-circuit board, and I think Wayne Norwood was the guy who laid it out. We built up a few dozen and evaluated them thoroughly. I wrote up a draft of a data sheet, and I negotiated with Skip Osgood and Bill Bernardi to get it printed properly. I made up some test equipment and we got a silk screen for the module, and we called it the 4701. We were in the Voltage-to-Frequency Converter business.

To this day, I don't recall exactly how we got these V-to-F Converters to be so popular. I can't recall how we found so many customers, or how we publicized the VFCs. I asked Frank Goodenough because I knew he had been involved. He recalled that he had looked at some of the characteristics of this 4701, and he suspected that a good V-to-F Converter might be useful at The Foxboro Company, the big process-control experts. Indeed, he did find some interest there. The company was very interested, but it never bought very many because they wanted to buy only parts available from multiple sources.

The 4701 became popular, with many customers at many companies. It became profitable. It became good business. If I had all the time and space in the world, I would tell you how the 4701 led to the 4702 (a 10-kHz F-to-V Converter using the same charge-dispensing principles) and the 4703 (100-kHz full-scale VFC) and the 4705 and 4707 (1-MHz and 5-MHz VFCs). Also, the 4709, 4711, 4721, and 4715 VFCs, and 4704, 4706, 4708, 4710, and 4722 FVCs. Some of these had a moderate tempo of 150 or 44 ppm/°C, but some were well-trimmed and guaranteed to 6 ppm/°C—as good as the best DVMS of the day.

But it all started with that crummy little 4701—and the principle that one cheap operational amplifier driving a little charge dispenser could make a very linear data converter. This came from an understanding that you could build an oscillator with a UJT and an operational amplifier to help improve the linearity, and *then* throw out the UJT!! I was able to do that because I was receptive to the concepts that would make a good Voltage-to-Fre-

quency converter, even though I had never seen a Voltage-to-Frequency converter!

I was able to make accurate measurements, to throw in precision components—Zener references, capacitors, resistors—and to get inexpensive IC amplifiers, and to optimize the whole little system. What's the lesson for us to learn?

I like to think of the words of Branch Rickey, manager of the St. Louis Cardinals in the 1920s (and later manager of the Brooklyn Dodgers). One of his favorite sayings was "Good luck is the residue of design." When he referred to his baseball teams, he meant that his players were able to handle any play, field the ball, throw to the right base, etc., no matter how surprising the bounce of the ball might be.

If his players had learned the fundamentals, if they were prepared for any situation, they could take advantage of game situations and WIN. Other people might say his players were just lucky, but he knew darned well that he had trained them and drilled them so they would instinctively know to do the right thing.

I, too, was in a situation where I was prepared to take advantage of the opportunity, and I didn't drop the ball when it came my way. (Well, I fumbled it for a while but then I got it right.) That's the point of this column: When somebody hands you a gift on a silver platter, you really must be prepared to recognize it.

All for now. / Comments invited!  
RAP / Robert A. Pease / Engineer

Address:  
Mail Stop D2597A  
National Semiconductor  
P.O. Box 58090  
Santa Clara, CA 95052-8090

References:

1. "Analog Circuit Design: Art, Science, and Personalities," edited by Jim Williams, 1991. 398 pages. Butterworth-Heinemann, Boston, Mass., (800) 366-2665. About \$51. An excellent book; you should have your librarian order it.

## PEASE PORRIDGE



# BOB'S MAILBOX

### Dear Bob:

I enjoyed your February 7, 1994 column about the testing controversy. I helped to develop a very sophisticated microwave instrument when I worked for the High Priced company. It sold for about \$45,000 at the time (and is over \$60,000 now). The instrument was very complex, so every unit was placed in a burn-in chamber for a week.

The production manager, ever searching for a way to maximize profits, saw all of this finished goods inventory sitting there, wasting floor space and representing \$\$\$\$ that were not flowing into the corporation in a timely manner. So he decided that this burn-in would no longer be required.

Luckily, we kept data (failures, test data, etc.) on all of these instruments, so I was able to show that each and every instrument failed at least once during the burn-in period! Because the standard warranty period for the instrument was one year, I was able to show that it cost the company less (due to warranty costs) to burn-in the instruments than to eliminate the tests. And we had a lot fewer unhappy customers. Logic and the bottom line prevailed when I showed this data to the division manager. (The production line was not charged for warranty costs in the accounting system, so the production manager did not see these costs in his budgets.)

The moral of this story is that complex instruments fail in complex ways, and that it is important for the manager that produces the unit to be charged for the problems.

We also used the failure data to redesign some circuits when a design problem could be identified. Many problems appeared to be simply random component failures. (If a million 1- $\Omega$  resistors were placed in a series combination, and if the failure rate of each resistor were  $1 \times 10^{-6}$ , what is the failure rate of the resistor string?)

**LARRY MARTIN**

*Larry Martin Consulting  
Sebastopol, Calif.*

*Gee, did Mr. Deming ever decree, "Thou shalt not burn-in your equipment before final test?" I don't think so! If those 1- $\Omega$  resistors tend to fail short, that's not so bad. If they fail open, you'll be busy trying to keep that resistor working!—RAP*

### Dear Robert:

"Floobydust." I first saw that word sometime in the early 1970s. It was used in one of National's application manuals. I plowed through my library and came up with *Linear Applications, Handbook 1*, dated 1973, and *Linear Applications, Handbook 2*, dated 1977. The 1973 book is rather battered, worn, and wrinkled. The pages are yellow and marked here and there with notes written in red. The 1977 book also is beat up, but the pages are still white—a better quality paper. Sitting adjacent to Handbook 1, on its right side, used to be an application manual that concerned itself with audio. In 1978, I made the mistake of loaning the book to a kid just coming along. Always a mistake, because loaned books are lost forever. In any case, the word FLOOBYDUST was used in that book as the title of the section describing various signal distortions that could be induced, and the circuits used to create those effects.

I'll probably never have a use for that book again, but it is imperative that I have it in my library. So, if you search the archives of National and come across the book, I would certainly appreciate receiving a copy if one is available. (Actually, you can never tell. A couple of weeks ago, I had occasion to look up some data concerning a 6SN7 in the *RCA Receiving Tube Manual*, circa 1950.)

While I'm at it, I've been trying to drop you a note for some years now concerning one of the helpful troubleshooting tricks described in your series on analog whatever. I remember your suggestion of shunting points in physical circuitry with handheld radial capacitors. Well, sometimes oxidation

prevents electrical contact at the end of the leads and whatever it is you are trying to shunt. It is best to take a pair of cutters and cut the leads at a sharp bias, say 60 degrees. This puts a sharp point on the end of the leads, and very effectively pierces any insulating coating that may exist. Blood is very corrosive, so care is required. When not in use, the capacitors can be stored with the end of the leads pushed into a cork. That's a good storage device for test leads employing steel phonograph needles in chucks as probes. I wish I could find some of those probes. Maybe you'll come across a couple of those while searching for the Manual, if you decide to look.

**PETER L. KROHN**

*Easton, Pa.*

*I agree, old books are valuable, and hard to keep track of. I'll send you a photocopy of the old Audio Handbook for your library. Yes, a capacitor with its leads cut diagonally does make a better probe than other components. I have a collection of old corks for that use, too.—RAP*

### Dear RAP:

I purchased a "GreenPlug" for my refrigerator and I am very pleased with the improvement. The refrigerator runs quieter and the automatic icemaker works better than ever.

Supposedly, it is based upon NASA technology (whatever that means). I suspect it is a simple filter, or a circuit based on fuzzy logic, etc. Could you enlighten me on its operation? Does it *really* save electricity? Outwardly, the claims seem too good to be true, but it is doing something.

I have a difficult time believing a device so inexpensive (less than \$30) works so well. I would appreciate your comments, and perhaps a solicitation of comments from others who have used the GreenPlug.

**KEN McRAE**

*Bellevue, Wash.*

*I've been hearing about the NASA circuits for a long time. They couldn't*



# PEASE PORRIDGE

*make it work 20 years ago; maybe now they finally got it working. Ask the manufacturer for a copy of the report from the independent testing lab, which will prove that it saves you energy and money at high line and low line. Or, wait to see what "Consumer Reports" says.—RAP*

## **Dear Bob:**

I just read your "What Is All This Apples and Oranges Stuff, Anyhow?" article in the May 2 issue. Amen.

I think the best example of the problems of JIT for the electronic industry, and how 3- or 6-month lead times for ordering is shooting it in the foot, is my recent attempt at getting a small quantity of a part for personal use.

I got a flyer from a company (not NSC) talking about a new ADC. It would be perfect for a project I was thinking about working on, if I could only find a cheap, simple 12-bit ADC that talked to the Motorola 68HC11 without a lot of brouhaha. This part did it all for about \$20.

I called the distributor. No, sorry, none in stock, three months lead time. I called several places, such as Digikey. No, sorry, none in stock, three months lead time. Well, most of the time, if I had to wait three months before I work on a project, that project doesn't get worked on, and I did want to try this one. I called the manufacturer. They surely could sell me three of the parts.

No, sorry, none in stock, three months lead time. BUT they forwarded my call to the samples department. Sure, two pieces for free as samples, no problem.

What a wonderful system. Here I was ready to give someone money for something and I couldn't get anyone to take it. If only the IRS worked on JIT. A company is actively advertising its products, but was not planning on having any ready to sell for the next three months. Amazing.

This is not the first time I have run afoul of long lead times and ADCs. That was many years ago when I blew up the only 12-bit ADC I had on hand, and learned it would put my PhD research back 6 months waiting for another. What I learned from that was that an 8-bit DAC and a comparator, along with some small bit of software, makes a dandy

successive-approximation ADC, and that systems with enough noise don't need the extra four bits anyway.

**JOHN STANLEY**  
**Corvallis, Ore.**

*IC availability comes in only two flavors: the parts are available and the customers aren't, AND vice versa. Sigh.—RAP*

## **Robert!:**

I was delighted with your Pease Porridge feature in the May 2 issue of *Electronic Design*. Our country is awash in wannabe educators who believe simplified approaches are warranted...lest we overstress the student's gray matter and turn 'em off. About 1/3 of the way through your article, I was thinking "I need to send Bob a copy of *The Goal*..." I could not have been more pleased to read your recommendation of this fine work later in the article.

You've reinforced a growing concern I have about our passion for simplistic models of complex systems. Case in point: Our government is spending billions in public and private money ostensibly for the enhancement of aviation "safety." An ongoing endeavor is to electronify the task of keeping airplanes from getting together in mid-air. This event is so rare statistically that rational analysis of cause and effect is very difficult. Taken as a whole, if two airplanes munched together every day, you'd still have to make a flight a day for years before standing a good chance of being an attendee at a disaster. (OOPS! Pardon my simplistic model.) The causes are so variable and intertwined that taking control of independent variables is virtually impossible.

Nonetheless, we *will* have some form of warning system in the cockpit. Pilots will report making all kinds of evasive maneuvers as suggested by the squawking device on the panel. Obviously, each action will narrowly avert a disaster so that politicians will deem the project a grand success and justify expenditures. However, I suggest that pilots will (1) become complacent and abrogate yet another pilot responsibility (keep your head up and eyes open) to a black box, and (2) become tired of making so many evasive maneuvers and begin to ignore the

equipment. In any case, the newcomer to the cockpit will become yet another distraction and raise, not reduce, the probability of disaster.

Many people trust the ability of news "analysts" and politicians to pass judgment upon cause and effect based upon no science, no hard data, and, therefore, no real analysis. Risk assessment is never a part of the thinking. We'll spend billions (to save a human life or two) and accomplish little or nothing in aviation, while failing to spend a few millions on roads and bridges which would probably save many, many more lives.

I am working with an ad hoc consortium of designer-analysts to propose a very economical application of emerging technologies (GPS and gigahertz communications products) to give pilots a situation display in the cockpit that keeps a gray-matter CPU in the loop and the FAA out of the loop. The problem has been to get the government's sincere attention. They want to build more equipment, hire more people, and spend more money...not less!

So you see, Bob, fuzzy logic isn't really new. Clergy and politicians have practiced it for centuries. Business schools have only become infected in the past few decades. Your reference to old formulas and cookbooks gives them too much credence. The word "obsolete" implies validity in times past; many such crutches were never valid. Thank you, sir, for being a good observer, doing sound analysis upon observations and having the courage to write about it in the face of authority.

**ROBERT L. NUCKOLLS III**  
**AeroElectric Connection**  
**Wichita, Kans.**

*I still think technology may help prevent certain types of aircraft collisions. But keeping your eyes peeled and your neck swiveling is still the best defense.—RAP*

All for now. / Comments invited!  
RAP / Robert A. Pease / Engineer

Address:  
Mail Stop D2597A  
National Semiconductor  
P.O. Box 58090  
Santa Clara, CA 95052-8090

# WHAT'S ALL THIS ELECTRIC CAR STUFF, ANYHOW?

A few weeks ago I read a letter (published in *EE Times*) by our old friend, Jim Hansen of New Boston, N.H. He presented several reasons why an electric car would have problems achieving great popularity, even though several states have passed laws mandating that cars that make zero pollution, must be made available, for us to buy. If an electric car is to be made efficient, it must be very light yet very strong, he observed. This typically leads to a fairly fragile structure, which is not only expensive, but, if you get into one little accident, it is liable



**BOB PEASE**  
OBTAINED A  
BSEE FROM MIT  
IN 1961 AND IS  
STAFF  
SCIENTIST AT  
NATIONAL  
SEMICONDUCT-  
OR CORP.,  
SANTA CLARA,  
CALIF.

to be bent and crumpled and not repairable. One ding and it is smashed. These will not be inexpensive cars to own, when they start having accidents. Also, he observed, an electric car is made of exactly the kind of materials (high-current batteries, bus bars) that one would use to make a welder. In case of an accident, the arc-welding begins.... Not a fun place to be in an accident. Also, if the battery cases crack, there will be battery acid all over the street. Messy. And what if there is an electrical breakdown in the control computer? You might have a healthy motor, and healthy batteries, but you still couldn't get home. And in cold

weather, how do you run the heater? In hot weather, are you supposed to do without air-conditioning?

I sat down and started writing to Jim. The problem of welding can be solved if suitable fuses are built into the bus-bar paths. The problems of acid leakage might be alleviated if suitable neoprene or rubber or plastic bags surround each battery. Not all would be cut after an accident occurs. Also, packages of alkalines or buffers could be provided, to neutralize spills. As for the computer failure, you might be able to get a limp-home mode, when the primary controller/computer poops out.

Then I pointed out to Jim, none of these reasons are enough to cause me to not buy an electric car. Heck, I only commute 44 miles in the morning, and the same at night—not a big deal. But, while the initial cost of the batteries is bad enough, the cost of replacing them every 30,000 miles is significant, since I put on that many miles every 15 months. Many promoters of electric cars ignore or gloss over the costs and problems of finite battery life. They say their operating costs are only 3 or 4 cents per mile, much better than a "typical" gas-powered car at "8 cents per mile." Well, I sure as heck do not pay 8 cents per mile to run my VW to work. Maybe 5 cents per mile, including replacing the engine every 230,000 miles, whether it needs it or not.... If I bought an electric car and it saved me 2 cents per mile, I would have to run it for 20 years to break even, not to mention, get ahead on costs. No, the cost of replacing the batteries periodically, is a significant factor in keeping me from buying an electric car.

Then I commented on the heater problem. You could easily rig a little

propane heater, as an add-on accessory. That would keep your feet warm, and your windshield clear for all cold weather. BUT I have done a LOT of driving in Massachusetts. Often, I would drive to work, and the snow would begin, and by the time I wanted to go home, the highways would be 70% clogged with snow, and 80% clogged with stalled cars. You would just KNOW that you could not start out on a trip of 30 miles in conditions like that, in a battery-powered car, and have any serious hope of getting home. So, in some parts of the country, an electric car would just be trouble looking for a time and place to happen.

Then I began to muse about some of the rule-benders that my friends knew, back in Taxachusetts. When you buy a car there, first you pay Sales Tax on it, once, and then you pay "excise tax" on it, annually, forever. If you buy a car with a built-in radio, you pay excise tax on the radio forever, too. So a number of my friends would buy a car with no radio. Then they would buy a good after-market radio, and they would be able to avoid paying excise tax on the radio, forever. Maybe such a person would buy an electric car without a radio—and without a heater. Then after he gets it registered, he could drive down to Lechmere Sales and buy an after-market radio—and an after-market heater. That way he could have a perfectly non-polluting car—but a bolt-on, modular heater. Of course, the car would have to be designed to accept a modular add-on heater, air vents and controls, too. Well, that is a neat solution to that problem. Now, does that suggest anything else?

Well, yes, it does. I think I would like to buy an all-electric, non-polluting, battery-powered car, and then drive down to Lechmere, and buy an add-on, after-market gasoline engine, or maybe a propane engine, or a diesel engine, that I could use to re-charge the batteries. This would be a bolt-on engine-generator set, so any time I wanted to remove it, I could prove that I still had a pure, non-polluting electric car. But when I wanted to go on a long trip, such as to work, I would start down the street, and as I neared



**Our  
Power Module  
is Dual...  
theirs is only  
single output!**



Patent Pending

- **Low Cost DC-DC Converters**  
Single Outputs \$104 /  
Dual Outputs \$149
- **Dual Isolated Outputs**  
28 Standard Models /  
Special Voltages Available
- **Wide Input Voltage**  
Four Series / 18-380 VDC Input
- **Parallel Operation**  
Fixed Frequency 100kHz  
True Redundancy Operation
- **100 Watts**

The availability of DUAL ISOLATED OUTPUTS creates cost and space savings in many applications. Fully safeguarded for over voltage, over temperature and continuous short circuit protection, these FIXED Hi-Frequency units minimize technical problems. With output voltages from 3.3 VDC to 100 VDC, four distinct input ranges and the choice of single or dual outputs plus the capability of Parallel Operation, as standard features, your circuit designs can be optimized. Assembled in the U.S.A. with PICO quality components, these hi density units allow the most stringent mechanical, electrical and environmental requirements.

See EEM or send direct  
for **Free PICO Catalog.**  
Call toll free **800-431-1064**  
in NY call **914-699-5514**  
FAX **914-699-5565**

**PICO Electronics, Inc.**

453 N. MacQuesten Pkwy., Mt. Vernon, N.Y. 10552

READER SERVICE 182

108

ELECTRONIC DESIGN

AUGUST 8, 1994

## PEASE PORRIDGE

the freeway, I could start the little engine, and all the way to work, I could keep feeding charge to those batteries. If I got to a traffic slowdown, the batteries would just get better and better charged. As soon as I got to work, I could just leave the engine run a few minutes, and when the batteries got charged up, the engine would shut off automatically.

Hey, now there is a rule-bender! Even better than not having to pay excise tax on your radio, and your heater, and your engine, forever, you could drive a non-polluting car, and charge up the batteries when they needed it, and not discharge the batteries very much. Better yet, you could get along with 1/2 or 1/3 or 1/4 as much batteries as usual. And best of all, the batteries would never get discharged very low because you could keep feeding them charge. So, the batteries get MUCH lighter, and the battery never gets cycled low, so, battery life would be GREATLY increased. And all I have to do is find a modular 5 HP motor-generator... because I know that a VW can cruise at 55 mph, on the flat, with no headwind, using just about 5 HP. That's about 10 x as much power as the cute little portable motor-generator sets. So, I will have to shop around for a suitable, compact engine-generator set.

Now, while every internal-combustion engine does generate some pollution, an engine designed to run at constant speed and constant load can be designed to run *much* more cleanly than an engine that has to be able to run at light or heavy loads, and at slow or fast speeds. So this car, while not as clean as a car whose batteries are recharged by wind-power or hydro power, can still be a lot cleaner than most gasoline-powered cars. Still, now there is no technical reason I cannot use a "battery-powered" car. Of course, the concept of this "hybrid" car has been around for many years—but, the modular approach seems to bring some new advantages.

Then my brain began to race—maybe I can patent this? I phoned my friend Al, in the Intellectual Property group. I asked him to run a search on this concept—a *modular, removable* engine to go in an electric car. Wow! I

could be a hero!! I could be RICH!!!

The next morning, Al showed me a 1993 patent, U.S. patent number 5,225,744, for an electric car with a modular, bolt-in engine, by a couple of Japanese engineers.<sup>1</sup> Well, I had a good idea, but these guys only beat me to it by 3 or 4 years. Sigh. Still, it is a good idea, even if I have to pay royalties to these Japanese guys. They deserve it. So, one of these days, a battery-powered car may indeed be really practical. Even if the snow slows you down, the little engine can keep the battery charged. You would be able to get home—*without* running your batteries down. Worst case, you could stop for coffee, and leave your motor-generator running.

Finally, I threw in one more idea to tickle Jim's fancy. There are some new flywheel modules made by Flywheel Systems, (Seattle, Wash.) that weigh 40 lb, and spin a carbon-fiber rotor up to over 100,000 rpm. When you put 20 of these magnetically-coupled flywheel modules in your car, you'll have enough energy to drive as far as 390 miles. (Estimated, best case.) Admittedly, these flywheels are just in the prototype stage, but they really do have a lot of advantages over batteries. They can be "recharged" many, many times, and you can draw a lot of power out of them without straining their longevity. They are easy to arrange to be modular in parallel, so if one or two quit, you have 19 or 18 to keep you going. Maybe if I combined those with a little 5 HP engine, I would need only 2 or 3 flywheel modules...??? Maybe if I wait just a little longer, I can get all these advantages, without having to design and build the car myself... So, Jim, it sure sounds like fun, in the not-too-distant future.

All for now. / Comments invited!  
RAP / Robert A. Pease / Engineer

Address:  
Mail Stop D2597A  
National Semiconductor  
P.O. Box 58090  
Santa Clara, CA 95052-8090

1. U. S. Patent 5,225,744: Masami Ishikawa and Yukihiro Minezawa; assigned to Aisin Aw Co., Ltd., Japan. Filed April 27, 1991; issued July 6, 1993.



## PEASE PORRIDGE



# BOB'S MAILBOX

*Dear Mr. Pease:*

We are a garage operation startup that has just received a federal SBIR (Small Business Innovation Research) phase I grant to develop and evaluate several nontraditional tactile imaging sensors. Our literature search turned up two old magazine articles authored by Dudley B. Clark, Clark Electronic Labs, Palo Alto, Calif. In them, Mr. Clark talks about his proprietary piezoresistive pressure sensors that have a world of desirable features, e.g. large dynamic range, good resistance to overpressure damage, little hysteresis, low (and linear) thermal drift, little aging drift, good sensitivity and repeatability, lots of output ranging options, etc.

The implication is that the materials employed change their fundamental resistivity when loaded (stressed). If true, this is quite different from those sensing technologies which depend on changes in internal connections, path length, and/or cross-section. Such sensors seem almost too good to be true.

Clark said that his sensors were made of intermetallic "plastic" materials composed of zirconium tetrachloride and rare earths (presumably scandium, yttrium, and the lanthanide series elements or their compounds). I would like to include evaluation of Clark's technology as part of our SBIR if more information can be obtained from Mr. Clark, his associates, his firm, its successor, or any other source. Unfortunately, time is short.

So far, I cannot find hide nor hair of D.B. Clark or his firm. As you might expect, the publishers of the magazines have no records dating back to the '50s and '60s.

If you or any of your readers can shed any light on this subject, I can be reached at (612) 881-2824.

**D. CAMERON SMITH**

*The Oxboro Technical Group Inc.  
Bloomington, Minn.*

*Does anybody know the whereabouts of Mr. Clark? Or where his technology may reside?—RAP*

*Dear Bob:*

I was pleased to see your column in the May 2 issue about the oversimplification that is so often seen in the JIT process. Let me tell you my experience.

I started with a major instrument manufacturer in Beaverton, Ore., in 1977. During that time, it was difficult to get parts. They either couldn't get the inventory they needed, or couldn't efficiently distribute the inventory to where it was needed. So, in the early '80s, they built an "automated warehouse" with a vast capacity for components in computer-picked storage bins. They got the process up and running, and eventually perfected their component delivery system. Then they got the JIT religion. A few years later, they held an auction to try to sell off a large number of assets (reducing staff from about 25K to 8K left them with a lot of extra stuff). As I recall, nobody even put in a bid for the storage system.

It is possible that the high-level people understand the complex factors involved in optimizing inventory. But the low-level people who actually buy the parts do not. A plastics manufacturer was saying that he sells them a small part, a year's supply of which would fit in the palm of your hand and cost 5 cents each. Instead they insist on buying these parts a week's supply at a time at 50 cents each. This JIT is not costing them "a little bit more," but "A LOT MORE," at least on some items. It has been suggested they buy through distributors, who would hold stock for them at little additional cost. But that is contrary to the JIT religion, so they won't do it.

The problem with the JIT method is that it compromises profit margins forever, or at least from the moment JIT is implemented until it is abandoned. Every year, those higher JIT materials costs cut into the gross margin. Tightening inventory through JIT releases cash from the balance sheet only once, as a one-time event occurring at implementation of the

JIT program. From then on, JIT impairs profitability every month of every year. Only a very shortsighted management team could expect to prefer a one-time cash-flow boost over long-term income statement profits.

Since then, I've started a small company, and our inventory decisions are not based on religious zeal. We consider our usage rate, how long it will take to get additional stock, physical size of the part, quantity pricing discounts, availability from alternate sources, item cost and margin, and whether this is a critical part of a larger system versus a minor accessory.

If sales shoot up, we can build up and ship from stock until replacement materials arrive. If sales are slow, well, we have some money tied up in inventory. But I would rather we make continuing profits from sales of product (which leads to repeat sales, larger market share, and a more stable income stream), than from manipulating inventory to extract cash once (which leads to inability to meet demand, and loss of sales).

When we introduced our first product nationally, we were overwhelmed with demand. On many parts, we found that we had bought up all of the available inventory in the whole country! It is disheartening to call the largest North American distributors and find that their total nationwide stock of a critical part is fifty pieces. Since then, we have set up a relationship with a couple of smaller distributors to carry extra stock of critical components, so that even during a surge in demand we will not run out of stock. They get most of our semiconductor business.

Bob, I think that part of our frustration is that as engineers, we see the world as a bunch of tinker-toys that can be put together in various ways to achieve the results we want. Buyers can be clerical types who are used to strictly adhering to policies and rules, leaving little room for personal decision making. And senior managers are sometimes so driven to achieve quar-

# 1995 DAC DESIGNER TRACK CALL FOR PAPERS

Keep on track . . . Show the EDA world  
that you are the best!  
Submit your ideas to DAC today!

**The Design Automation Conference, the premier conference in the DA field, has broadened its scope to include the use of automation in the design of electronic systems. The user oriented sessions of the 1994 DAC attracted large audiences and were very successful.**

**We encourage submissions which will interest circuit and systems designers, design managers and DA support engineers.**

**Now is your chance to participate in the 1995 DAC!**

#### SOME SUGGESTED TOPICS ARE:

- Concurrent Engineering
- Integration of Vendor DA
- Design Reuse
- Silicon Strategies: FPGA, PLD, ASIC
- Design For Manufacture
- Top-Down Design Processes
- Standards Issues: VHDL/CFI/EDIF
- Modeling and Component Libraries
- Quality in EDA Systems
- Use of DA Tools

#### SUBMISSION TO DAC

A submission to DAC can be a regular paper or a proposal for a panel, tutorial or a special session (a group of related papers or tutorials). You should contact all of the participants mentioned in your proposal for panel, tutorial, or special session before submission.

**DEADLINE:** Submissions should be postmarked no later than **October 7, 1994**. Notice of acceptance will be mailed by February 15, 1995.

**For more information and specific requirements for submission please contact:**

Design Automation Conference  
Attn: Designer Track  
5305 Spine Rd., Ste. A • Boulder, CO 80301  
phone: (303) 530-4333 fax: (303) 530-4334  
email: DACINFO@dac.com

To encourage those who have never submitted to DAC, assistance is available for the preparation of your proposal for a panel, tutorial, paper or special session. Please contact the address above.

## 32nd Design Automation Conference®

San Francisco Moscone Center  
San Francisco, CA  
June 12 - 16, 1995



*Tools and ideas for design excellence*

sponsored by:



IEEE CIRCUITS &  
SYSTEMS SOCIETY®

EDAC  
Electronic Design Automation Companies

READER SERVICE 88

120 ELECTRONIC DESIGN  
AUGUST 22, 1994

## PEASE PORRIDGE

terly goals that they make decisions which sacrifice long-term success.

**RONALD M. JACKSON**  
*Chief Engineer*  
*Fascinating Electronics Inc.*  
*Beaverton, Ore.*

*I agree, statements that JIT saves money are SUSPECT. Seems to be a case of "proof by repeated assertion." If the world were a LINEAR place, the apples-and-oranges types would be heroes. But the world is NOT a linear place. Life ain't fair. (\*!&\*% the bean counters.)—RAP*

*Dear Mr. Pease:*

Your column in the May 30 issue, "What's All This Teledeltos Stuff, Anyhow?," was interesting. You mentioned having difficulty finding conductive paint.

A recent problem with my telephone led me to find a conductive paint pen that works very well. The flexible circuit board that is used behind the keypad developed some open circuits. The plastic obviously doesn't take to soldering without melting, so the only way to repair the traces is with a conductive paint. A few weeks before this incident, I had noticed a conductive paint pen available at Halted Specialties, 3500 Ryder St., Santa Clara, Calif. This pen makes it very easy to apply the paint just where you need it.

The pen is called the "Circuit Works" conductive pen model 2200 and costs about \$11.00. The company that manufactures the pen is Planned Products, located at 303 Potrero St., Suite 53, Santa Cruz, Calif.

**PAUL N. LEONARD**  
*Sr. Controls Engineer*  
*Matheson Electronic Products Group*  
*San Jose, Calif.*

*Exactly! That's another good way to repair conductors that don't like to be soldered—and to contact onto Teledeltos paper.—RAP*

All for now. / Comments invited!  
RAP / Robert A. Pease / Engineer

Address:  
Mail Stop D2597A  
National Semiconductor  
P.O. Box 58090  
Santa Clara, CA 95052-8090

# WHAT'S ALL THIS RENDEZVOUS STUFF, ANYHOW?

A few months ago, I proposed that a bunch of us survivors from Philbrick Researches get together for a reunion at the Hilton, across from the old Philbrick plant in Dedham, Mass. Many of the guys showed up at 5 P.M. Others straggled into the bar at 6 P.M., and others yet at 6:30. Some only arrived at 7. But we had a pretty good get-together, about three dozen people in all.

One guy, Tom, showed up around 5, went to the bar, ordered a beer, and watched everybody coming in the door. He did not recognize anybody. He got nervous, and began to wonder



**BOB PEASE**  
OBTAINED A BSEE FROM MIT IN 1961 AND IS STAFF SCIENTIST AT NATIONAL SEMICONDUCTOR CORP., SANTA CLARA, CALIF.

if he was in the right place. He called Joe, the Cruise Director, but Joe was not at home, so he left a message on Joe's phone machine. Well, Joe got the message from Tom that "I am at the Hilton—now, where the heck is everybody?" But while Tom said he was at the Hilton, he did not say any more details of where he was, exactly. At the end of the evening, we mourned the fact that our friend Tom had not arrived. Why??

Weeks later, we completed our post-mortem analysis of this situation. Tom provided proof that he had shown up at 5:01 P.M., as the receipt for his drink confirmed it. Heck, Tom could prove that he was there, and we could not

prove that we were there! The nominal time for the meeting was supposed to be 5 P.M., but I was tied up in business meetings, and arrived about 6:10. Joe, the Cruise Director, the guy in charge of coordinating the meeting, got out of work late and arrived at the meeting by about 6:40. But Tom got nervous by 6:05 P.M., and left to check out other possibilities—other locations.

Maybe we misled him, maybe we told him the wrong place to go? No, he was actually in the right place. But Tom had neglected to bring the Official Invitation (as published in *Electronic Design*, March 21, 1994, p. 116) with him.

Thus begins the comedy of errors. He could not cancel out his concerns that perhaps he was in the wrong place. And there was no real person Tom could call to ask, "OK, exactly where is the right place?"

NOW, the real culprit in this quandary is the telephone company. Apparently, most telephone companies have decided that any public phone should not have a posted number, and that you should not be able to call back to the pay phone. This is supposedly to hinder drug dealers—that's the story I heard anyway. If Tom had been able to say, "Call me back at 617-333-3333," we would have been able to tie up the loose ends easily. But the telephone company is forbidding us to use that solution. Not very helpful.

The other half of the conspiracy is that the Hilton apparently has two bars. Tom assumed correctly that we would be... in the bar. Heck, we weren't going to hire a meeting room. It would be absurd to hire a hall, when the lounge area was exactly the right place for us to meet and mingle and sip. But, apparently this Hilton had two bars. The one bar had a clear view

of the front door, so Tom could see anybody he recognized coming in the front door. But, some of us had already snuck into the other bar. That did not help much. And we, not realizing there were two bars, were remiss in checking around the lobby to see if there was another bar.

Every family has its own stories about a Rendezvous that didn't work. "We told Jimmy to wait by the Santa Claus in the store. How could *we* know that the store had *two* Santas?" It's funny *afterwards*, but not funny at the time. When we first moved to San Francisco, we volunteered to drive one of our new neighbor's kids to school. We sat and waited for the kid at the corner of Miramar and Eastwood for about 10 minutes—until we began to realize that there are *two* places where Miramar intersects Eastwood. And, sure enough, Wendell was that little *dot* down there at the *other* corner of Miramar and Eastwood.

When you go on a hike—or a canoe trip—it's surprisingly easy for one person to get separated from the rest of the group. Okay, you come out of the woods, and if the trip leader has not forewarned everybody the right place to call to reestablish connections, then you can waste lots of time trying to find each other, with each one not knowing where the other party is.

So, how do we do a Rendezvous correctly? The first thing is to have a telephone contact with a real person who can take reasonable messages and pass them along. For example, if I'm in the northeast corner of Nowhere and I suspect that my wife is searching for me in the SE corner or the SW corner of Nowhere, then we have arranged that we should each call my mother, and she can pass along the message where to go. She can take the message from the first person who calls and give it to the second person who calls. Therefore, if your mother is likely to be at home, or whoever, then agree with your wife and kids that he or she is the person you should always call. OR, if you have a cellular phone, let them call *you*. That would have helped us in Dedham, but nobody had a cellular phone. If it is a really serious situation, you could call the police and



Just one monitor,  
just two little probes,  
to measure and control  
E fields as high as 300 V/m  
from 10 kHz to 40 GHz.

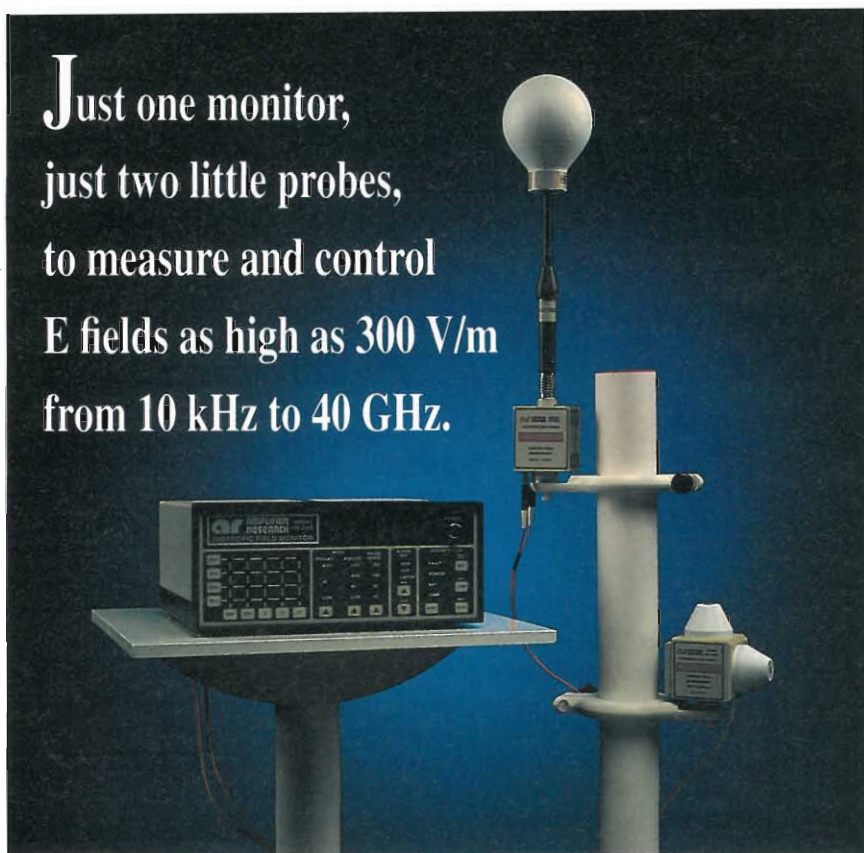

Such simplicity and breadth!

With this one compact system, you enjoy complete E-field monitoring capability up to 40 GHz, for fields from one to 300 volts per meter.

Inside your shielded room: A probe with frequency response from 10 kHz to 1 GHz (enough bandwidth for 82% of susceptibility-test applications); and another probe with a range from 80 MHz to 40 GHz. Both probes have rechargeable batteries for operation up to 40 hours.

Outside the shielded room, connected through glass fiberoptic cables that can carry signals as far as 1,000 meters, is the remarkable new FM2000 monitor — offering you total flexibility for measuring and leveling fields around the EUT.

The FM2000 accommodates up to four probes of either or both frequency ranges, for placement at various locations in the shielded room. Each probe delivers its own signals through an input card to the control

console, and you can select HI/LO/AVG readings from multiple probes at the touch of a finger on the keypad. Outputs are provided to IEEE-488 and RS-232 interfaces and 0-4 Vdc, giving you the widest choice for automatic field control — plus audible signal and SPDT contact closure for excessive-field-level or low-battery alarm.

With European and American immunity requirements increasing daily, you need a reliable ultra-broadband field-monitoring system, available from stock now, for your susceptibility testing. Get all the technical data you need on the FM2000 system. One of our applications engineers will pick up the phone himself when you call, toll-free, **1-800-933-8181**.



**ar** AMPLIFIER RESEARCH

160 School House Road  
Souderton, PA 18964-9990 USA  
Phone 215-723-8181. Fax 215-723-5688

For engineering assistance, sales, and service throughout Europe, call EMV: Munich, 089-612-8054; London, 0908-566556; Paris, 1-64-61-63-29

READER SERVICE 145

**NOW AVAILABLE!**

Four new probes for measuring magnetic fields down to 0.15 mA/m and up to 30 A/m, and very-low- (0.15 V/m) and very-high-intensity (3000 V/m) E fields.

**PEASE  
PORRIDGE**

tell them about the lost-person problem. But if the second person calls in to the *wrong policeman*, it may still take quite a while to get connected.

Do you have a phone machine, or a voice-mail system, where others can call and leave a message and then you can call in to receive your own messages? That may be a good possibility for linkup. It's one of the better ones. That's because the first logical solution—"Here's where I am, please call me back"—has been sabotaged by the telephone company, which will not let us call back to a public telephone... Anyhow, if you have any ideas on this, please let me know. *YOUR* family may have figured out some ideas better than ours.

All for now. / Comments invited!  
RAP / Robert A. Pease / Engineer

Address:  
Mail Stop D2597A  
National Semiconductor  
P.O. Box 58090  
Santa Clara, CA 95052-8090

p.s. What does *Rendezvous* really mean, anyhow? Everybody understands that it means some kind of get-together. But, how does that French phrase get translated?? Very simple: *Rendez* = present, and *Vous* = you. Thus, "Present yourself"—this represents an agreement that we will all "present ourselves" at the agreed-upon time and place. Ain't etymology interesting? I think so... what's all this etymology stuff, anyhow?

p.p.s. If you're a strong, fast hiker, you'd probably enjoy hiking across England from the west coast (from St. Bees on the Irish Sea) to Robin Hood's Bay on the North Sea. It's only 192 miles on the "Wainright route," wending through the handsome, rugged countryside of the Lake District, the Yorkshire Dales, and the North York Moors. You can take all the time in the world—or you can do it in 12 days as we did, hiking with Avalon Trekking of Perth, Scotland. From the U.S.A., call 011-44-738-624194 for a brochure. Or, ask Wilderness Travel, Berkeley, Calif., at 510-548-0420 for their brochure, as they hike about 8 to 12 miles per day.

## PEASE PORRIDGE



# BOB'S MAILBOX

### Dear Mr. Pease:

An ex-student of mine, Anthony Bentley, sent me a copy of your June 13 article on Fuzzy Logic. Tony was in charge of Feedback Control in the Welding Department at Sandia in Livermore and transferred a few months ago to Feedback Control Applications at Sandia in Albuquerque. He successfully designed automated machines for a variety of welding systems. He feels pretty much the same as you about Fuzzy Logic, and so do I.

You might be amazed at the large number of highly mathematical journals devoted entirely to Fuzzy Logic—mathematics for its own sake. My own research area is in feedback design for highly uncertain systems—linear, nonlinear, time-invariant or time-varying, single and multiple input-output—with emphasis on quantitative design. I have tried to judge F.L. by seeking a significantly uncertain system, showing a systematic F.L. design procedure for trying to achieve desired performance specifications.

For example, consider a 4-by-4 multiple-input multiple-output, highly uncertain, nonlinear, time-varying system with assigned performance tolerances. We have a systematic design procedure that can handle problems such as this. In fact, this particular one can be done in a few hours without even using a computer. Anyhow, after a few hours in the library (besides always being on the lookout for such), I was not able to find a single such F.L. example. This is the case also for “H-infinity,” a highly mathematical so-called design procedure for linear time-invariant feedback control problems.

Fuzzy Logic, H-infinity, and neural networks and expert systems provide many opportunities for paper-publishing and government grant solicitation. There is such a huge number of so-called researchers who are “driven” by the need to write papers! These are convenient vehicles for this

purpose. There is no concern for practicality. For example, the *IEEE Transactions on Automatic Control*, gave their best practical paper award, a few years ago, to a paper authored by two professors from the prestigious CalTech, plus one visiting professor from Sweden, and the design had no simulation whatsoever.

When a colleague of mine simulated their design, he found it to be instable. He notified them. They claimed a misprint, and gave him another design. He tried it and found it to be fantastically underdamped and with four infinite-bandwidth, high-gain (72 dB) compensating amplifiers. And this design theory is being extensively taught in graduate courses in the universities! Most Professors of Feedback Control in Electrical Engineering Departments in the universities (it is somewhat better in Mechanical Engineering) know extremely little about practical control systems, and really do not care—so long as they get government grants.

### ISAAC HOROWITZ

#### Boulder, Colo.

*Mr. Horowitz: On the many, many Fuzzy Logic papers filled with hype, I agree with you. But soon we will see GOOD F.L. systems; more later. Meanwhile, every serious control engineer should study Mr. Horowitz's book “Quantitative Feedback Design Theory (QFT) Vol. 1”—I've bought a copy. Request a brochure from the author at (303) 499-5357 or e-mail: horowitz@schof.colorado.edu—RAP*

### Dear Bob:

I am enclosing an article from *Design News* that covers the new Whirlpool fridge. It appears they are using Fuzzy Logic for adaptive defrost control. I find this somewhat humorous as I have been working in the HVAC controls business for 10 years and we have always used adaptive PID control in our designs. Does this mean we have been using Fuzzy Logic without even knowing it? I still think I could

make the Whirlpool defrost work better without Fuzzy Logic. I kind of agree with you—on a lot of the applications, only the logic of their reasoning is fuzzy.

On the subject of *The Audio Critic*, I must disagree with their debunking of myths. I have been a high-end audio enthusiast for a long time and to claim that all amps of similar specs sound the same is absolutely false (*The Audio Critic* has claimed this for some time). What I have discovered is that most high-end amps, particularly vacuum-tube amps, are much more sensitive to loading of the inputs and outputs than mid-fi equipment. Therefore, the length and impedance of the cables you use to interconnect the equipment can have a profound effect on the sound. But to say that you can insert several different amps into the same system using the same cables and have them all sound the same (assuming similar specs) is without foundation. Sounds good in theory, though.

The so-called “holographic” imaging capabilities of high-end components (vacuum tubes in particular) are very real and I haven't been able to duplicate the results with any mid-fi equipment. Maybe there is “magic in the tubes”. Anyway, I just thought I would throw in my own hobbyist observations for what they are worth.

I have been building my own audio equipment for 22 years and I have a BEE from Georgia Tech ('84). If you really share *The Audio Critic's* views, don't feel bad. I studied under W. Marshall Leach at Tech and he believes audio amps of similar specs sound the same, too. Maybe you just have to know what to listen for; until I heard the imaging magic of a system done right, I also was an unbeliever.

### SAMUEL E. JONES

*Systems Engineer  
Automated Logic  
Marietta, Georgia*

*I don't recall saying that “audio amps of similar specs sound the*

# PEASE PORRIDGE

same." I'm just a skeptic on all high-tech audio equipment. The only thing I'm an expert on is the splicing of speaker wires.—RAP

**Dear Mr. Pease:**

A few issues ago you wrote a comment about how "tube sound" could be implemented by including circuitry to produce second-harmonic distortion in a transistor circuit that would otherwise produce relatively clean sound.

I have been thinking about trying this, and I was hoping you might have a simple design you would like to share. Ideally, the distortion would be adjustable and would generate only even harmonics. Ok, Bob, what kind of tricks do you have up your sleeve this time.

**JAY TS**

**Director**

**Metran Technology  
Tampa, Fla.**

*Sorry, Jay, I don't know the tricks of how to start with a clean solid-state amplifier and convert it to "the vacuum-tube sound." It's not just the distortion, it's the soft damping and the clipping, too. Can any reader recommend some technical article on this?—RAP*

**Dear Bob:**

Your article in the Feb. 7 issue on quality scored a bullseye! While in the U.S. Air Force, I was subjected to Deming's philosophy. It was just plain common sense, nothing earth-shattering.

Imagine what would happen if the "No Test" mentality is extended to other industries. Publishing companies can get rid of editors because all of the writers' work would be error-free. Computer software would never give erroneous results or fail to work. Some industries are not suited for Deming's ideas.

I was wondering if you could do an article on mean time between failure (MTBF). I recently saw a new disk drive advertised to have a MTBF of 500,000 hours. That's over 50 years. I'm interested in knowing how MTBF is determined for products. I don't believe that the 500,000 hours was determined from direct testing. Keep up

the great work!

**MIKE SUTTON**

**Santa Clara, Calif.**

*You might ask the manufacturer how the MTBF was computed. Also, you can ask how the observed failure rate compared to the estimates when they ran life tests.—RAP*

All for now. / Comments invited!  
RAP / Robert A. Pease / Engineer

Address:  
Mail Stop D2597A  
National Semiconductor  
P.O. Box 58090  
Santa Clara, CA 95052-8090

## Burr-Brown 1994—

# Applications Seminar

**Learn**—Solutions to problems in noise reduction, signal conditioning, isolation, sensor interfacing, digitizing, and more—all in an informative **ALL-DAY** session.

**Presented by**—Senior Design and Applications Engineers using inputs from our industry experts...  
Jerry Graeme and Jim Naylor.

**Receive**—Seminar Notebook  
• New Product Guide • **FREE** Samples  
• Data Sheets • Engineering Pad  
• Spice & Filter Disks • EE Pocket Reference • Applications Handbook.

**Cost**—\$35.00 includes lunch and all materials.

**Locations:**

Anaheim, CA	12/06	Houston, TX	11/17	Rochester, NY	10/03
Atlanta, GA	10/13	Indianapolis, IN	11/01	San Jose, CA	12/02
Austin, TX	11/16	La Jolla, CA	12/05	Seattle, WA	12/01
Boston, MA	10/11	Long Island, NY	10/05	Tampa, FL	10/14
Chicago, IL	11/14	Minneapolis, MN	11/04	Toronto, CAN	10/21
Cleveland, OH	10/31	Montreal, CAN	10/19	Vancouver, B.C.	11/30
Greenwich, CT	10/17	Newark, NJ	10/06	Washington, D.C.	10/12
Dallas, TX	11/18	Ottawa, CAN	10/20	Woodland Hills, CA	10/12
Detroit, MI	11/03	Philadelphia, PA	10/07		
Denver, CO	11/28	Phoenix, AZ	12/09		



Sign Up Today—Call (800) 548-6132 to register—now!



Burr-Brown Corp. • P.O. Box 11400 • Tucson, AZ 85734

READER SERVICE 226  
READER SERVICE 227 OUTSIDE U.S.



# WHAT'S ALL THIS FLIP-FLOP STUFF, ANYHOW?

A few months ago, I read that a new philosophy called "The Laws of Form" could help you design a D flip-flop with a smaller number of gates.<sup>1</sup> THAT reminded me of a trip I took 20 years ago, during which I actually did design a D flip-flop myself. I was working with some guys at Amelco, in Mountain View, Calif., on the industry's first 12-bit ADC IC, and I wanted to make a small, compact D flip-flop. I tried to do a design on the west-bound plane, but my efforts were utterly useless. I looked at the Design Rules, and I could not *begin* to design a layout for a D flip-flop. I did not know how to start.



**BOB PEASE**  
OBTAINED A  
BSEE FROM MIT  
IN 1961 AND IS  
STAFF  
SCIENTIST AT  
NATIONAL  
SEMICONDUCTOR  
CORP.,  
SANTA CLARA,  
CALIF.

the privilege of studying other people's best efforts, and if we can improve on them, we're considered wise. In this case, my cell was smaller and narrower, so a cascade of 12 of them would be a more compact block. Also, the delay to the Q-bar output was

worse, but the delay to the Q output was smaller, so the ripple counter would have less delay during a ripple carry such as from (0111 1111 1111) to (1000 0000 0000).

The next day, when the Amelco guys looked at my best layout, they figured out a way to improve my layout by another 3% decrease in cell area. I then looked at their latest effort, and conceded that I could make no more improvement.

We built the circuit, and it worked the first time. We got it into production in 1975, and we sold some. (Note, all previous converters of this much resolution were designed to be digital voltmeters, putting out their drive to LED segments. This was the first one designed to interface with 12 lines to do a straight 12-bit binary output, coded as an ADC.)

I haven't done much design on flip-flops since that time, but the world doesn't need me to design flip-flops. I heard somewhere that there are 10,000 different designs for a 2-input NOR gate, each one *slightly* different. With that many gates, who needs me?

When I found out that you could use "The Laws of Form" to make a "better" flip-flop, I got curious. Could you *really* do better than the best efforts of designers over the last 30 years? Oh, yes, "The Laws of Form" showed how you could make a T flip-flop (divide-by-2 circuit) with only six gates, instead of the usual nine. WELL, that sounded like a little progress. BUT, since the guy who drew this to my attention made some "fuzzy" comments, I was prepared to be skeptical. Skeptical? Who, me?

I studied the proposed design for the "new, improved" flip-flop. Yes,

there were only six gates—but each gate was a 3-input gate. Now, a CMOS inverter needs only two transistors, and can respond fairly fast. But a CMOS 3-input gate requires you to use six transistors, so it's definitely not as fast. In fact, a flip-flop that needs six 3-input gates will be much *larger* and *slower* than a conventional one that needs nine 2-transistor gates.

NOW, I'm in favor of trying out new concepts. If a novel approach really gives better results overall, hey, that's great. But if a new scheme merely has fewer gates, but more transistors, more area, and slower response, I can't get very enthusiastic. Further, as a friend pointed out, that 6-gate flip-flop isn't really new, since TI published that circuit more than 10 years ago. And it has few gates, which makes it hard to test....

If you want to build a flip-flop using just six transistors, as one engineer claims to have done, well, yes, you can do that, but it won't have the low-power advantages of CMOS. That sounds like RTL (resistor-transistor logic) to me, and hardly anybody uses RTL these days. The resistors get too bulky. It's transistors that are cheap, and resistors that are bulky and expensive.

George Spencer-Brown, the developer of the Laws of Form, is quoted as saying that when he began working as an engineer, he "realized the tools with which engineers worked were totally inadequate."

Spencer-Brown continues, "I gave a talk recently to engineers at Bell Labs ... but ... some time after my talk, they came to me and showed me a circuit they had designed using my principles, but it had three times the number of transistors that it needed. It seems I am the only engineer who can do it properly."<sup>2</sup> Yeah, everybody's out of step with Johnny.

The Laws of Form claim to introduce "imaginary logical values" for circuits with feedback. "Armed with these imaginary values, digital engineers can now analyze circuits with equations, rather than antiquated state diagrams."<sup>3</sup> Sounds like jolly fun for somebody else—for academics who have to publish and never have to

## PEASE PORRIDGE

make things that work. For example, the standard definition of  $m$  to the  $n$  power is  $m$  times itself  $n$  times. "This is not only wrong, but it makes us think that taking something to the zeroth power is some kind of mystery," says Spencer-Brown.<sup>4</sup> Well, what's wrong for you may be right for me. I sure hope so.

I sent away for the book, *The Laws of Form*,<sup>5</sup> just to satisfy my curiosity. Maybe it could help me design a better op amp. But when I got it, I found that it has nothing directly related to electronics, or ICs. It shows the philosophy of a certain type of abstract symbolic logic. The book is crammed full of statements such as:

"Distinction is perfect continence."  
"There can be no distinction without motive, and there can be no motive unless contents are seen to differ in value."  
"The form of any finite cardinal number of crosses can be taken as the form of an expression."  
*Knowledge*: Let a state distinguished by the distinction be marked with a mark  $\square$  of distinction. Let the state be known by the mark. Call the state the marked state."  
*Form*: Call the space cloven by any distinction, together with the entire content of the space, the form of the distinction. Call the form of the first distinction the form."  
*Value*: Call a state indicated by an expression the value of the expression."  
*Equivalence*: Call expressions of the same value equivalent. Let a sign  $=$  of equivalence be written between equivalent expressions. Now, by axiom 1,  $\square \square = \square$ . Call this the form of condensation...."<sup>6</sup>

If you like these, then you'll have a lot of fun. And if you want to learn how to make a better flip-flop—well, maybe this book will tell you how to do it. Good luck.

All for now. / Comments invited!  
RAP / Robert A. Pease / Engineer

Address:  
Mail Stop D2597A  
National Semiconductor  
P.O. Box 58090  
Santa Clara, CA 95052-8090

References:

1. *E.E. Times*, CMP Publications Inc., 600 Community Dr., Manhasset, NY 11030. Feb. 14, 1994, pp. 1, 31-35; Feb. 21, pp. 31-33.; March 7, pp. 43, 62; March 14, pp. 37-39.
2. *E.E. Times*, Feb. 14, p. 31, 35.
3. *Ibid.*, p. 34.
4. *E.E. Times*, March 7, p. 43.

5. *The Laws of Form*, by George Spencer Brown, Tarati Press, Published by Cognizers Connection, 4th Printing, 1994. Order from Bookmasters, (800) 247-6553 or (419) 281-1802; fax (419) 281-6883. About \$50.00, plus \$5.00 S&H
6. *Ibid.*, pp. 1-16.

## Burr-Brown 1994—

# Applications Seminar

**Learn**—Solutions to problems in noise reduction, signal conditioning, isolation, sensor interfacing, digitizing, and more—all in an informative **ALL-DAY** session.

**Presented by**—Senior Design and Applications Engineers using inputs from our industry experts...  
Jerry Graeme and Jim Naylor.

**Receive**—Seminar Notebook  
• New Product Guide • **FREE** Samples  
• Data Sheets • Engineering Pad  
• Spice & Filter Disks • EE Pocket Reference • Applications Handbook.

**Cost**—\$35.00 includes lunch and all materials.

### Locations:

Anaheim, CA	12/06	Houston, TX	11/17	Rochester, NY	10/03
Atlanta, GA	10/13	Indianapolis, IN	11/01	San Jose, CA	12/02
Austin, TX	11/16	La Jolla, CA	12/05	Seattle, WA	12/01
Boston, MA	10/11	Long Island, NY	10/05	Tampa, FL	10/14
Chicago, IL	11/14	Minneapolis, MN	11/04	Toronto, CAN	10/21
Cleveland, OH	10/31	Montreal, CAN	10/19	Vancouver, B.C.	11/30
Greenwich, CT	10/17	Newark, NJ	10/06	Washington, D.C.	10/12
Dallas, TX	11/18	Ottawa, CAN	10/20	Woodland Hills, CA	12/08
Detroit, MI	11/03	Philadelphia, PA	10/07		
Denver, CO	11/28	Phoenix, AZ	12/09		

Sign Up Today—Call (800) 548-6132 to register—now!



Burr-Brown Corp. • P.O. Box 11400 • Tucson, AZ 85734

CIRCLE 171 FOR U.S. RESPONSE

CIRCLE 178 FOR RESPONSE OUTSIDE THE U.S.

## PEASE PORRIDGE



# BOB'S MAILBOX

### Dear Bob:

I am replying to your invitation to comment on test specs. Once upon a time in a previous "incarnation," I worked at a major defense contractor on an electronic system. Most of the system was made up of modular components purchased from suppliers. As a consequence, the system performance was highly dependent upon supplier performance. Also, we used multiple vendors to reduce cost.

We specified absolute minimum parameters (easier for the incoming guys). There were some very interesting variations in the parameters from vendor to vendor. We used one vendor (Watkins-Johnson) extensively in prototype design. Their parts usually showed a normal Bell curve with the 3-sigma point at about the low spec limit. Of course there was a fair variation of actual performance with most units moderately to significantly better than spec.

When we bought other vendor's parts, the distributions were quite different. A few failed outright. A couple of amplifier vendors and one filter vendor made parts that were RIGHT at the low spec limit. Subsystems that passed easily with prototype parts failed with the new parts. The moral of the story—don't assume normal distribution from vendors until you have a track record.

Most of us can't afford Rolls Royces. Most of our customers can't either. Therefore, acceptable quality is an issue that must be managed constantly. (Tests cost money, too.)

**JAMES GRAHAM**

*Telemotive*

*Chicago, Ill.*

*When you buy components, you either have to be able to use anything that is in spec, or, you have to talk to the supplier and understand what their distributions will be like.—RAP*

### Dear Mr. Pease:

I have read your columns for many a year and have particularly enjoyed your expose of Fuzzy Logic. I write

control logic for traffic controllers and can see little or no benefit in so-called Fuzzy Logic! You are to be commended for taking on the establishment on this subject.

This letter is written, however, to congratulate you on the message conveyed in your article on JIT. I have wondered for years how any manufacturing entity could benefit by having someone else stock parts for crucial production requirements. As you point out, one way or another, someone has to pay for the inventorying of critical parts.

This reminds me of the financial gurus that claim it's *cheaper* to lease a car than to purchase. I learned long ago that most business leases are to circumvent rules or laws, or to obtain a cheap car for personal use after the company's inflated lease expires. Of course, there may be genuine reasons like poor credit or inability to borrow that would favor leasing in lieu of purchasing, but they do not make it cheaper.

Finally, I have collected articles for years about fantastic claims and inventions including leasing. You mentioned this area a few issues ago, and I agree that this is a subject that needs some airing. Perhaps I could provide some good examples for your future column.

**NEAL P. MILLIGAN**

*Gammatronix Inc.*

*Dublin, Ohio.*

*If leasing were cheaper than buying, then the guy who leases you a car would be losing money....eh?—RAP*

### Dear Mr. Pease:

I am responding to your "What's All This Apples And Oranges Stuff, Anyhow?" column. My comments are as follows. YOU HIT THE NAIL ON THE HEAD! I have experienced the arena you discussed in your "Training Course" and you get the Don Quixote award for "tilting at windmills."

My experience as a production supervisor in several small OEMs over the past 16 years has been similar, from the JIT stuff, to the ROI and Quality lectures. There are several

conclusions I have drawn that I wish to share with you.

First, I do agree with you on anticipating our customers' ordering patterns and being proactive on that front. The lack of product projections from the "executive sales force" has resulted in my finally obtaining a computer a year ago, and logging with spreadsheets and my own formulas, a manufacturing schedule.

These projections are critical to control inventory flow, manpower scheduling, etc. The executive group is empowered to drive that, yet always seem reluctant. I also believe in the GOOD, FAST, and CHEAP—pick 2, mentality. I always opt for GOOD and FAST. Cheap always causes problems in an initial prototype and pilot job, and profitability can always be improved once the roll-out begins. Product improvement is another subject that needs financial support in a manufacturing environment.

As far as purchasing goes, and only taking orders from those who order well in advance of delivery, that would be impossible unless you were the only one who could do the job. If you wish to capture the market share, you HAVE to offer better performance, quality, and customer satisfaction. Ultimately, and in conclusion, I believe that you need well-trained employees who are instilled with a caring attitude created by a strong code of ethics exhibited and driven from the top. This will result in creating the only choice for the customer.

It is indeed unfortunate that these type of lectures run rampant in the industry, and that people actually pay a lot of money to attend them. It makes you think of the saying, "those who can't, teach." Teachers are to build foundations and to free your imagination to be able to think, not confine you with a set of surrealistic rules that flow down the narrow path to nowhere. The bright spot in all this is that these people do exist and they are the few who are making the right moves. Thank you



**RA APPROVED**

**POWER THERMISTOR**

# “MARK II” Inrush Current Suppressors

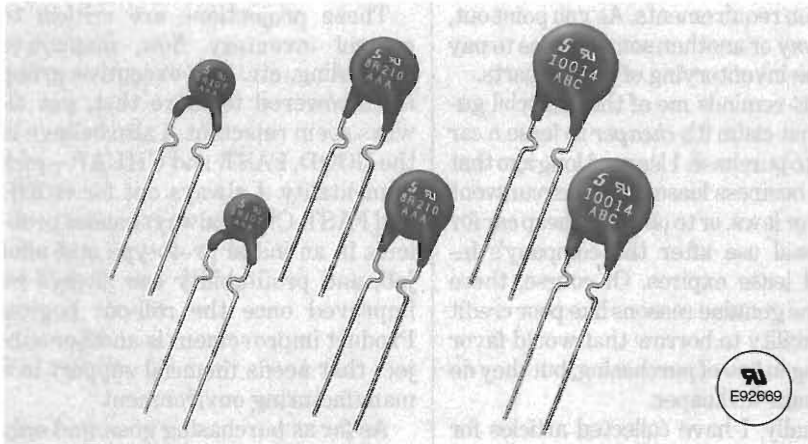

MARK II is a POWER THERMISTOR featuring smaller size and larger energy capacity to meet severe requirements in inrush current suppression.

There is the tendency of miniturization in low power switching power supply, and MARK II is effectively applicable for the needs, though the comparatively larger sized fixed resistors (ceramic coat) are used now.

ISO9002 certified company **SEMITEC**<sup>®</sup>  
**Ishizuka Electronics Corporation**

7-7, Kinshi 1-chome, Sumida-ku, Tokyo 130, Japan  
Tel: (03) 3621-2704 Fax: (03) 3623-7776

**U.S.A.: SEMITEC U.S.A. Co. Tel. 516-587-4086 Fax. 516-321-9604**

UNITED KINGDOM  
**INTEREALM LTD.** Tel: 0908 643222 Fax: 0908 372417  
**MICROTHERM LTD.** Tel: 0483 450100 Fax: 0483 451816  
FRANCE  
**BFI. IBEXSA ELECTRONIQUE** Tel: 69 33 74 00 Fax: 69 33 74 99

GERMANY  
**ACAL AURIEMA** Tel: 071 31/581-0 Fax: 071 31/581-290  
**ROEDERSTAIN** Tel: 0871/862425 Fax: 0871/82053  
ITALY  
**BFI. IBEXSA S.P.A.** Tel: 2-33100535 Fax: 2-33611603

READER SERVICE 137

**98** ELECTRONIC DESIGN  
OCTOBER 14, 1994

## PEASE PORRIDGE

for being one of them.

**BETH LEVIN**

**Production Supervisor  
Datatec Industries  
Fairfield, N.J.**

*Thanks for the sanity check. Education beats training, and we have to let our people think and ask questions, when they suspect the training is giving wrong answers.—RAP*

**Dear Bob:**

Halleluya! At last...someone is starting to talk sense about electric cars. I agree with everything you said in your Aug. 8 column, but would like to point out something that everybody who is in favor of electric cars seems to forget.

Electricity does not happen by accident. It's generated by usually fossil-fuel-burning power plants, they have been known, on occasions, to emit some polluting waste. If we would substitute all of the gas burned by millions of cars, the increased emissions from the power plants may well overwhelm us, to say nothing of the cabling to make sure every house has the ability to charge one, or two, or three car batteries overnight. Every night!

What also seems to escape discussion is the effect of the conversion efficiencies involved in the process of turning coal or oil into volts and amps. I believe, but have not calculated, that the losses in this train would more than offset any gain in efficiency by burning all the fuel in one place (the power plant), and distributing it everywhere else.

**NICK HOUSLIP**

**European Sales Manager  
Dallas Semiconductor Corp.  
Birmingham, England**

*Coal-burning power plants average 36% efficiency. An efficient car rarely beats 30% peak efficiency, and 12% average. Even after battery-charging losses, they'll beat the gasoline engine.—RAP*

All for now. / Comments invited!  
RAP / Robert A. Pease / Engineer

Address:  
Mail Stop D2597A  
National Semiconductor  
P.O. Box 58090  
Santa Clara, CA 95052-8090

# WHAT'S ALL THIS GPS STUFF, ANYHOW?

**T**he thing that just got me turned on to GPS—the Global Positioning System—was a recent advertisement I saw in an electronics magazine. “You’ll never get lost when you carry the Model X GPS global positioning system from our company.” The advertisement also showed a nice map of Trinity Lake and Weaverville, Calif., 200 miles north of San Francisco. I know this because I own an exact duplicate of the map<sup>1</sup>, a very nice map.

Yet in the advertisement, the Model X GPS receiver indicates on its LCD display that the position is 35°00′ North, and 117°52.3′ West.



**BOB PEASE**  
OBTAINED A BSEE FROM MIT IN 1961 AND IS STAFF SCIENTIST AT NATIONAL SEMICONDUCTOR CORP., SANTA CLARA, CALIF.

I’ve been interested in Global Positioning System machines for a couple years. My son Benjamin is interested in building trails in the hills around here, and I’m interested in building trails, and hiking on them, too. After he and his colleagues have built a good trail, he likes to make a

map so people can see where the trail goes. I suggested that a GPS machine might be helpful when he’s gathering the basic information for the map, rather than the old method of using compass and measuring wheel. He was skeptical, and properly so.

Recently, the prices AND sizes of Global Positioning System receivers have dropped rapidly. A machine with capabilities that would cost several thousands of dollars and fill up 8 inches of rack space just a few years ago now weighs 10 or 20 ounces and costs somewhere around \$500. The computer revolution really is applicable here. That’s because the receiver not only has to include a compact high-gain receiver at 1227.6 MHz and at 1575.42 MHz with sub-microsecond resolution in real time, it also must include a versatile computer to compute, by spherical geometry and triangulation, exactly where you are on the surface of the earth (or above it). And the elevation, too, if you give it a little extra time.

It’s pretty impressive to watch a little computer receive coded information from three or more of the 24 GPS satellites that are always whizzing by at 27,000 ft. per second at an elevation of 15,000 miles, and then compute for you exactly where you are located.

A year ago, a group of us were hiking up a trail in Yosemite Park. After a few hours, we deduced that we were about 1/4 mile east of Edson Lake, where we wanted to camp for the night. But we could not tell where it was, exactly—we could not see it, and we could not be sure if it was WSW or W or WNW of where we stood. And there was no trail to

use. So we sent out three scouts. After half an hour, all three scouts returned, and admitted they had not found the lake.

We sent out more scouts, and within an hour we found the lake. What a silly waste of time! And it’s a wonder that nobody got hurt, thrashing through the underbrush just to find where *we* were, with respect to a lake that was not lost at all. It had never been any place but right where it always had been....

So as the time for our annual backpack trip approached, I decided to buy a GPS receiver to help us with any difficult navigational tasks. I went to West Marine<sup>2</sup> and checked out the two lightest, smallest receivers. The Garmin GPS-45 was the lightest—about 9 oz.—but the Magellan Meridian seemed to have the right features, and at 14 oz., it cost \$100 less than the GPS-45 (about \$411 including tax). Now, I’m often willing to pay a reasonable premium for lighter backpacking equipment. But paying \$20 per ounce saved seemed a bit steep. So I bought the heavier but more reasonably priced Meridian. I slapped some batteries into it, and started on our backpacking trip.

First of all, let me explain a new deal to those of you who haven’t worked in this field. Of course, every USGS topographical map carries full information in degrees, minutes, and seconds. By using some interpolation with a scale or piece of folded paper, you can tell where the map says you are. Standard navigation. BUT, the user’s manual on the GPS receiver explained the new UTM (Universal Transverse Mercator) grid. All recent USGS maps show where you’re located on an arbitrary grid—a 10,000-meter grid—which is drawn on the maps.

It’s a LOT easier to interpolate on this grid, because the grid lines are only an inch or two away from any location. So I’ve done most of my computations and estimates on the UTM scale. It does seem to be quite convenient, and I’ll recommend it. But if you’re using old maps, you lose this convenience.

# PEASE PORRIDGE

Obviously, with any new system, you try to calibrate it. So, at the trail-head, I sat down at a well-defined location and turned on the receiver. After a couple minutes, the receiver said that I was at a location, which grew better-defined after another minute. But this location was up on a rocky hillside, 100 yards north of where the map said we were.

A few hours later, we sat on the north shore of Golden Trout Lake. I turned on the GPS receiver—and it said we were 100 yards away, on the south shore of the lake. About 10 times during the hike, I tried to get a correlation between the map's location and the GPS's location. Every time, the GPS had a disagreement of 100 yards north (or south) of where the map said we were (one time, it was 100 yards east).

Well, I knew that the basic military system accuracy of the GPS was very good, but for commercial uses, there were errors added by "Selective Availability," so it could not be used at full accuracy. I hadn't expected the error to have a constant magnitude and a random angle. But in retrospect, it made perfect sense. I mean, if the error was random in magnitude, one could take a large number of readings, and average them out, so as to get low errors. If the error had a constant magnitude, but a random direction, as I was seeing, it would be hard to average or cancel out the error. I also learned a few more interesting things about GPS....

One day, the "Battery Low" flag displayed on the LCD display. I decided to leave the battery pack disconnected, so I could not turn on the receiver by accident. When I turned the machine ON a couple days later, it had forgotten all of the info I had keyed into it. I thought there must be some EEPROM to save all of the info while you change your battery. Wrong.

I guess if you bought the most expensive machine in sight, you might get that kind of feature. I presume it will remember the data for a few minutes while you change batteries. It probably has a 0.1-farad capacitor

to retain power to the CMOS RAM—and the instrument's main timebase.

On the way back from our trip, I tuned in the receiver and we got rolling on the road. With 55 mph indicated on the speedometer, the GPS said we were going 53.5 mph, which was exactly the calibration error I had expected on my speedometer. The receiver is rated to be able to tell your velocity at any speed from 2.0 mph to 951 mph.

Let me also say that I'm not a sailor, so I'm slow to appreciate all of the nice navigational features that this machine can do. I DO, however, appreciate that when you're out on the ocean, and there are no landmarks, a GPS receiver would be very helpful to get you where you're going.

I ALSO appreciate that one should not rely solely on the GPS receiver for navigation—if you were counting on the GPS machine, and you ran your last battery down, and you left your sextant home, you might be in REAL TROUBLE. So Magellan Corp. was quite correct in cautioning you not to rely solely on the Global Positioning System.

After all, when we had been hiking four days, my little receiver said that we were just 7.8 miles from our trail-head, due east. But in actuality, we had to go 18 miles to get back to the trail-head, because of the wall of cliffs that stood in the way. Our maps were quite valuable in showing us that we could not reasonably or safely get up those cliffs. A straight line may be the shortest distance between two points, but it's not always the best way to get there.

Another time, we had been debating—which of those mountains over there is Mount Starr King? I thought it was THIS one, and other people insisted it was THAT one. If I had my GPS machine, I could have keyed in the location for three mountains, and the machine could have given me the compass bearing of all three. We could have proved which of the mountains was the one we were looking at. So that's a useful kind of feature.

I'm going to start petitioning my Senators and Representatives to

convince the Air Force to turn off the Selective Availability—the code that will let only military users of GPS achieve full accuracy. Since the Russians and our military people aren't targeting missiles at each other any more, it's silly to crank a purposeful error into the system, especially during peace time. Besides, the Russians are already claiming that *their* GPS system has better accuracy than *our* system, so long as we refuse to turn off the error-causing code....

While my GPS receiver isn't yet a precision machine, and while I haven't yet found it highly useful, I think it will become useful in the future—NOT a bad investment. After all, if I aim for a lake that is 200 yards long, I'm pretty sure to be able to find it with the help of a GPS machine, even if its accuracy is just  $\pm 100$  yards.

All for now. / Comments invited!  
RAP / Robert A. Pease / Engineer

Address:  
Mail Stop D2597A  
National Semiconductor  
P.O. Box 58090  
Santa Clara, CA 95052-8090

#### References:

1. *Northern California Atlas and Gazetteer*, by DeLorme Mapping Company, Freeport, Maine; phone: (207) 865-4171. This map covers all of Northern California at a scale of 2 miles per inch, with nice resolution. Also available are maps for Florida, Maine, Michigan, Minnesota, New Hampshire, New York, Ohio, Pennsylvania, Southern California, Tennessee, Vermont, Virginia, Washington, and Wisconsin. Coming soon: Illinois. The price is about \$13.00. The only minor drawback is that the elevations and contours are listed in meters ....
2. West Marine is located at 850 San Antonio Rd., Mountain View, Calif., just off Bayshore. Also at 45 other locations in the U.S. You can order by phone from 1-(800)-538-0775, or (408) 728-4430. Ask them for a catalog, which has much useful technical info. (No, you cannot buy GPS machines at Fry's.)





# BOB'S MAILBOX

**Dear Bob:**

Re: Your Electric Car Stuff column in the August 8 Issue.

From 1978 to 1986, I was involved in the "Electric Adventure," the U.S. Dept. of Energy's program to put Electric vehicles on the road and develop test data and experience in a real-world driving environment. For eight years, under contracts with the U.S. Dept. of Energy, my joint-venture partner (a new car dealer in Dallas) and I leased Electric cars to individuals and businesses in the Dallas, Texas area.

All of these cars were internal combustion engine (ICE) cars before conversion to Electric vehicles (EVs). They were, therefore, not the most optimum platforms to evaluate the limits of EV technology. They tended to be heavier than they needed to be because of all-steel construction, and extra bracing was needed to keep the U.S. Dept. of Transportation happy.

In all, we had about 20 cars on the road, including Ford Escorts, Ford full-size sedans, Pontiac compact sedans, Dodge Omnis, and even a Mercedes Benz 190. The performance of these cars was certainly adequate for any type of driving mission within the obvious limits imposed by battery capacity. Some typical characteristics of these cars is listed below:

- Top Speed—At least 70 mph (the MB 190 would do 80 mph).
- Range on Full Charge—45 to 55 miles (in the city or at highway speeds).
- Batteries Used—Lead-acid, 6-V, golf-cart batteries in a series string.
- Acceleration—Brisk up to 20 mph, about 0.1 G after that.
- Efficiency—0.3 kWh/mile dc, and 0.5-1 kWh/mile ac (from the power line).
- Battery Life—More than 10,000 miles until the range fell to 65%.
- Battery Replacement Cost—About the same as now, approximately \$1000.

**Safety Features:**

- Every car had a manual electronic disconnect "knife switch" attached to a cable and handle under the dash, similar to the hood release, but red. All were fitted with fuses as well. A traffic accident did occur, but you should have seen the other guy! The extra steel and mass of the EV kept it intact and drivable, not so with the ICE it hit.

- The batteries were housed in steel boxes with lids snapped down tight, both under the hood and in or under the trunk. Forced-air ventilation kept hydrogen at a low level. A sensor warned of ventilation failure.

- Ground-fault circuit interrupters were in each car to disconnect the 240 V ac if as much as 1 mA of ground-fault current occurred. The high-voltage battery (120 V) was not connected to the chassis of the vehicle. The 12-V system was, as usual, connected with the negative to chassis.

**Accessories:**

- Several cars had air conditioners that used about 1 kW to run when on. Since the vehicle motor used about 10 kW, the range was only reduced 10% or less—a small price to pay for comfort.

- All cars had heaters and defrosters. Some were gasoline-powered, some electric. Again, about 1 kW was required.

- All cars had power brakes, powered by a small electric motor vacuum pump.

- All had radios.
- Some had power steering, automatic transmissions (not really needed), electric windows, seat heaters (the greatest), etc.

In other words, anything you can hang onto an ICE you can hang onto an EV. The EV's motor consumes so much of the available energy, the other stuff doesn't matter much.

**Some observations:**

At first it seems different driving an EV. Then you realize one day that you've been driving around town in an

EV without giving it a second thought! I think that sums up the ease with which one adapts to EVs.

In my final report in 1985, I recommended a small ICE auxiliary power unit (APU) be installed in EVs to provide increased range and reliability. "Don't leave home without it." Eventually, fuel cells would replace the ICE APU, but the high-discharge-rate battery would still be needed for acceleration.

Batteries that have twice the energy of lead-acid have existed for at least 10 years, and they did consistently give 100-mile-plus ranges in these same cars. On a life-cycle cost basis, they are less expensive than lead-acid and would last over 100,000 miles. Edison invented them for electric cars 75 years ago—the nickel-iron battery. Some have been in use that long!

What about GM's Impact EV? They achieved a 125-mile range using lead-acid batteries. How did they do it? With a very lightweight chassis, low-rolling-friction tires (very high pressure), and a clean aerodynamic shape. Now, if you put in an Edison battery and an APU....

**GEORGE H. THIESS**

**IZU Products  
Lufkin, Texas**

*Your experiences with electric cars are quite encouraging. There's no doubt the CARS are adequate, it's just the BATTERIES that don't have enough range or life. Maybe nickel-iron will prevail. Flywheels may need more study, but I think they are "closing fast on the outside."*

*Still I don't favor 4000-lb. cars, whether ICE or EV. The real economy of EV will come at the 2000-lb. level. (If I took all the junk out of my Beetle, it might attain 2000 lbs.—RAP*

**Dear Bob:**

First, I'd like to let you know that I have been enjoying your column in each and every issue of Electronic Design. In your September 5 column on Rendezvous Stuff, you asked about

## ELECTROMAGNETIC COMPATIBILITY

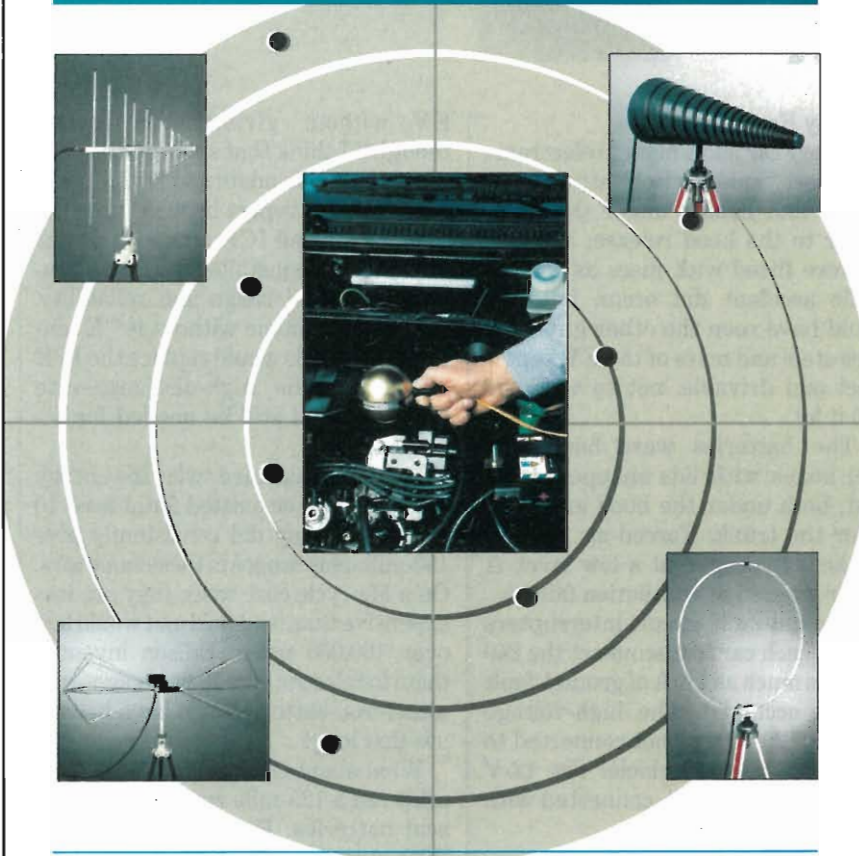

## No ECM diagnostic system scores higher !

If you need to test measure\* EMP, EMC, or very weak radiated or conducted perturbations, Thomson-CSF's Melopee System offers new standards of performance and affordability. Features include broad versatile bandwidth (1 GHz for the Melopee 1000, 1.5 GHz for the Melopee 1500), and wide dynamic measurement range in a 1 Hz analysis band (130 db for Melopee 1000, 150 db for Melopee 1500). Add high sensitivity - 1  $\mu$ Vrms/m in a 1Hz analysis band - and the ability to measure in very small volumes, and Melopee may represent your best system investment option. To learn more about Melopee system, call Thomson-CSF today. ■



\*E field, H field, voltage, current.



RADIOCOMMUNICATIONS ELECTRONIC  
WARFARE AND SECURITY DIVISION

Electromagnetic and Nuclear Departement

66, rue du Fossé Blanc - BP 156 - 92231 Gennevilliers Cedex / France - Tel. : (33-1) 46 13 34 55 - Fax : (33-1) 46 13 34 54

PEMA 2B

READER SERVICE 121

what could be done to circumvent the communication difficulty you encountered. The following is my input:

It's possible for the event coordinator to use a Telephone Answering Device (TAD) that has remote programmable OutGoing Message (OGM) capability. This feature is available on many of the newer answering-machine models, as well as most voice-mail systems. The coordinator should start with an OGM that encourages callers to leave a message if they need assistance, and to call back after a while for updated instructions.

During the initial phase of the gathering, the coordinator should check the InComing Messages (ICM) recorded on this TAD. When a "request for assistance" ICM is noted, the coordinator can change the OGM to include specific instructions in response to the need of the "lost party." When that party calls again, the OGM will be providing the updated information.

Better yet, once the coordinator has identified a communication device at the gathering site, such as the cellular phone number belonging to one of the parties already arrived, the OGM can be updated with such information. Then, all "late" or "lost" parties can easily reach the group at the gathering.

Hope the above thoughts can be of some help in the future. By the way, this technique can work for unplanned situations if the parties involved have some prior mutual understanding of this facility....

**ABRAHAM Y. CHEN**

**AC International**

**Mountain View, Calif.**

*You're quite right. I neglected to say in my column that when a group is entering a strange place (carnival, big store, city, swamp, etc.) they should always agree in advance on a good time and place to rendezvous if separated.—RAP*

All for now. / Comments invited!  
RAP / Robert A. Pease / Engineer

Address:  
Mail Stop D2597A  
National Semiconductor  
P.O. Box 58090  
Santa Clara, CA 95052-8090

# WHAT'S ALL THIS TRANSCONDUCTANCE STUFF, ANYHOW?

**R**ecently, I received this letter: *Sir: I haven't written you in a long time since you give me the "Taguchi Treatment." This is the typical "professional correctness" approach in our industry.*

*I was being laughed at for calling for reduced voltages applied to the output circuits of active devices OVER thirty years ago; today, two to three volts or less is becoming standard in computing. I was able to get a two-to-one change in output current in FETs, with 18-mV change in gate voltage, and with drain supplies of a*



**BOB PEASE**  
OBTAINED A BSEE FROM MIT IN 1961 AND IS STAFF SCIENTIST AT NATIONAL SEMICONDUCTOR CORP., SANTA CLARA, CALIF.

*few tens of millivolts applied (20 mV, for example). I knew the physics of how to do this even then.*

*The LM4250 op amp made by NSC is an excellent example of why this works ( $\pm 1.5$  V supply voltage). Unfortunately, I need some more of them. In measuring currents with bipolar devices, it is desirable that the current be measured with a voltage burden of not over about 5 mV. Which means*

*that a semi-precision op amp capable of boosting a voltage of 0.5-5 mV to 20-200 mV, with a precision 5-10%, and an offset error at the input of probably not more than 0.5 mV is needed. Where can one get such beasts (instrumentation amplifiers)? Note*

*that a burden of 200 mV measuring the current in the collector of a bipolar transistor increases device voltage gain by about 7.5, which can be enough to generate instability occasionally. Clearly, we need to be more open-minded in our profession.*

*Very truly yours, Keats A. Pullen*

I was compelled to reply: Dear Mr. Pullen, I don't criticize anybody because of political correctness, or the lack of such correctness, but because of a lack of technical correctness.

I have noticed that for many years, you have strongly criticized engineers who think that the beta of transistors is important. In your mind, that may be a matter of political correctness, or technical correctness. BUT in many technical areas it is important to have bipolar transistors with good, well-controlled beta. In other cases it's important to have well-matched beta. If you want to argue that's not true, let's talk. But, if you persist in your insulting of any engineer who talks about "beta," and who uses beta to analyze circuits, I shall rebut you with great vigor.

I will even be happy to send you some LM4250s, as free samples, but you should be cautious because the input transistors have *high* beta and are *matched*. The internal transistors have high, matched betas, too.

I was reading recently about the "good old days" of 20 years ago, when many people were building digital circuits, computers, calculators, etc., using FETs whose thresholds might shift and move several volts over their lifetime. So, 9-V power supplies were needed to make systems that would not stop working right away. You could demonstrate that a 2-V supply was enough on any given day, but the product would not keep working. Sta-

bility of operating bias isn't trivial today and it was a serious deal 20 years ago. A scientist might be called a person who can show something working once. An engineer must figure out how to make products that will last considerably longer than the warranty period.

I will certainly agree that the transconductance of transistors is very important. We usually take it for granted because it's so consistent. But you should not say, as you usually do, that we engineers don't appreciate the  $g_m$  of devices just because we don't talk about it a lot. We take it for granted.

However, I have heard your claims, over the past several years, that FETs have a transconductance so good that you can get a two-to-one change in output current for an 18-mV change in the gate voltage at room temperature. Of course, that's the same as 60 mV per decade, and is equivalent to saying that the  $g_m$ /mA is 38.6, which is a well-known theoretical maximum amount of  $g_m$  for bipolar transistors at room temperature.

Okay, Mr. Pullen, I'll call your bluff: on *EXACTLY* what FET device that you have bought, or borrowed, or fabricated, have you ever *measured* a transconductance as good as 18 mV per octave? Or, have you seen anybody else *measure* such a FET? I agree that 18 mV is a theoretical limit, never to be exceeded. No FET device ever made is that good, whether MOSFET or JFET. Not just by a few percent, but by a factor of 2 or maybe, at best, 1.5. So you won't find an octave change of drain current per 18 mV; you'll find, perhaps, at best, a factor of 27 or 36 mV per octave—not *NEARLY* as good as 18.

I asked a large number of my friends: What is the best published data, in all of the technical literature, that indicates the transconductance of any FET—MOSFET or JFET—is as good as XX mV per octave of output current? Some of them said that the  $g_m$  per mA can get extremely high, considerably *higher than*  $g_m = 38.6 \times I$ . That's if you trust your computer simulation, and if you operate the transistors at extremely low density down to the sub-threshold region, such as 0.1  $\mu$ A through a transistor 1



# PEASE PORRIDGE

micron long by 5000 microns wide.

I explained to these people that the story their computer tells them is untrue, because their computer is using an oversimplified model for FETs, with bad accuracy at starved levels. At high levels, every time you decrease the drain current by a factor of 4, the  $g_m/I$  does improve by a factor of 2—but that runs out of gas before you get to  $g_m = 38 \times I$ . The  $g_m$  doesn't ever exceed  $38 \times I$ ; in fact, it never attains  $38 \times I$ , yet does approach it. But not very closely. Other people knew that  $g_m/mA$  approaches 38.6, and doesn't exceed it—but they agreed that they didn't know how closely, nor why. Nobody recalled reading any "best published value." Several guys pointed out that they have seen 100 mV per decade on big MOSFETs operating below 0.01  $\mu A$ . That's about 30 mV per octave. Nobody had ever seen this number in the 20s.

I was helping to interview a young engineer recently, and I bounced this question off him, not expecting an answer. He simply explained that there's a virtual gate, under the gate oxide of a MOSFET. If the capacitance of this gate to ground (or, to  $V_{source}$ ) is relatively large, the capacitance of the  $C_{ox}$  would cause a capacitive voltage-divider effect, so the virtual gate never sees all of the gate voltage's change. In this case, the  $g_m/I$  will typically be reduced below 38.6 by a factor of  $C_{ox}/(C_{ox} + C_{gs})$ . This factor rarely gets better than 0.6. Even in cases where the gate oxide is very thin, as thin as 50 Å, the capacitance from the virtual gate will still be almost as big as the  $C_{ox}$ . So the  $g_m/mA$  will be poor for devices with thick gate oxide—and it can get better when the gate oxide gets thinner. However, the  $g_m/mA$  never gets very close to the maximum theoretical value. Has anybody seen better than 30 mV per octave on a MOSFET?

And JFETs (junction FETs) aren't very good, either. I measured some 2N5486s—a modern, high-performance N-channel JFET—and found the  $g_m$  as good as 25 mV per octave, but no better, not even at starved levels such as 0.1 nA. JFETs don't give high  $g_m/mA$ , because the back gate has inferior sensitivity to the front gate. If you use a tetrode FET, with the back

gate brought out separately from the front gate, the  $g_m$  is even worse.

I once saw some JFETs that had  $g_m$  about  $38 \times I$ , because they were implanted with such a light channel that they wouldn't conduct any current until they were forward-biased. Then they ran like a bipolar transistor, with injection and with finite base current, too. They were Enhancement-Mode JFETs.

Well, after this interview, the first thing I told my boss was, "We want to hire this guy who understands the  $g_m$  limitations of MOSFETs." And then I wrote down this letter.

So, Mr. Pullen, if you know where to measure any FET with a millivolts-per-octave ratio better than 25, please let us know exactly where and how we can repeat this experiment.

Yours truly, /Robert A. Pease  
p.s. Operational amplifiers with offset voltage better than 0.5 mV, such as the LM308A and many others, have been around for over 20 years. If you just connect a trim pot and optimize the offset, it's not hard to trim an op amp's offset within a few microvolts of zero. These days, offsets less than 0.025 mV or 0.010 mV, on an OP07-type amplifier, are not news—these have been around for at least 10 years. So, I don't see what your problem is. /RAP

Then I mailed the letter.

When I was a youngster in Connecticut, and knew almost nothing about electronics, I recall, VERY PLAINLY, reading in the *Hartford Courant* (about 1958), that somebody had invented a "spacistor" that would put out its current better than any existing transistor. Well, what the heck does *that* mean?

After about 15 years, I realized that these guys were probably talking about the first JFETs. All very good. And to this day, JFETs do many tasks very well. And MOSFETs, by the hundreds of billions, also do their jobs. They have small input currents. But, while their  $g_m/mA$  is *adequate*, it's not astonishing. Does anybody remember the "spacistor?" Who made it?

When I began measuring real transistors back in 1961, I was really impressed with the bipolar transistor's wide range, in which the transconductance is nicely proportional to the  $I_C$ , from 1 mA to 1 nA, or even lower. Hey,

that's pretty impressive. And I have to concede some more respect for the late Bob Widlar, for showing that a transistor's  $g_m$  can work even when the emitter voltage is *higher than* the base voltage, on an npn (bipolar) transistor. You can measure this on any germanium transistor at room temperature, or on any good npn at about 250°C. So the transconductance of a bipolar transistor is a very useful, well-known, and predictable quantity. In fact, it's only when the  $g_m$  gets *worse* than  $38.6 \times I$  that we take notice.

Ah, yes—when we work with transconductance, why do we talk about " $g_m$ ?" Well, in basic circuit theory, just as the resistance of a circuit is labeled  $r$ , the conductance of a circuit is labeled  $g$ . And when vacuum tubes came along, their gain,  $\Delta I_{out}/\Delta V_{in}$ , was in the form of a *conductance*. Furthermore, this was considered a *mutual conductance*—the voltage was applied between the grid *and the cathode*, and the output current flowed between the plate *and the cathode*. Vacuum tubes thus were characterized in terms of their *mutual conductance*, or  $g_m$ , at a given bias. When transistors came along, we kept the same term. So that's why we have the term  $g_m$ , and we still use it because it's much more compact than the phrase "transconductance."

Keats Pullen showed me an old clipping from a 1966 *IEEE Proceedings*, indicating that he had measured the  $g_m$  of some of the first experimental JFETs he ever saw, back in 1964, and he claimed they did have 38.6 millimhos per milliamper. But there wasn't any technical information on the device, no type number or model or part number—not even the manufacturer. In other words, this was not exactly a reproducible experiment.

More recently, Mr. Pullen argued that if we're just able to build FETs out of *perfectly pure silicon*, it stands to reason that the  $g_m$  will behave perfectly. Sorry, but that kind of appeal to passion falls apart when you remember that you won't have any transistor at all, unless the "perfectly pure silicon" gets doped.

Furthermore, Mr. Pullen argued that vacuum tubes also have a  $g_m$  of  $38.6 \times I$ . But this  $g_m$  is only applicable

## PEASE PORRIDGE

at 25°C, where the value of  $q/kT$  is 38.6. At higher temperatures,  $g_m$  falls. Why would a vacuum tube's  $g_m$  not correspond to the much hotter temperature of the orange-hot cathode, or the warm space-cloud of electrons swarming around it? In fact, a vacuum tube's  $g_m/I$  is rarely better than 4, which is a long way away from 38.

Then I got another letter from Mr. Pullen, pointing out that the millivolts per octave of these 1964 FETs was not 18 or 19—but 20 mV in one case, and 25 mV in the other case. All of these years, Keats has been telling us that the millivolts per octave that he had measured was 18, when actually it was 25 or 20.

I went back and measured some 2N4393s (a basic 30-Ω switch). They had 21.5 mV per octave—a considerable ways away from 18—but not much different from the ones Keats saw in 1964.

Keats Pullen has always insisted that FETs could show an octave change of  $I_D$  per 18 mV. Finally, he had to admit, when pressed, that the ones that he thought were best weren't actually as good as 18 mV per octave, but 20 mV. Well, if you mean 20, say 20, not 18.

Now, everybody I talked to said that JFETs were worse than MOSFETs, and the millivolts per octave was always worse than 25. And I was sure of that, too. And they were wrong. And I was wrong. Just goes to show... "what everybody knows" can be wrong. There's nothing like a real experiment, with real tests and real data, to puncture "what everybody knows." If any reader can tell me of any published or unpublished data, preferably from an experiment we can reproduce, showing  $g_m$  better than 20 mV per octave, on any MOSFET or JFET, at 25°C, I'd be interested to hear about it. Any theoretical analysis that explains the reasons why a JFET's millivolts per octave never gets too close to 18 would be greatly appreciated, too. Is that limitation due to doping, or geometric factors? Or something else?

All for now. / Comments invited!  
RAP / Robert A. Pease / Engineer

Address:  
Mail Stop D2597A  
National Semiconductor  
P.O. Box 58090  
Santa Clara, CA 95052-8090

## BLILEY CRYSTAL OSCILLATORS



Doubly Rotated SC Cut Crystals  
give our selected  
OCXO's better  
warmup, phase noise,  
G sensitivity  
and aging.

The Specs of our bantam style NV15A prove it:

Frequency:	5 MHz to 10 MHz
Frequency Stability:	$\pm 1 \times 10^{-8}$ 0°C to +50°C
Aging:	$5 \times 10^{-10}$ /day after 30 days
Output:	Sine Wave +13 dBm with 50 ohm load
Single Sideband	10 Hz -125 dBc/Hz
Phase Noise:	100 Hz -145 dBc/Hz 1,000 Hz -150 dBc/Hz 100 kHz -150 dBc/Hz
Power Supply:	+12Vdc $\pm 10\%$
Size:	3.030" x 1.530" x 1.530"

Call Bliley for details. We're the prime source for  
OCXO's, TCXO's, VCXO's, TCVCXO's and clocks.



BLILEY ELECTRIC COMPANY

**Bliley**

2545 West Grandview Blvd.  
P.O. Box 3428, Erie, PA 16508  
(814) 838-3571 • Fax: (814) 833-2712

READER SERVICE 153

## SCSI GIVING YOU HEADACHES?



Introductory  
Price Only  
**'99**

TAKE ONE AND CALL  
US IN THE MORNING!

Add the new **SCSI BOOSTER** to your file server or high-performance computer and solve your SCSI headaches!

**SCSI BOOSTER** cleans and regenerates the internal SCSI bus enabling optimum performance and cable distance to external peripherals.

**SCSI BOOSTER** supports "FAST", narrow, or wide SCSI for high-performance File Servers and Computer Systems.

**800-624-6808**

**APPLIED CONCEPTS**

APPLIED CONCEPTS, INC.  
9130 SW Pioneer Court, Wilsonville, OR 97070  
Phone: (503) 685-9300 • FAX: (503) 685-9099

FREE 30 Day  
Evaluation

READER SERVICE 83



# BOB'S MAILBOX

**Hey Bob:**

Thanks for the skepticism you express in your Pease Porridge column—it's what we need from editors. It's very hard to successfully compete with the deep-pocket boys from "EMPEROR'S MENS WEAR INC.," when editors glom onto every hype campaign with fawning praise.

As you have observed, the feather merchants have usurped and redefined "Corporate Reengineering" to mean fixing everything just by merely attending their seminars, being reborn, and writing checks.

Over the past 30 years, we have faced a fundamental problem in the manufacturing world which nearly defied solution. It was chaos. Chaos caused by a lack of discipline in documentation; that is to say, deplorable record keeping. Oh, the bean counters were doing fine, as always, financial accounts were fine, and they took charge of the data-processing operations and guarded them jealously.

In design and manufacturing engineering, technicians in short sleeves struggled with the production of thousands of parts and assemblies making up the product lines. They wrote many thousands of shop routings, process plans, and tool designs; and managed hundreds of machine tools and assembly operations to keep thousands of products flowing into the marketplace.

But, as we began to carefully examine the systems and procedures used by these engineers and technicians, we saw that they were overwhelmed by the sheer volume of the work and detail—plus the knowledge required to do all of this work. In fact, they couldn't even keep up with the state of the art in their own companies.

The left hand was constantly, diligently duplicating what the right hand had just done, and not too well much of the time. They were constantly reinventing the wheel. And, as the pace of change quickened, they were forced to speed up the technical work until mere confusion developed

into chaos. Duplication and unnecessary variety increased exponentially.

Product designers had little generic access to existing designs that would allow them to create better designs with each generation of change. They literally "duplicated" existing designs because they couldn't find existing parts and assemblies they could reuse in new designs. As a result, parts variety proliferated, drastically reducing production-lot sizes. The relative parts-to-workstation ratio grew out of control, and scheduling and production control became even more chaotic.

A plant that had successfully produced 30,000 different parts at previous volume "X" was strangled by complexity trying to produce 60,000 parts at half of that volume. The smaller lot sizes resulted in shorter production runs, and greatly increased downtime for setup and tool changes. Process planners blindly routed new parts through the manufacturing operations as best they could—without integrated plans or guidelines. Duplicate or similar parts were routed through whatever work center seemed appropriate to the planner, who had no ability to learn how other similar parts were routed. Or, what various routing options had yielded in cost or quality. All that information was (gasp!) lost in the files. He had no formal knowledge, or formal procedures, or formal guidelines.

Seeing this, we decided to develop tools to eliminate that chaos of knowledge unavailability. We took copies of the design and manufacturing files home with us and sorted them out. They were truly chaotic. Over 200,000 drawings in nearly random order.

Almost none of the drawing files were organized, therefore a designer could retrieve existing designs without knowing the specific part numbers of designs previously drawn. Nor could a manufacturing engineer locate similar parts or assemblies for reference. It was always cheaper and more expedient to redesign parts than to

spend hours searching through the design files for something that might not exist. Consequently, 5% to 10% of the designs on the drawing board at any given time are exact duplicates of existing designs—most "lost in the files."

Similarly, process plans are duplicated or needlessly proliferated because the existing plans for similar parts cannot be located. Thousands of parts flowing uncoordinated through the manufacturing enterprise causes pure chaos. Accountants may know how many are on order, are finished, or in inventory. But, they don't have any idea what the shop is making or how it should be made. Essentially, they don't know a great deal about what business the manufacturing organization is in!!

Manufacturing firms do not make machine tools, or appliances, or aircraft. They manufacture hundreds of thousands of parts and subassemblies that are subsequently assembled into those products. That involves an enormous task of planning and control that is nearly impossible to carry out. Parts making is the major business that the shop is in, but few managers seem to realize that.

And that parts-making process needs to be reengineered. We need to establish new tools to organize product-design knowledge. We need formalized design standards and procedures to obtain more-manufacturable designs. We need formalized process-planning systems with standard routings and rationally engineered processes.

We need to identify the specific nature of the overall production requirements before we buy another machine tool, or a new automated production system. We need to rationalize the plant layout and materials-handling system for organized, flexible manufacturing.

That's reengineering! The real Consultants have been doing it for 30 years. It's not done by generating employee empowerment in meetings of quality circles, or hotel conferences with MBA consultants. They haven't





## This Is A Happy Retirement

It's the peace of mind you get knowing you have saved for the future. It's a U.S. Savings Bond. With just a little from each paycheck, you can invest in Bonds through the Payroll Savings Plan where you work. And they will keep earning interest for up to 30 years. Make an investment in your future with U.S. Savings Bonds today. Ask your employer for details.

# U.S. Savings Bonds

A public service of this publication.



## PEASE PORRIDGE

a clue as to the nature of the problem—let alone a solution. Besides, it's too much work. They get paid excessive fees to hang banners, show slides, and mouth professorial platitudes. And, they bask in the comfort of knowing that the vast majority have climbed on their bandwagon. It all reminds me that we are truly the sons and grandsons of the Hadacol generation.

There's a lot of hard work ahead for those companies that want to find out what business they are in, and address their shortcomings. There ain't no magic pills or cheap diet plans. Neither the PC programs nor the software gurus can do the work. It requires engineering—reengineering by those who understand the problem and are able and willing to engineer the solutions. Men like them are scarce. But, look around, you just might get lucky.

**GILES E. LOVELACE CMfgE**  
**Productivity Consultant**  
**Industrial Cybernetics**  
**Charleston, S.C.**

p.s. I usually don't mail these letters, Bob. But it seems to me that industry is being sold the sizzle to the detriment of the entire society and a lot of people are joining the medicine show.

*Giles—here's your problem: It's not easy to provide a good technical DESCRIPTION of your subassemblies. We IC guys have libraries of cells: a minimum NAND, a 2X Inverter, or a 100X Buffer are easy to describe and catalog. But how do you categorize a Library of Brackets, so you can find one with 10-mm holes when you need it? And when is a bracket not a bracket? When it's a flange, or a brace, or a corbel. Man, you're gonna need a good librarian! Now, there's nothing I could possibly say about "redesign" or reengineering. But if I just happened to get some letters, I might be able (in strict confidence) to put together some interesting stories...—RAP*

All for now. / Comments invited!  
RAP / Robert A. Pease / Engineer

Address:  
Mail Stop D2597A  
National Semiconductor  
P.O. Box 58090  
Santa Clara, CA 95052-8090

# WHAT'S ALL THIS REFRIGERATOR STUFF, ANYHOW?

I plan to write about four refrigerators and an icebox; let's see what happens.... About a year ago, the radio said that Whirlpool had won the \$30 million contest for an Efficient Refrigerator. "They used Fuzzy Logic to improve the compressor, and the efficiency was improved by a factor of 3." Wow! How did they do that? A few months later, I read in *Machine Design* that Whirlpool's machine was 29% more efficient than the 1993 Federal standards. Well, that's not 3:1, but it's still quite an improvement.

I later read in *Popular Science* that



**BOB PEASE**  
OBTAINED A BSEE FROM MIT IN 1961 AND IS STAFF SCIENTIST AT NATIONAL SEMICONDUCTOR CORP., SANTA CLARA, CALIF.

the basic old refrigerator design was *already* 20% better than the Federal specs, so they only had to make an additional 9% improvement to win the contest. Well, an improvement from -20% to -29% is a relative improvement of about 11%. And about 1/3 of this was attributed to the Fuzzy Logic, which was *not* used to improve the compressor, but only to set the best time for the defrost cycle.

Then Mr. R. Shattuck of Gillette, Pa., suggested that you can connect the wiring for the defrost timer over to the *switched* side of the thermostat. This is an old refrigeration engineer's trick, so the defrost timer only runs when the compressor is running. If it's

a cold day and nobody opens the refrigerator's door, then the time between defrost cycles is extended. If it's hot and the kids are opening the door a lot, the compressor will run a lot, and the time between defrost cycles will decrease. This may provide as much gain in efficiency as is claimed by Fuzzy Logic. The alleged advantages of FL are kind of Fuzzy when you compare it to this old trick.

Now, I was still looking for a case that had a really serious debate be-

I have put on over 10<sup>6</sup> miles in VW Buses and Beetles, and I know darn well: "If the temperature in the chamber is very cold, you turn on the heat very high."

tween a good FL system and a good "conventional" system. A friend sent me a data sheet on a Fuzzy-Logic-based oven controller made by Space Industries in Texas. It claimed to provide a 10X advantage—0.3°C accuracy vs. 3°C for the "conventional" oven controller.

But I saw some data showing that this controller didn't just approach the set point and then slow down and stop. It kept cooling long after the oven temperature fell *below* the set point, and it kept the heater turned on long after the temperature rose *above*

the set point. Why didn't this controller recognize that it was approaching the set point, then slow down, turn off the heat, and settle promptly? An engineer at this company said that if the mass of the oven was nominal, the overshoot was negligible. But I observed that the data sheet for this oven said that it was rated at full accuracy with large or small thermal mass. This controller appeared to ring and oscillate for *hours* at any light amount of mass.

I volunteered to help redesign this oven controller, because I know how to make a good controller for a simple case like this. I volunteered to do this with an analog controller (a quad op amp), or a digital controller, or a Fuzzy controller. The company responded that since the controller met specs, they had no interest in further improvements. I knew I could make some serious improvements, because the Fuzzy controller responded only to the temperature error and that error's rate of change. Thus, it was like a *P-D* controller—Proportional and Derivative terms. I knew how to make a *PID* controller, which added an *Integral* term. By adding an integrating term to increase the gain for long-term errors, I could cut back on the Proportional Gain and improve the damping a lot. (If you don't have any Integral Term, it forces you to turn up the proportional gain to get good accuracy, which causes the ringing.) In fact, I bet I could meet 0.03°C....

Well, the engineer at this company decided he didn't want to be helped. That reminds me of the old lady who had to be helped across the street by five Boy Scouts because she did not *want* to cross the street.

I studied this some more. Some people—even guys at USC—claim that there's an inordinate number of Fuzzy Rules you have to write in Fuzzy Logic if you advance from 2 dimensions to 3 or 4 variables. If you want to write 7 rules for each dimension, then you'd have to increase the number of rules you write from 49 to 343 to 2401. Wow, that's a heavy load. I mean, the Fuzzy Logic enthusiasts always say it's fun and easy to write the rules for Fuzzy Logic. Oh, yeah, but it gets tedious when you

# PEASE PORRIDGE

have to write 300 rules, and when you have to write 2400, that really gets to be hard work. So most Fuzzy engineers decide that they don't have to use 3 variables—they can get perfectly fine results with 2 variables (they may be wrong....).

Well, there's no real reason that you

have to write 7 rules in any one dimension, for any one parameter. So, maybe you can write  $3 \times 2 \times 3$  rules, rather than  $7 \times 7 \times 7$ . Now, you might not be able to do this if the system is heavily nonlinear. You might have to write  $7 \times 3 \times 2$  rules, which still isn't more than 49. SO, a person could write

the rules for a fairly linear PID FL controller and still not run out of ink. (Note, you might want to avoid getting into a hissing contest with a guy who buys his ink by the barrel.) So, the "explosion of rules" may turn out to be no big deal. And a Fuzzy PID controller can be easy and effective to accomplish—and can perform lots of tasks much better than a simple PD type.

One of the rules I saw for a heater written in Fuzzy Logic went: "If the temperature in the chamber is very cold, turn on the heat very high." My comment on this is: How many of you guys ever owned a VW, Beetle or Bus? I have put on over  $10^6$  miles in VW Buses and Beetles, and I know darn well: "If the temperature in the chamber is very cold, you turn on the heat very high." Of course, you can turn up the heat in one of these old VWs all the way, and even at full throttle, the heater doesn't kick out enough heat to keep you warm when it's below zero outside. Is that a refrigerator? Or is it just an icebox?

It's not the fault of the controller, it's the fault of the heater's capacity. BUT, even if the heater does have enough heating capacity at  $+40^\circ\text{F}$  outside, you could only get the heat to turn on to full heat when the inside temperature had already gotten too cold, if you used that Fuzzy rule.

Then you could never get the controller to give good results. The weakness there is, if you trust the conventional way that rules are written for FL, most engineers don't understand the limitations of PD controllers, and they don't understand the advantages of PID, but they think they can beat the game. They might be wrong. (I don't mind the weak heater in my '68 Beetle, because I make sure to bring along plenty of warm clothes for cold-weather travel.)

Recently, we got a letter from an engineer asking, if he buys a "Greenplug," can he use this NASA-based technology to save on energy running his refrigerator? I got several letters from readers. One of them pointed out that the "Greenplug" does NOT use the old NASA technology, but is just a switch-mode voltage regulator. If the line voltage at your house is typically 124 V, you might save some en-

## 4-20mA Transmitter with High-Current Bridge Driver XTR501

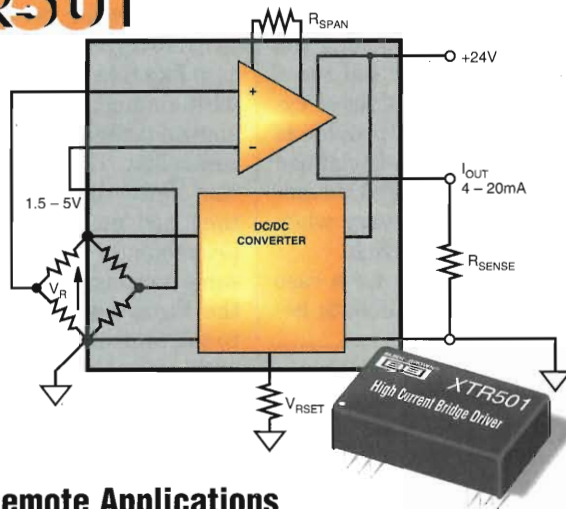

### Ideal for Remote Applications

**XTR501** is a 4-20mA transmitter with high bridge excitation current. It is a high efficiency, programmable 1W bridge supply and programmable 4-20mA current transmitter in a compact package. Designed to accommodate line loop resistance up to  $100\Omega$ , its inrush current limiting also makes XTR501 ideal for remote operation applications.

### Saves Space, Time, and Cable Costs

**XTR501** is very easy to use—one resistor sets the current output span and another resistor sets the bridge voltage. Its compact size beats discrete designs; and, it allows designers to save on cabling costs. If you're designing sensors requiring up to 600mA of excitation current, XTR501 is perfect for your gas sensors, flow meters (hot-wire anemometers), weigh scales, strain gage, and high current bridge applications.

### XTR501 Key Specifications

- Variable sensor excitation .....1.5V to 5.0V at 1W
- Supply range .....11.4 to 30VDC
- Size .....2.5" x 1.3" x 0.7"

Need a data sheet or more information? Just FAX (800) 741-3895. Or, contact your local sales representative.



Austria (43) 1 602 63 71, France (33) 1 395 43558, Germany (49) 711 77040, Italy (39) 2 580 10504,  
Japan (81) 33 586 8141, Netherlands (31) 3465 50204, Switzerland (41) 1 7240928, United Kingdom (44) 923 233837.

CIRCLE 133 FOR U.S. RESPONSE

CIRCLE 134 FOR RESPONSE OUTSIDE THE U.S.



## PEASE PORRIDGE

ergy. But if your line is at 106 V, you may not save anything.

Another guy sent in the results of Consumer Reports' testing which revealed that on old refrigerators you could save a *few* percent, but on a newer refrigerator, you might not save any electricity at all—or, you might get *less* efficiency than without. Then someone else said his Greenplug had failed, and he found out only after several days when the contents of his warm freezer let him know. (Send me a SASE for the schematic of an updated low-power detector/alarm for freezer failure.)

Other people sent in glowing claims for other "economizer" controllers that would save energy "by not letting the refrigerator's motor get too much voltage or too much current." BUT then I began to see a scary problem: If a refrigerator is running, and power is lost for a few seconds and then restored, the compressor can usually start, even against the back pressure. But if the line voltage is low, and the line's impedance is soft, the compressor may stall. It might even blow a fuse, or blow out the "economizer." And this is all compounded by the fact that the "economizer" is *trying* to provide a soft startup voltage and a small startup current.

If you want to buy an "economizer" for *your* refrigerator, make sure that the "economizer" is approved by the manufacturer of your refrigerator. They would be best qualified to certify that restart under low-line conditions won't cause stalls or damage.

Finally, I must say that I smile every time I hear about our Secretary of Defense, William Perry. Imagine that—a 340-lb. "refrigerator" in the Pentagon! (Even those of you who aren't football fans may know, with some prompting, about William "the Refrigerator" Perry who plays for Philadelphia....) But, maybe that was a different guy? Enough!

All for now. / Comments invited!  
RAP / Robert A. Pease / Engineer

Address:  
Mail Stop D2597A  
National Semiconductor  
P.O. Box 58090  
Santa Clara, CA 95052-8090

CheckMate helped NorthStar  
navigate their code.

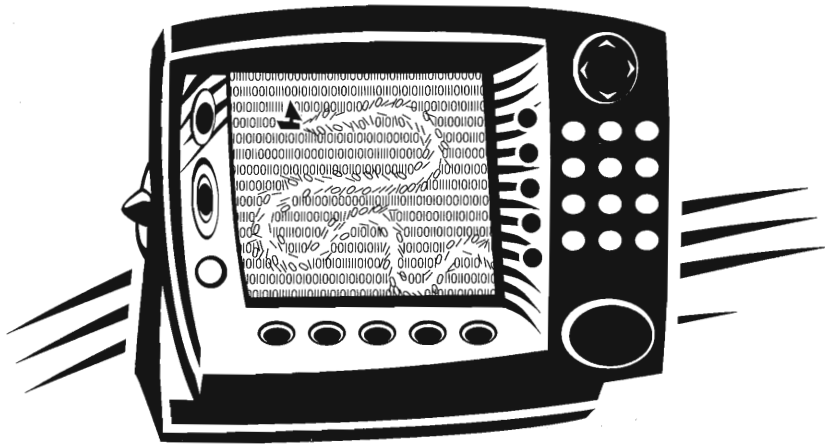

When NorthStar was adrift in a sea of code, they called on CheckMate to help show them the way. Guaranteed to run in target, at 1/3 the cost of traditional box emulators, CheckMate helps more x86 designs than any other. Make your next design faster and easier. Call CheckMate at 1-206-869-7211.



**CheckMate Systems** Emulation for the masses.

P.O. Box 3361, Redmond, Washington 98073-3361, FAX 206-861-3647

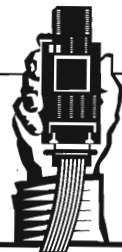

READER SERVICE 182

It's a lightweight,  
mesh-like, single-unit structure

It wraps, laminates, contracts and expands

It conducts heat and electricity

It shields EMI, RFI and ESD

**MicroGrid<sup>®</sup>** Precision-Expanded Metal Foil

Highly engineered characteristics. Up to 95% open area. In most metals.  
Call for a free sample.

**DELKER**  
CORPORATION

16 Commercial St., PO Box 427, Branford, CT 06405 203/481-4277 FAX: 203/488-6902

READER SERVICE 124

# WHAT'S ALL THIS DESIGNER STUFF, ANYHOW?

A little while ago, I ran across an article in *Trains* magazine (Oct. 1994, pp. 46-49) about "Martin Blomberg, designer extraordinaire." What did Mr. Blomberg design—a snazzy engine paint job? A new kind of Diesel engine? Nope. He designed the "Blomberg truck." It's an improved frame that goes under each end of an engine—a wheel assembly with two axles, four wheels, and two big 300-kW electric motors. This truck was designed by Mr. Blomberg for the Electro-Motive Corp., a subsidiary of General Motors Corp., in 1937. This was first used



**BOB PEASE**  
OBTAINED A  
BSEE FROM MIT  
IN 1961 AND IS  
STAFF  
SCIENTIST AT  
NATIONAL  
SEMICONDUCT-  
OR CORP.,  
SANTA CLARA,  
CALIF.

on a Demonstrator freight locomotive, which logged 83,000 miles on 20 railroads in 1939-1940, and was acclaimed as a great success wherever it went. Blomberg's truck is still in use today on most of the GMC freight locomotives. I think that's pretty good for a piece of 1939 engineering.

Why was the Blomberg truck considered such a good design? Well, previously, diesel passenger engines ran on flexible six-wheel trucks with two traction motors. The middle axle carried weight, but was not available to be powered. The early Diesel-electric engines had rigid four-wheel trucks and were suitable for yard switchers, not for long-distance, high-speed freight hauling.

They had as good stability and ride comfort as steam freight engines, but not much better. In the late 1930s, Diesel engineers had to plan new freight engines that could move freight at fairly high speeds—but put out more power and more tractive force than any passenger locomotive. In other words, they had to provide the advantages of all the old, slow diesel switcher engines—and the advantages of the sleek fast passenger engines—yet put out a lot more power.

**H**e could be very courteous, but his standard answer, if anyone approached his 'territorial waters' with a suggestion was, 'Ve do it my vay.'

Mr. Blomberg's new truck design did that. It put all the weight on the driving wheels without any unpowered axle. He provided a firm but flexible suspension, putting all the weight evenly on all four wheels. According to the article, "He designed the truck with a minimum of assistance, for there were no others at EMC acquainted with truck design. Strain gauges were crude, and finite element analysis was decades away. The designer himself had to rely on fairly simple calculations and a strong sense of mechanical aptitude,

with perhaps a little luck added."

So, what kind of man was Martin Blomberg? "He could be very courteous, but his standard answer, if anyone approached his 'territorial waters' with a suggestion was, 'Ve do it my vay.'" Does that sound like anybody you know?

Recently, I was trying to write down the Job Description for a Product Engineer. Just for the heck of it, I also wrote down, for comparison, a definition of a Design Engineer. There's a lot of similarity, a lot of overlap, except for one major difference: A good Design Engineer not only has to put together a lot of circuit functions, using known designs, but he also must know when existing designs aren't good enough, and when and *how* to make new circuits.

What is a "Designer"? Is he/she a person who designs circuits? Wears flamboyant clothing and plans the decor for a house or an office—or a locomotive? Designs the transmission or the grille for a new car? Well, yes, a designer can be any or all of these things. But after you learn how to analyze things and prove the feasibility of a design, it's also of great value to be able to invent new circuits—new designs. To do that, you have to be familiar with lots of old designs. You have to know what each old design did well, and what it did badly. Basically, you just have to KNOW lots of old designs.

When I started designing discrete-component op amps in 1961, I studied every circuit I could lay my hands on—voltage regulators, vacuum-tube circuits, transistorized circuits. I used good old, proven circuits when I could and invented new ideas when the old ideas weren't good enough. As I said in my first column four whole years ago, "computers may be able to help you optimize a given design, but it is not necessarily helpful when the old design is not good enough." Guys like Bob Widlar, Bob Dobkin, and many others knew how to innovate. I can't say I'm in the top echelon of innovators, but I know how to get a job done.

Note, you can learn a number of things in school, in college, but almost nobody learns a lot of circuits—or a lot



## PEASE PORRIDGE

of anything in detail. In the old days, a person had to LEARN a lot of circuits to get his amateur radio license. But these days, learning about and understanding a number of radio circuits—receivers and transmitters—is no longer required.

When I began to get interested in circuits around my senior year, when I got out of the Physics course and into EE, I got an appetite for learning a large number of circuits. I really got engrossed in this, as if it were a hobby. Only if you're REALLY interested in a field, like the most enthusiastic hobbyist, will you learn all the history of design, so you can tell when you have to break new ground and invent new circuits. Most students never get that interested—they have to take a smattering of courses on many different subjects to be able to graduate. That's not the kind of intensity you need to be a good designer.

In addition, when you're innovating, you must be good at circuit analysis so you can see problems, drawbacks, and limitations of new circuits. You must be good at this, by intuition or by quick analysis, so that you don't have to drag every new circuit through a long, slow Spice analysis. Besides, as I've mentioned many times, Spice might tell you a circuit would not work even when it really does. You can't run every potentially good idea through Spice.

Recently, I was trying to design a low-power R-S flip-flop in a bipolar circuit. I invented about four designs. Each one looked pretty good until I really did a one-minute pencil-and-paper analysis. Blah. They would not work. I finally asked a buddy for advice. He told me about a circuit he had used. We couldn't use that one due to power-supply limitations. But, I modified that circuit to go with some low-voltage comparators I already had and everything clicked. I haven't even bothered to breadboard it, nor to Spice it, because I can see how it has to work, perfectly, using just a little pencil and paper.

Now, I try to avoid saying good or bad things about a competitor, so I won't. But I will mention something about a new design made by a kid engineer at National about 20 years

ago. Once upon a time, we had an LM109, designed by Bob Widlar, and it was good for about 1.5 A at 5 V. We also had an LM140, designed by George Cleveland. It had a much smaller die size and would do 1.5 A at room temperature, but only 1 A at all temperatures.

It was designed to be competitive commercially, especially when competing with Fairchild's UA7805. Unlike the LM109, the LM140 came in several different voltages—5, 6, 8, 9, 10, 12, 15, 18, and 24 V. We knew that, obviously, customers needed various different output voltages.

About 1974, Bob Dobkin asked Brent Welling, the Manager of Marketing for Linear, "What if you could have an adjustable voltage regulator that you could adjust to any voltage from 1.2 V to 40 V?" Brent asked, "Will the die size be bigger than the LM140?" Answer, yes. "Will it cost more to manufacture than an LM140?" Answer, yes. So Brent said, "Well, then there will not be any possibility of significant sales."

I'm not exactly sure how we did it, but in those days at NSC, we didn't have "teams." We didn't exactly have consensus. We didn't always have harmony and sweetness and light. But we had ways of getting parts out. I wonder if we wouldn't be better off if we could reconstruct that....

Anyhow, Bob Dobkin convinced us to get the LM117 into production, and it was a big winner. Of course, the LM117 has never outsold the LM140 in number of chips sold, because the LM140 was quite adequate for simple requirements. But the LM117 made a good profit because it made lots of customers happy in critical applications.

Why? Well, it had a BIGGER power transistor with more ballasting. So, you could get more power out of it, at higher voltages, without blowing it up. Some of NSC's competitors tried to make an LM117, copying the LM117's good control circuit. But they used a smaller power transistor so they could get a cheaper, smaller die. As a result, their "117s" blew up with minimum abuse. So the LM117 sold well, because it could really do things that competitors could not do.

Here's another quote from *Trains*: "Blomberg's truck design has been able to withstand the far greater demands imposed by today's locomotives with their higher horsepower and increased tractive effort. It has been said that he was not as cost-conscious as he should have been, that his designs were heavier than necessary, and that he would not listen to others. Many people would gladly plead guilty to such criticisms if their designs could be as successful as Blomberg's." Ain't that what Dobkin did with his LM117?

What else should a designer do? He must not just think of how to meet specs—although that's important, too. He/she must think like a customer (a user) and see what will really make them happy—and avoid things that would make a customer unhappy. You have to put on a marketing hat to see what features will appeal to the customer. You have to close your eyes and think—"how can I write a data sheet that will have sex appeal to engineers?" And if you can think of an advertisement, so much the better!

You have to be careful not to build in features that are excessively hard or expensive to make in production. You have to plan that any necessary test can actually be done without a lot of wasted time and expense.

Obviously, in every field—in styling a car, in decorating a room or a building, in designing a nine-ton two-axle truck to carry freight engines—you have to think about all of these facets. A good designer neglects none of these. Yeah, that's a truism. But it *is* true.

Recently, some outstanding engineers were described by the publication *American Heritage of Invention & Technology* as "bold, self-reliant, independent, secure, powerful, daring, resolute, and sometimes, arrogant and overbearing." So, what's new?

All for now. / Comments invited!  
RAP / Robert A. Pease / Engineer

Address:  
Mail Stop D2597A  
National Semiconductor  
P.O. Box 58090  
Santa Clara, CA 95052-8090



## PEASE PORRIDGE



# BOB'S MAILBOX

### Dear Mr. Pease:

Your Oct. 25 column hit close to home. I was one of the original members of the design team for the Trimble SCOUT (and all the handhelds from that lineage, for that matter). Now, I don't know where the picture of the SCOUT came from, but in either case I blame the marketing people who care more about how the product looks in the ad than how accurate the ad is! I'm sure this is a rare event and never happens where you work.

As far as the rest of the article:

1) Storing that 'info' in EEPROM: EEPROM still is not that inexpensive to store all the data that GPS satellites generate. We had problems with total write-cycle numbers once, so we might still be a little gun shy, too. SRAM is cheap and easy to back up in a system that already has batteries. I'm sure that somewhere in their manual it states how long you should take to change out the batteries, and to leave them in until ready to do so. You wouldn't do that with your HP calculator, would you?

2) Have you heard about DGPS? The 'D' stands for Differential, where a GPS receiver that has been very accurately surveyed compares the GPS signal it receives to where it knows it is, and then broadcasts the correction factor over some RF channel. The Coast Guard is currently outfitting its stations with this capability with no charge to the end user. Of course, you need the appropriate receiver, and, since it is the Coast Guard, you need to be near WATER (within 100 miles or so, your mileage may vary). Some other services broadcast corrections over the FM subcarrier, but charge a monthly fee in addition to the receiver. But, DGPS can repeatedly get you to within 5 or 10 meters of a spot!! And your Meridian, as are ours, is differential-ready.

3) Yes, you *were* able to buy a GPS receiver at Fry's, but it was not a very good one, with the worst user interface of any system I've seen in a long time!!! I guess that's why you can't

buy it at Fry's anymore.

I'm glad you're using GPS for hiking in the great outdoors. It's a clever system with some amazing applications. If you ever want to take a look at a SCOUT, REI is selling them, or you can give me a call.

**TOM PADEN**  
*MTS/tinkerer*  
*Trimble Navigation*  
*Austin, Texas*

*Of course you are right. Marketing people don't care about factual details, just the image.... No, my manual doesn't give any clue how long it will store info with the batteries out. The Fry's in Sunnyvale doesn't sell GPS receivers—but the one in Palo Alto does. Yeah, after the differential GPS is working perfectly, the Air Force will probably decide to turn off the Selective Availability.—RAP*

### Dear Bob:

Regarding the GPS Selective Availability (S/A) issue mentioned in your Oct. 25 column: It boils down to the tax-paying public being denied the benefits of a government project for which there is no rational explanation. The DOD decided to intentionally degrade the accuracy of GPS for civilian use. But then the Department of Transportation spends millions more to defeat S/A by means of U.S. Coast Guard differential correction transmitters.

The "C" version of the 50-year-old loran system, which gave repeatable accuracies of  $\pm 10$  meters in "good" reception areas is being phased out in favor of a global navigation system with an intentional  $\pm 100$ -meter error! Anyone who wishes to spend some extra money for GPS differential navigation equipment can improve their accuracy to under  $\pm 1$  meter. So, what is the rationale for degrading the system accuracy to  $\pm 100$  meters, when any user can defeat S/A by spending some extra money?

The National Academy of Public Administration is inviting comments from the public on a GPS project study. Those having comments on the

intentional inaccuracy of GPS, or any other aspects of use of the system, can send their comments to: NAPA, GPS Project, 955 L'Enfant Plaza North, Suite 4000, Washington D.C. 20024 USA; (202) 651-8014; fax: (202) 484-4899. e-mail: napagps@tmn.com

**PATRICK M. SIMMONS**  
*Navigation Technology Int'l*  
*Reno, Nev.*

*Thanks for the info. I'll write in. Readers should, too.—RAP*

### Dear Bob:

In addition to my bemusement at your unconventional mail stop designation, I found your comments on the "Taguchi effect" reminiscent of an old yarn which you may remember:

At an electric motor manufacturing plant, a newly graduated and recently hired production engineer was anxious to prove the superiority of his skills to those of an old engineer on the staff. He analyzed one of the high-production motors, and came up with a significant cost savings by a change in materials and modification in fabrication methods.

On the big day, he assembled the top management, and there on the table was the shining prototype of his modified design. He had charts and tables showing that the cost advantage of machining the brass frame with less-expensive tools and in less time more than offset the higher price of the material. The cost to produce the brass motor was reduced to 70% of the cost to produce it as presently designed with an iron frame.

The plant manager turned to the old engineer and asked, "Well, George, why didn't you come up with these cost savings?"

The old engineer simply said, "Plug it in."

**MOE LAWRENCE AITEL**  
*President*  
*A-Tech Engineering*  
*Herndon, Va.*

*Lovely, Lovely! Thank you.—RAP*  
*p.s. By any chance was the young engineer using Spice?*

# WHAT'S ALL THIS DEAD-ZONE STUFF, ANYHOW?

A few months ago, I was on a large boat (smaller than a small ship) that was going out to Santa Cruz Island off the coast of southern California. Shortly after we left port, I was taking a few photographs, and I noticed that our wake showed some *zigging* and *zagging*. Several minutes later, when the *zigging* and *zagging* still was observable, I went up near the wheelhouse. I watched the steersman turn the wheel to the right as the boat was veering to the left. She held the wheel steady for a while, but after a minute, the boat began to veer to the right and



**BOB PEASE**  
OBTAINED A  
BSEE FROM MIT  
IN 1961 AND IS  
STAFF  
SCIENTIST AT  
NATIONAL  
SEMICONDUCTOR  
CORP.,  
SANTA CLARA,  
CALIF.

ahead of the game.

I was reminded of this recently when I borrowed an old car, and I found that I had to steer alternately far to the left and then far to the right when the wind blew from one side or the other. But after just a few miles, I

got the hang of it, and I realized that I really did know how to handle this—just a big dead zone. When the car began to drift off to the left, I immediately took up all of the slack and turned the wheel right. Anybody who has driven old cars knows how they can have 2, 3, 4, or maybe even 5 inches of “play” or dead zone, as measured at the rim of the steering wheel. So I knew how to drive this old car with good accuracy.

As I considered this, I thought back to the boat. If you wanted to steer that boat in a straight line, it would be easy. It was a fairly big boat with two engines, so it would be easy to throttle back the left engine a trifle, thus setting the boat to veer to the left. Then if you cocked the rudder to the right, you would keep the rudder working against the offset of power, and the slack would be taken up consistently.

Oh heck, this reminds me of a story in the old *Lightning Empiricist*, published by George Philbrick Researches about 30 years ago. Henry Paynter, one of the most authoritative experts on Analog Computers at MIT, wrote a little story to go into that journal. His point was that hysteresis was the natural antagonist of noise or oscillation in a slow servo loop. For example, if you drove such a car, you could turn the steering wheel back and forth at a relatively high frequency. As it bumped against the active regions, alternately left and right, it would impart the desired force to turn the steering wheel in the correct direction when the need existed. So a constant amplitude oscillation could be used to virtually CANCEL OUT a dead zone of similar size.

NOW, this is exactly the converse of a case where you have a signal with

some noise or oscillation superimposed. To avoid severe noise on the output of your controller-amplifier, you can add in some hysteresis (an alternate name for a dead zone), which cancels out the oscillation. Only when the signal-plus-noise exceeds the hysteresis or dead band does a significant error signal go out to correct the loop.

If you have a loop with a dead band or dead zone, can you control this with a linear servo loop? Not very well; in fact, it will work lousy (that's a technical term) and the precision of the servo loop will be poor. YET, if you ask the dead zone and the hysteresis to cancel each other out, the loop's controllability can be improved considerably. Hey, not bad for analysis in the 1960s, with no assist from any digital computer...

In the real world, you often find dead zones in mechanical systems. When you turn the knob of a trim pot, the electrical change doesn't begin until after some dead zone. When you turn it *back*, electrical changes don't occur until there's a further rotation in the other direction. HEY, but we read that multi-turn pots are supposed to have infinite resolution. If you turn the pot to the left and to the right with infinite *mechanical* resolution, can you get to any value you want?

Let's suppose we have a 10-k $\Omega$  pot with a 1.000-V dc supply across it. Your task is to set the pot's wiper to any voltage you're asked. Your buddy says to set it to 0.307 V, and you try. But if the pot is working badly, you get to 0.304 V, and then with a tiny increase, it lurches up to 0.309 V. You try to turn the knob back, and it lurches past 0.308 V to 0.301 V. Hey, this is one of these multi-turn pots that's supposed to have “infinite” resolution. But it's not working with “infinite resolution.”

Now, you finally got the trim pot's output to 0.307 V. Just then an ant tiptoes past the pot and it shifts to 0.305 V. So, even though bad settability is bad, poor stability is *worse*. And this is one of those 22-turn pots that claims “infinite resolution.”

Well, what if you evaluate a single-turn pot? As a matter of fact, most single-turn pots are better than most

# PEASE PORRIDGE



## Class A rf amplifiers deserve Class A directional couplers.

10 kHz to 1,000 MHz, 50 to 15,000 watts cw, to 50 kW pulse

Twenty-five years of building outstanding rf power amplifiers has also taught us a thing or two about couplers. Things that give weight to the following recommendation: To monitor the output of any power amplifier in the ranges shown above, couple it to your power meter, scope, spectrum analyzer, DVM, or other measuring instrument through one of the AR dual-directional couplers you'll find listed below.

With all our couplers, you can monitor both forward and reflected power—very important in the harsh VSWR environment of EMC susceptibility testing. And, even if you may accidentally have bought someone else's power amplifier, you can still enjoy the bandwidth, directivity, and low loss of your AR dual-directional coupler. Plus the two-year AR warranty.

Call toll-free (800-933-8181)  
and talk it over with the applications  
engineer who'll answer the phone.



	DC2500	DC3001	DC3010	DC4000	DC5000	DC6000	DC6180	DC6280
Frequency range	10kHz-220MHz	100kHz-1000MHz	10kHz-1000MHz	10kHz-100MHz	220-400MHz	400-1000MHz	80-1000MHz	80-1000MHz
Power (max. watts)	2500 cw 5000 peak	50 cw 1000 peak	50 cw 1000 peak	15,000 cw 50,000 peak	2500 cw 5000 peak	1500 cw 3000 peak	600 cw 1000 peak	1500 cw 3000 peak
Coupling factor	50 ± 1 dB	40 ± 0.6 dB	40 ± 0.6 dB	60 ± 1 dB	50 ± 1 dB	50 ± 1 dB	60 ± 1 dB	63 ± 1 dB
Directivity typical	25 dB	25 dB	25 dB	25 dB	25 dB	25 dB	25 dB	25 dB
Directivity minimum	20 dB	20 dB	20 dB	20 dB	20 dB	20 dB	20 dB	20 dB
Insertion loss, max.	0.15 dB	0.5 dB	0.6 dB	0.1 dB	0.2 dB	0.2 dB	0.15 dB	0.15 dB

9450

multi-turn pots for settability or for stability under shock and vibration. You can check this out yourself.

Now, first of all, any pot with settability better than 0.1% is pretty good. If you can set a pot to 1-mV resolution out of a 1-V full scale, that's a pretty good pot. The best ones can do this fairly consistently, but if you need to set a multi-turn pot to do much better than 0.3%, you're going to waste a lot of time. And after you have actually set the pot to the desired voltage and you rap the pot lightly with a pencil, its output is likely to move. Again, the multi-turn pot more often than not will give worse stability.

Okay, go back and re-tweak the pot and re-tap the board it's mounted on. You can probably get most pots to read any millivolt you name, but the multi-turn pots take more work, more time. A smooth guy with a single-turn pot can drop the voltage quickly anywhere he wants to. It's true that he has to set the angle of the pot to a resolution of 270°/1000, which is a very small amount of rotation—25× smaller than setting a 22-turn pot. But, yes, in practice it's easier to do.

NOW, in any system, it's usually bad practice to require a pot to be set with a resolution as small as 0.1% of span. You shouldn't try to trim over an infinite range and still demand good resolution. But at least you should be aware of the problem of decent resolution.

So, hysteresis, dead zone, settability, and stability are all related, and the problems are, in practice, all mushed together. A multi-turn pot isn't necessarily closer to "infinite" stability, notwithstanding anything you read on its data sheet. And smart people, or smart systems, can learn to take up some dead zone automatically. Back in 1964, Henry Paynter had some pretty good ideas on this subject.

All for now. / Comments invited!  
RAP / Robert A. Pease / Engineer

Address:  
Mail Stop D2597A  
National Semiconductor  
P.O. Box 58090  
Santa Clara, CA 95052-8090



160 School House Road, Souderton, PA 18964-9990 USA;  
phone 215-723-8181; fax 215-723-5688. In Europe, call EMV:  
Munich, 089-612-8054; London, 0908-566556; Paris, 1-64-61-63-29.

READER SERVICE 83



## PEASE PORRIDGE



# BOB'S MAILBOX

### Dear Bob:

The "Tube Sound" letter in the Sept. 19, 1994 issue asks about a simple way to get "tube" sound from solid-state amps. The Oct. 3, 1994 issue of *Electronic Engineering Times* has an article on tube emulators which mentions one such device from Deja Vu Audio, Berkeley Springs, Va. The article goes on to discuss other "over drive" factors. While some key factors are discussed, such as overload distortion characteristics, other tube "signatures" are omitted, such as the tube amplifier's better stability into nasty reactive loads (like electrostatic speakers), high peak to rms power ratios (due to high-voltage rails of tube circuits), and lower damping factors (due to output transformer coupling and lower negative feedback).

My specialty is speaker engineering and I find that a number of characteristics attributed to amplifiers are often the interaction between the output stage and the crossover network and/or the voice coil of the speaker. The differences between amplifiers or cables that are perceived in listening evaluations may not be directly due to the cables themselves, but caused by interactions with time-varying phenomena.

When these components are changed midway into the playback of a CD, the shift in sound characteristic may actually be the effect of the speaker voice coil heating up and the resultant impedance rise. Passive crossover network -3-dB points can shift one-half octave or more when a speaker's impedance shifts upward due to temperature coefficients. Often, a system's approach will reveal that what is being heard is an interaction between components. The differences perceived are real, but cannot simply be measured component by component. They can only be documented by looking at the whole system.

**MIKE KLASCO**  
*Menlo Scientific Ltd.*  
*Berkeley, Calif.*

*Thanks for your notes on odd thermal effects in speakers and crossover networks. Maybe we need liquid-cooled crossovers? However, those "high-voltage" rails of vacuum-tube circuits aren't really very high when properly viewed through the output transformer!—RAP*

### Dear Electronic Design Readers:

I know many of you have purchased, integrated, and operated test equipment that failed to perform in accordance with the manufacturer's specifications. Like most test engineers, I have found dozens (maybe hundreds) of problems while integrating software with "off-the-shelf" test equipment. Many of you have also spent long hours on the phone with the manufacturer trying to find workarounds—workarounds which would not have been necessary if the equipment complied with the published specifications. Perhaps you have spent several hours tracking down and classifying a problem only to find the manufacturer has a deaf ear. Do you need an alternative? Are you ready to try something new?

I am compiling a test-equipment problem database. If you will send me written descriptions of your test-equipment problems, I will attempt to categorize these problem reports. The data will be used to encourage test-equipment manufacturers to address these problems.

We should all take time to inform vendors when we have a problem and we should also take the time to warn fellow test-equipment users when vendors are unresponsive to our complaints. Please take the time to do something positive for yourself and your fellow equipment users.

I want to make this easy and flexible. You can send your complaint(s) to a mail address, a CompuServe address, or an Internet address. Since I could be swamped with complaints, I can not promise individual replies, but I will try to let the user community

know the results of the study. Please supply the following information when responding:

- Manufacturer's name
- Model number of test equipment
- Description of problem
- Approximate date of problem
- Results of contact with vendor
- Problem significance (will you still buy from this vendor?)

Complainer's name (will not be released to test-instrument vendor without consent)

Complainer's address (will not be released to test-instrument vendor without consent)

**DAVID M. ANDERSON**  
*Anderprise*  
*7227 E. Chadowes*  
*Wichita, Kans. 67206*  
*CompuServe: 74722,2622*

### Internet:

*davidm.anderson@twsubbs.twsu.edu*  
*This seems like a good idea for constructive criticism, rather than just griping. I recommend that everybody do this.—RAP*

### Dear Bob:

First, let me say how much I enjoy your column. I have your book, too, and love it. I like the way your mind works! You see right through to the essence of the true nature of things, whether in semiconductor circuits, mechanical devices, or whatever. And we both know that a little humor serves as an essential lubricant in life.

In a previous column you mentioned Tom Milligan, who was then at Philbrick, telling his people that when funny results were obtained when a circuit was under development, they should Record the Amount of Funny. This sounds like it just might be my good friend Tom Milligan, whom I once worked with in broadcasting eons ago in Charlotte, North Carolina. He then went to MIT, and I went to work for the government, and we lost track of each other. If you have his address, I would love to have it, so I can contact him.

# PEASE PORRIDGE

**JIM DAVIS**

*Springfield, Va.*

*No, we have been looking for Tom for several years. Does anybody know his whereabouts?—RAP*

**Dear Bob:**

After my return from a long trip, I can today respond to TWO of your historical (and yet enjoyable) refreshers:

1. Teledeltos paper was indeed limited to two-dimensional analysis, but I believe I once used a semilog resistance paper. To obtain 3D solutions for TWT focusing fields, I used an electrolytic tank when I worked (loosely speaking) at the Air Force Lab in Dayton, Ohio. Its probe even automatically followed equipotential lines, and the electrolyte was quite harmless—a bucket of sea water will do fine.

2. I built a V-F converter in the early 1950s, but never knew it. My lab at the Technical University of Vienna (the real one) got a grant for building a device to measure core iron losses. Those on the market needed several pounds of test samples, while I did it with as many grams. Essentially, I had to integrate the product of current and voltage over one full ac period—a hysteresis microwattmeter.

The V-F solution came to me while listening to a then young pianist named Gulda playing Beethoven (I believe it was the Hammerklavier sonata). Make constant-width pulses, I said, whose amplitude varies with the voltage, while the frequency followed the current (converted to a voltage in a grid resistor). The gadget worked well enough to get the lab its grant, and me not only a doctorate, but a patent in 1953.

Just before I left for the above-mentioned Dayton lab, Siemens wanted to prove I infringed on their electroMECHANICAL wattmeter! I convinced them to buy my patent for about \$500, which was an extra month's income on my new job. (Those were the days when a buck still got some respect.)

**MAX J. SCHINDLER**

*Boonton, N.J.*

*That's interesting to hear about your old V-F integrators! And thanks for the comments on Teledeltos paper. I got a lot of comments on 2D and 3D analogs!—RAP*

**Get the edge...  
...with Distribution Support**

## AUSTRIA

**Avnet E2000 GmbH**  
Tel. 0043 1 9112847  
Fax. 0043 1 9113853

**EBV Elektronik**  
Tel. 0043 1 8941774  
Fax. 0043 1 8941775

**Eurodis Electronics GmbH**  
Tel. 0043 1 610630  
Fax. 0043 1 61062151

**Farnell ECD GmbH**  
Tel. 0043 1 6945170  
Fax. 0043 1 694510

**Spoerle Electronic**  
Tel. 0043 1 31872700  
Fax. 0043 1 3692273

## BELGIUM

**Alcom Electronics NV/SA**  
Tel. 0032 3 4583033  
Fax. 0032 3 4583126

**EBV Elektronik**  
Tel. 0032 2 7209936  
Fax. 0032 2 7208152

**Farnell Electronic Services**  
Tel. 0032 2 7253533  
Fax. 0032 2 7254135

**Diode Spoerle**  
Tel. 0032 2 7254660  
Fax. 0032 2 7254511

## DENMARK

**Topcomp Electronics**  
Tel. 0045 33 88 39 50  
Fax. 0045 33 88 39 55

## FRANCE

**Arrow Electronique**  
Tel. 0033 1 49784978  
Fax. 0033 1 49780596

**Avnet**  
Tel. 0033 1 49652500  
Fax. 0033 1 49652769

**Farnell**  
Tel. 0033 1 64460200  
Fax. 0033 1 64463898

**Tekelec Airtron**  
Tel. 0033 1 46232425  
Fax. 0033 1 45072191

## FINLAND

**Topcomp Electronics**  
Tel. 00358 0299 4001  
Fax. 00358 0299 4188

## GERMANY

**Avnet E2000 GmbH**  
Tel. 0049 89 4511001  
Fax. 0049 89 45110129

**EBV Elektronik Vertriebs GmbH**  
Tel. 0049 89 456100  
Fax. 0049 89 464488

**Farnell Electronic Services GmbH**  
Tel. 0049 7141 487300  
Fax. 0049 7141 487210

## Glyn GmbH

Tel. 0049 6126 590222  
Fax. 0049 6126 590111

**HED Heinrich Electronic**  
Tel. 0049 201 5636251  
Fax. 0049 201 5636268

**Rein Components GmbH**  
Tel. 0049 2153 7330  
Fax. 0049 2153 733575

**Spoerle Electronic**  
Tel. 0049 6103 3040  
Fax. 0049 6103 304201

## ITALY

**Avnet Adelsy**  
Tel. 0039 2 38103100  
Fax. 0039 2 38002988

**Compres S.P.A.**  
Tel. 0039 362 553991  
Fax. 0039 362 553967 988

**Fanton**  
Tel. 0039 2 48920341  
Fax. 0039 2 4597913

**Farnell**  
Tel. 0039 2 824701  
Fax. 0039 2 8242831

**Lasi Elettronica (Div. Di Silverstar)**  
Tel. 0039 2 661431  
Fax. 0039 2 66101385

## NETHERLANDS

**Alcom Electronics**  
Tel. 0031 10 4519533  
Fax. 0031 10 4586482

**Diode Spoerle**  
Tel. 0031 3402 91234  
Fax. 0031 3402 35924

**Diode Spoerle**  
Tel. 0031 40 545430  
Fax. 0031 40 535540

**EBV Elektronik**  
Tel. 0031 3465 62353  
Fax. 0031 3465 64277

**Farnell Electronic Services**  
Tel. 0031 79 613161  
Fax. 0031 79 613169

**Rein Elektronik B.V.**  
Tel. 0031 40 431775  
Fax. 0031 40 435522

## NORWAY

**Topcomp Electronics**  
Tel. 0047 66 84 18 15  
Fax. 0047 66 84 19 17

## SPAIN

**Lober S.A.**  
Tel. 0034 1 3102925  
Fax. 0034 1 3104797

**Unitronics S.A.**  
Tel. 0034 1 5425204  
Fax. 0034 1 5484228

## SWEDEN

**Topcom Electronics**  
Tel. 0046 8 757 41 75  
Fax. 0046 8 757 47 98

## SWITZERLAND

**Avnet E2000 GmbH**  
Tel. 0041 1 7221330  
Fax. 0041 1 7221340

**EBV Elektronik**  
Tel. 0041 1 7401090  
Fax. 0041 1 7415110

**EBV Elektronik**  
Tel. 0041 21 3112804  
Fax. 0041 21 3112807

**Eurodis Electronic A.G.**  
Tel. 0041 1 8433910  
Fax. 0041 1 8434111

**Fabrimes/Spoerle**  
Tel. 0041 1 8746262  
Fax. 0041 1 8746200

**Farnell A.G.**  
Tel. 0041 1 2046111  
Fax. 0041 1 2046454

## UNITED KINGDOM

**Abacac Group**  
Tel. 0044 635 33311  
Fax. 0044 635 38432

**Anzac Components Ltd**  
Tel. 0044 628 604411  
Fax. 0044 628 660662

**Avnet Access**  
Tel. 0044 462 480888  
Fax. 0044 462 488567

**Farnell Electronic Services**  
Tel. 0044 279 626777  
Fax. 0044 279 441687

**HB Electronics**  
Tel. 0044 204 25544  
Fax. 0044 204 384911

**Impulse Electronics Ltd**  
Tel. 0044 732 743227  
Fax. 0044 732 743121

## Toshiba European Headquarters:

**Toshiba Electronics Europe GmbH**  
Hansaallee 181  
D-40549 Düsseldorf  
Tel: 0049 211 52960  
Fax: 0049 211 5296400

**Toshiba Electronics Espana S.A.**  
Tel: 0034 1 660 6700  
Fax: 0034 1 660 6799

**Toshiba Electronics Italiana S.R.L.**  
Tel: 0039 39 6057234  
Fax: 0039 39 6057252

**Toshiba Electronics France S.A.R.L.**  
Tel: 0033 1 48124812  
Fax: 0033 1 48945115

**Toshiba Electronics (UK) Ltd**  
Tel: 0044 276 694600  
Fax: 0044 276 694800

**Toshiba Electronics Scandinavia AB**  
Tel: 0046 8 7040900  
Fax: 0046 8 808459

In Touch with Tomorrow  
**TOSHIBA**

READER SERVICE 140



# WHAT'S ALL THIS TURKEY STUFF, ANYHOW?

Once upon a time, back at Philbrick Researches about 20 years ago, we were asked to quote on a spec generated by Loral, a military customer located in New York City. They wanted a very fast DAC to draw vectors. They wanted a 10-bit multiplying DAC with very low phase error, very fast response to digital code changes, and low glitches. In other words, when they changed the code—such as the worst-case carry from 0111 1111 11 to 1000 0000 00—they wanted the output jump or glitch to be small and brief. That meant the output had



**BOB PEASE**  
OBTAINED A BSEE FROM MIT IN 1961 AND IS STAFF SCIENTIST AT NATIONAL SEMICONDUCTOR CORP., SANTA CLARA, CALIF.

to settle very quickly. I figured out that a double DAC could do this (Fig. 1).

One DAC (Q1, Q2) had an offset current through R<sub>1</sub>, plus a main signal path through R<sub>2</sub>, plus a linearity correction path from a Howland current pump through R<sub>3</sub>. The second DAC (Q3, Q4) just had an offset through R<sub>4</sub>. The circuit also had a current reflector, so that when V<sub>in</sub> was zero, the current through

R<sub>1</sub> would cancel out the current through R<sub>4</sub>.

When the input signal was *not* zero, the main signal path came directly through R<sub>2</sub> quite fast. But the emitter of Q1 isn't a constant voltage. If you rely on the current through R<sub>2</sub> alone,

it wouldn't be linear. So I built a dummy bit cell and a Howland current pump. And by using A1, the current through the 20-kΩ resistor from its output to its noninverting input would cause the emitter current of Q111 to be a very linear function of V<sub>in</sub>.

Then the current through R<sub>3</sub> would cause the total current fed to Q1 to be very linear. Of course, the bit-switch was repeated about nine more times at various levels of precision and current scaling.

We built up a rather large and floppy breadboard of this. I was able to fit it inside a test oven that was about 18 in. × 12 in. × 12 in. inside. However, I soon discovered that no precision tests could be done because of thermal wobble and gradients in the oven. I needed some thermal baffling. I went out to a grocery store and bought some Turkey

bags—the kind you can roast a Turkey in. These would not melt even at 125°C. So I put the circuit in the Turkey bag, and I got the tests done. Because of the Turkey-bag, we called it a Turkey-DAC. We bid on the project. We won the business.

However, in those days, we had three departments at Philbrick: Engineering, Manufacturing, and Give-It-Away. For some reason, the salesman, to make sure we got the business, quoted a really low price. But, to get this complicated circuit into the small package, it took several hybrid parts, all of which were shoehorned into a small potting shell that was about 4 in. × 2 in. × 0.5 in.

The Current Reflector, for example, was a hybrid subassembly. This wasn't simple or cheap to manufacture, and it required lots of trims. It had offset trims, gain trims, and linearity trims. We had to build up the basic circuit, check it out, and put in the first round of initial trims or coarse trims. Then we filled up the potting shell about half way and cured the epoxy. After that, we did the next round of medium trims, which was followed by a little stabilization bake for the fine trims. More testing was done, and then we topped up the shell with epoxy. Finally, once a few more room-temp tests and high-temp tests were

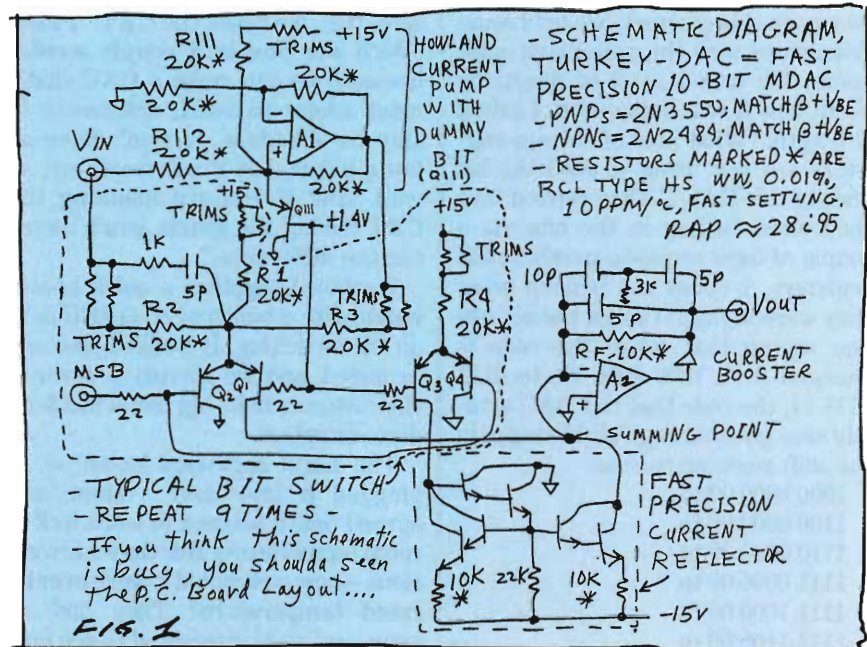



# PEASE PORRIDGE

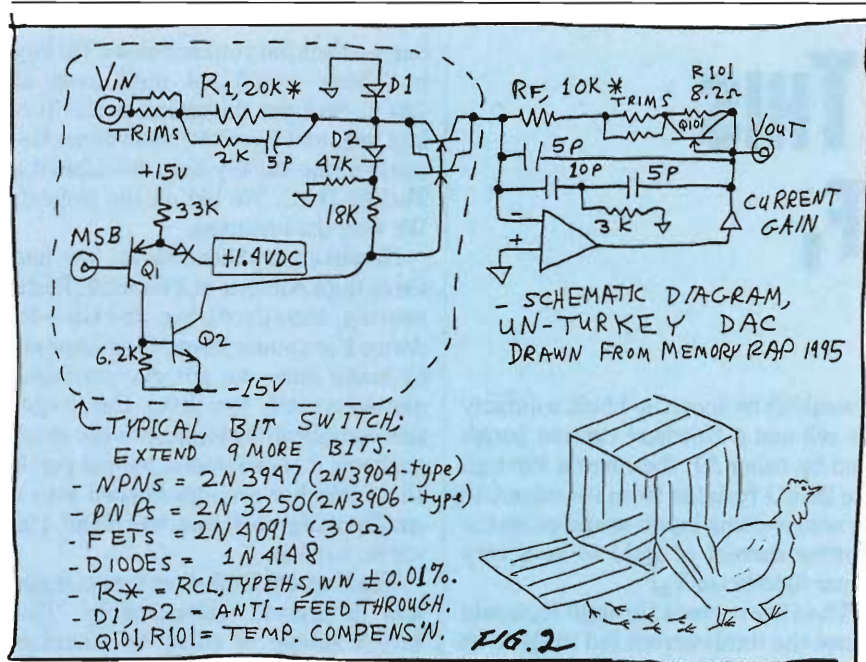

done, we could ship. We were selling this whole kluge, with all hermetic mil-spec parts, for a lousy couple hundred bucks. We were losing money on each sale, and we were NOT making it up in volume. In fact, the test and trim labor was larger than usual, and we could not get out very many DACs in a week—we were falling behind schedule on shipments despite our best efforts. This project was turning into a real Turkey. A Turkey-DAC.

Our management figured out that we had to find a way to stop losing money on this contract. We held some discussions with the customer's engineers. We asked a lot of questions about how it was being used. I asked at length, "What kind of storage registers are you using to feed the bit lines to this DAC?" They replied that they were feeding in the bits via a couple of 5495 series-to-parallel shift registers. I could not believe what they were saying!! I asked them, "Are you saying that when the code is changed from 1000 0000 00, to 0111 1111 11, the code that the DAC actually sees goes through all 10 stages in the shift register, such as:

```
1000 0000 00 to
1100 0000 00 to
1110 0000 00 to
1111 0000 00 to
1111 1000 00 to
1111 1100 00 to
```

```
1111 1110 00 to
1111 1111 00 to
1111 1111 10 to
0111 1111 11 over a period of a full
microsecond?"
```

The guy said yes. I proceeded to point out that that wasn't the right way to get a low glitch. They were paying for the low-glitch feature but not using it. They were paying a LOT for a feature that they could not see nor use. I asked them how they managed to avoid seeing a big glitch during this awful transition? They said, "Oh, we blank the CRT." I said, "We'll see you in a couple weeks, because we can make a DAC that's much easier to build, and easier to ship on schedule. It won't have as low a glitch, but it will work just as well. And if you are blanking the CRT during the glitch, you'll never see the difference."

I cobbled together a quick breadboard with a bunch of 30-Ω JFETs to do the switching. It worked just as I expected, and we carried it down to the customer in its big metal box for a demonstration.

The Loral engineers looked at it, plugged it into their system, and agreed that it seemed to work well at room temperature. But they were curious—how well would it work over its rated temperature? They had an oven, and were interested to see how

our circuit would play. We knew it would work fine, but our breadboard was much too big to fit *inside* their small oven. So we taped our breadboard to the face of their oven—in place of the oven's door. In fact, the box extended well beyond the oven. After taping it really well, they ran the tests, and the circuit worked perfectly at all temperatures. They were impressed.

When we got back to Dedham, we drew up the schematic for the "NUT-DAC": the "New Un-Turkey DAC." I have reconstructed from memory what the circuit was approximately like (Fig. 2). MUCH simpler to build, MUCH simpler to trim.

And Frank Dota, the manager of our Drafting Department, used a special pencil to draw, on the schematic, a sketch of a Turkey skedaddling out of an open cage. A fitting label for an "Un-Turkey DAC." And, because Frank used the special pencil, the picture of the Turkey didn't show up on the print when we made a copy. So the customer could look at a copy of the schematic, and we could look at the original, and he could not see what we saw—he could not see the Turkey skedaddling out of the cage.

This DAC was so much easier to build, and trim, that we actually got our shipments back on schedule, and shortly began to turn a little profit. Bob Goodell, our General Manager, called our whole team into his office, and presented me with a 44-lb. Frozen Turkey as a bonus for bailing us out of the Turkey-DAC business. I took this big Frozen Turkey home. We had a big freezer, so we had no trouble finding a home for it. But we could not fit it into our oven.

So my wife took it down to our neighborhood butcher, and she had him saw it in half, and that way we got to cook and eat our Turkey 22 pounds at a time.

That wasn't quite the end of the Turkey DAC, because we thought it would be a lark to present a technical paper on this DAC. I submitted the paper to NEREM (the IEEE's North-East Regional Electronics Meeting), and then presented it in the spring of 1973. I showed the complete circuit, and all the trims, and all the technical

## PEASE PORRIDGE

specs, with a straight face. Really good specs! Afterwards, I overheard a number of people saying that they could not *believe* that a DAC like that could be produced. Well, they weren't *entirely* wrong....

And, that's **STILL** not the end of the Turkey-DAC. An aviator friend of mine pointed out that the Lockheed S-3A is still flying for the Navy, and quite possibly, probably, some of those old Turkey-DACs are up there flying right now.

All for now. / Comments invited!  
RAP / Robert A. Pease / Engineer

Address:  
Mail Stop D2597A  
National Semiconductor  
P.O. Box 58090  
Santa Clara, CA 95052-8090

### BOB'S MAILBOX

*Dear Mr. Pease:*

I also still find analog computers very useful in designing simulators and training devices. One analog computer I designed was a propeller-torque computer. It calculates torque as a function of RPM and pitch, and sends the resulting torque set point to a dynamometer controller in a complete (less propeller) ship's engine room located in a school building. Another analog computer calculates generator speed as a function of time, electrical load, and turbine throttle valve position in an electronic governor trainer.

Both of these could have been done digitally, of course, but the analog design was simpler (cheaper) to design, build, document, and maintain. No software, no a-d or d-a converter. A classic trade-off example: Choose any three—better, faster, cheaper. I don't think digital can come close to the cost-effectiveness of analog for any application requiring analog in and out, and requiring a fairly small number of add/subtract, multiply/divide, and log/antilog terms.

**GLEN WALPERT, PE**  
**Yeadon, Pa.**

*I tend to agree that analog circuits can still have advantages over complex digital or Fuzzy systems.—RAP*

## DEVICE PROGRAMMERS



- \*PC based \$139.95, Parallel port connect \$449.95, Stand alone models \$550.00 or \$750.00 gang
- \*Read, Pgm and verify 2716 - 8 Megabit EPROM, all models
- \*Support for micros, Flash, EPROM, 16 bit, PALs, Mach (call for specific models support list or download demos via BBS or internet)
- \*30 day money back guarantee, **FREE** software updates
- \*Technical support by phone Mon - Fri 8am to 5pm PST
- \***Made in the USA**, 1 or 2 year warranty on all parts and labor
- \*Easy to use menu driven software, on line "help" full screen editor
- \*MACROS, Read and save to disk, Split and set options
- \*Internet ftp://ftp.crl.com/users/ro/needhams

FOR MORE INFORMATION CALL

### NEEDHAM'S ELECTRONICS, INC.

4630 Beloit Drive #20



**(916) 924-8037**

Sacramento, CA 95838

**BBS (916) 924-8094**

(Monday-Friday, 8 am-5 pm PST)

**C.O.D. FAX (916) 924-8065**

READER SERVICE 133

### CheckMate helped Micropolis debug their '186 code.

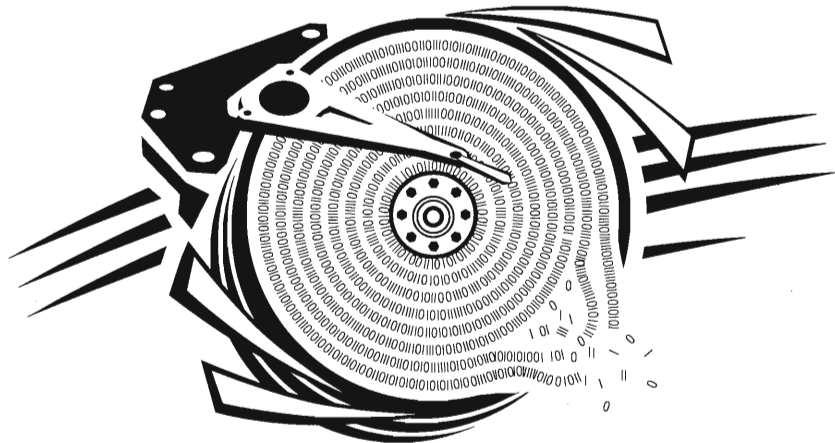

When Micropolis decided to replace their various emulators, they called on CheckMate to ICE their needs. Guaranteed to run in target, at 1/3 the cost of traditional box emulators, CheckMate helps more x86 designs than any other. Make your next design faster and easier. Call CheckMate at 1-206-869-7211.



**CheckMate Systems** Emulation for the masses.  
P.O. Box 3361, Redmond, Washington 98073-3361, FAX 206-861-3647

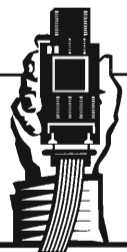

READER SERVICE 94



# WHAT'S ALL THIS "ROBUST" STUFF, ANYHOW?

Recently, some Managerial Experts have suggested that a good designer will plan a "Robust" system or a "Robust" product, a product that conforms to its specifications and requirements, and has low variance. No matter what the raw materials and their variances are, the manufacturing process is so excellent that the parts produced all look the same. (But, hey, lots of good engineers have been doing that for years.) Every field goal goes right between the goalposts. And all you have to do to accomplish this is to invoke the magic words: "The Robust



**BOB PEASE**  
OBTAINED A  
BSEE FROM MIT  
IN 1961 AND IS  
STAFF  
SCIENTIST AT  
NATIONAL  
SEMICONDUCTOR  
CORP.,  
SANTA CLARA,  
CALIF.

Method." In fact, in an adjacent article in this issue, Mr. J. J. King claims that he knows a lot about this "Robust" designing. Now, some aspects of this "Robust Method" sound kind of familiar, like the old Taguchi Methods. But I have yet to find any definition of what "the Robust Method" is. So it is puzzling—Mr. King says I was wrong to criticize the "Taguchi Methods," and proposes that "Robust Methods" are better. But he never indicates what the differences are between the Taguchi Methods and the "Robust Methods." So we're forced to try to guess....

Let's look at Mr. King's points. In the beginning of his article, Mr. King

says that in my 1992 column<sup>1</sup>, I was turned off by my "inability to regulate the circuit." No, back then I was aggravated by the refusal and unwillingness of the Taguchi Lecturer to tell me what the circuit was, or if there was any real circuit whose output voltage was invariant of beta at one optimized condition.

I was nervous, because if the Lecturer's statements were true, *he* could design regulators a lot better than *I* could. If this was so, I wanted to find out this secret before my boss found out how stupid I was. What was this regulator circuit? What was the circuit, which had an output with a curve that went flat and invariant of beta, at beta = 40? Where did this curve come from—the curve that's on the front cover of a Taguchi-Methods textbook<sup>2</sup> or the curve in Taguchi's 1979 book<sup>3</sup>? Of course, after I found out that there never was such a circuit, and after I forced both Genichi Taguchi and the Taguchi Lecturer to admit there never was any such circuit, *that* explained why they weren't in any hurry to tell me what the circuit was.

I actually took the Taguchi seminar just seven weeks before the 1990s, on November 8, 1989. I took notes. I remember it very well. Mr. King says that way back then, "many of the seminars were very poor caliber both in content and delivery." Yes, that's consistent with my notes. However, the Lecturer wasn't just *any* Lecturer, but was endorsed and approved and authorized to teach Taguchi's methods by the ASI (American Supplier Institute), which is the official promoter of Taguchi Methods. Mr. King seems to think we ought to buy *his* arguments about Robust Methods—but why are we supposed to take his word over the words of a lecturer who has been approved by the

ASI? Have Mr. King and his opinions and statements been approved by the ASI? Or by Mr. Taguchi? Is Mr. King an *authorized* spokesman for "The Robust Methods?" Who provided the authorization?

In the very next paragraph, Mr. King says, "The 1979 booklet<sup>4</sup> by Taguchi was written at a time when the initial signal-to-noise ratios were being developed ...his thinking and our understanding of his thinking have evolved a great deal in the ensuing 15 years." Now that may be a fair statement. Everybody has the right to make improvements. Now I'll show you a circuit that was published in Taguchi's 1988 book<sup>5</sup>. Obviously, Mr. Taguchi had nine years to design better, improved, optimized circuits since his earlier books. He had nine years to use his "evolved" thinking to optimize better circuits and make them "Robust."

This circuit uses the same basic schematic diagram and the same basic equations as the circuit that Taguchi presented in his 1979 book (*see the figure*). But it shows the new component values from his 1988 book. He puts in a +138-V dc supply, and he uses his computer to "optimize" the matrix of component values, so as to get an output of 238 V. This is *not* a switching regulator—neither capacitors nor inductors are in this circuit.

Look at the dc voltages. These are the values that the computer gives, after Taguchi puts the circuit into a computer and "optimizes" it. The output of the regulator is +238.6 V. The emitter of the npn power transistor is at +1679 V. The collector of that transistor is at +138 V. The collector current of Q3 is -195 mA, and the collector voltage is up at +1681 V (or higher). Gee, Q3 must be getting cooler by the minute!

Now, I can't make this circuit work, but Taguchi seems to think he can, because nothing in this circuit violates the equations that he wrote and optimized. After uttering the usual platitudes, and writing down all of the equations, he tells the computer to "optimize" the results. When the computer spits out an answer, he says that is a good, optimized answer ...and he walks away without ever checking it. My, what a "Robust" circuit that is!! Yes, Taguchi's thinking "...has evolved



# PEASE PORRIDGE

a great deal in the ensuing 15 years.”

The output voltage  $E_o$  of the regulator circuit is supposedly given by the adjacent equations. Note, these equations aren't literally correct, and can't be derived nor justified, and they give erroneous answers. These are

linear equations, and may give certain minor errors if used in a nonlinear system, such as one with transistors. But these are the equations Taguchi used, and I did copy them accurately. Note, if you want the actual equations for  $E_o$  as a function of all the variables,

send me an SASE. Note, the equation for  $g$  ought to be:  $g = z(11) + z(12)$ . Unfortunately, the equation used was:  $g = z(8) + z(12) = 58.5 \Omega + 0.6 \text{ V}$ . So even if you put in a 12-V zener as  $z(11)$ , the circuit will see 58.5 V at the top of  $z(11)$ .

Near the bottom of the first page, Mr. King believes that calibrating, and checking the zero offset frequently “may not, however, be the most efficient long-term strategy.” Apparently Mr. King thinks, along with Mr. Taguchi, that the “most efficient” method means taking the *minimum* amount of data. Maybe 20 years ago, when computers were expensive and slow, and computation was dear, the best thing to optimize and minimize was the amount of computation.

But these days, computation is not really expensive at all. The human interface, and the cost of recovering from errors, and the possibility of not getting fooled in the first place, all seem to me to be much more important things to optimize.

At the top of the second page of his article, Mr. King observes that the “Robust Method focuses on making systems (including measurement devices) robust,” so that “variation in responses caused by noise conditions is reduced, thus lessening the need for frequent calibration.” Well, isn't that nice. If I have a voltmeter that's as good as I can buy or make, and the noise is *still* as big as the signal, I like to take a *lot* of samples of the signal. I also like to take lots of samples of ground or another appropriate calibration signal, to try to average out the effect of the noise, and get the best signal-to-noise ratio. But Mr. King thinks he can use Taguchi's old methods to take only a *few* samples and still get a superior signal-to-noise ratio.

This new “Robust Method” must be some really good magical stuff if it can supersede Sampling Theory. I'll have to find out who is teaching such a superior way to minimize the noise while taking fewer samples. Mr. King claims at the bottom of the first page that by using “the Robust Method on the equipment or instrument to make it ‘robust’, i.e. insensitive to usage or noise conditions which tend to cause variation, one would not have to recalibrate as frequently as Pease must.” Gee, that

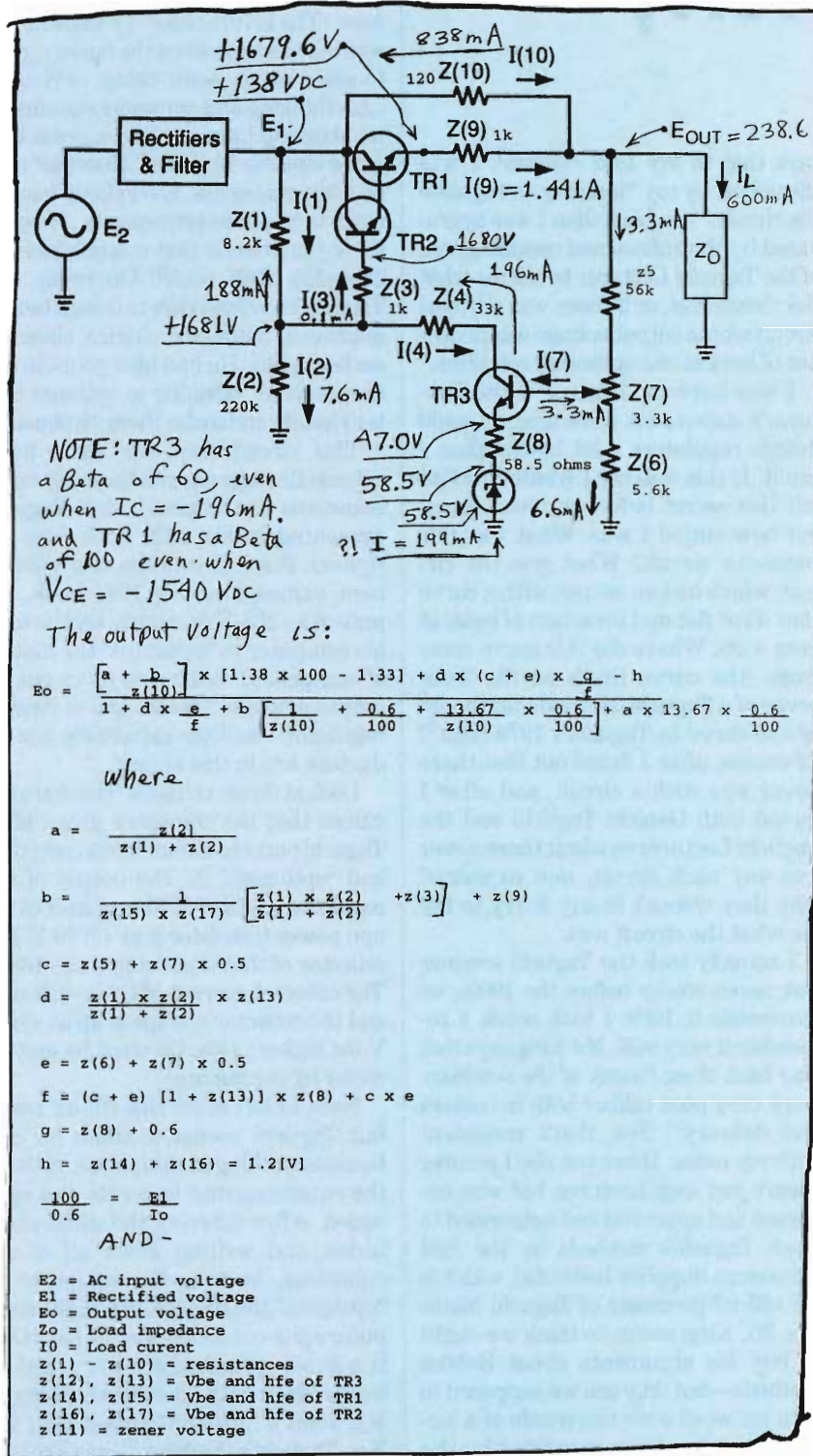

## PEASE PORRIDGE

sounds really neat, to never have to put in frequent autozero cycles, because a "Robust" method is better than autozeroing. Wonder how it does it....

At the top of his second page, Mr. King observes that Pease proposed "compensating", so that a change in the raw material's viscosity would not take the extrusion machine's operator by surprise. Yes, I did. He says that "the cookbook monitoring and adjustment remedy proposed by Pease is an example of thinking that compensation is the only strategy to use to assure good output." Hey, I never said that compensation is the *only* strategy. I just said that compensating for unavoidable changes in viscosity was completely ignored and rejected by the Taguchi Lecturer. I suggested it probably wasn't a good idea to ignore concepts like compensation. I never said that optimizing the process until it rejected variations wasn't a good concept. I just indicated that it might not be enough. Because no real example was presented, but only a *faked* example with *bogus* data, I never developed any confidence that this "robust design" would be anything other than *more bogus thinking*. You show me a guy who makes his living running a press for extruding spoons, and I'll show you a guy who knows his process and doesn't use Taguchi Methods—and probably does not *need* "Robust Methods." He doesn't need *bogus thinking*, either.

"What may be a noise factor to a process engineer (such as viscosity) may be a control factor to a design engineer." Ah, but the Taguchi Lecturer didn't tell us to use viscosity as a control factor. He told us to ignore the viscosity. *RAP* is the guy who proposed to use the viscosity as a control factor! So, that's exactly *my* point.

Again, down near the end of the text, Mr. King guesses that Taguchi *may* want engineers to "study how to reduce variability versus compensating for it." Well, in an integrated circuit, we don't much care what the resistivity is, even with tolerances as wide as  $\pm 10\%$ , so long as the circuit cancels it out. We compensate for the resistivity; we don't try to control its variation to ever-tighter limits. And we make some very good circuits, using circuit compensation techniques

that are well known. For example, we don't *control* the  $V_{be}$  of a transistor, but we *compensate* the  $V_{be}$  of one transistor, at  $2104 \mu V/^\circ C$ , with the  $V_{be}$  of another transistor, at perhaps  $2103.7 \mu V/^\circ C$ . This gives an error much better than  $1 \mu V/^\circ C$ . Go ahead, tell me I should not *compensate*. Tell me another platitude.

Go ahead, tell me that compensation stuff only works in electronics. Go ahead, tell me that in manufacturing of mechanical goods—such as in automobiles—you are better off just to *reduce the variability*. Now, when Ford is making the pistons for a V-8 Mustang, do they make all of the pistons *exactly* the same size, the *same* weight and the *same* diameter, and then put them into cylinders that are all *perfect*? I think not. I think they make matched sets, matched for weight and diameter, using a selective fit.

At least, that's what I read recently. Some guy was arguing that Honda was thriving on "perfect" manufacturing, whereas a simple observation showed that they, too, were carefully fitting and matching their pistons and cylinders in sets. Or, is that passé?

NOW, on to the general topic of Taguchi's 1979 regulator circuit. Even before I built this, I knew that it wouldn't work. I showed a lot of engineers this regulator circuit, with Mr. Taguchi's "optimized" values, and they agreed that it wasn't workable. Other engineers in Japan evaluated Mr. Taguchi's "optimized" regulator, and they, too, knew it didn't work. But, apparently, they decided it wouldn't be polite to tell him this. Nine years later, Taguchi "optimized" another regulator. How did he optimize it? As usual, he just plugged his equations into his computer and let the computer optimize the "Orthogonal Array." The computerized solution provided an npn transistor with a  $V_{ce}$  of +1630 V dc, and a collector current of NEGATIVE 195 mA BACKWARDS (*reversed*). And with a base current that flowed BACKWARDS. And with an EMITTER CURRENT that flowed BACKWARDS. Then he decreed that one could best get Low Variation of the Output Voltage by specifying that npn transistor with a beta of  $500 \pm 10\%$  so as to decrease the reversed base current, which will now

be  $1/500$  of the reversed collector current. I'm glad that "Robust Technology Development" is able to do such a good job of optimizing—much better in 1988 than in 1979. Further, Mr. Taguchi claimed this was an efficient regulator<sup>6</sup>. Well, maybe a regulator that can put out 238 V dc with only a 138-V input seems efficient. But the resistor z(9) has 2000 W of dissipation in it. Such efficiency!!

NOTE: A derivative tells you the *slope* of a function. Taguchi dislikes derivatives, claiming that they're messy and hard to perform, and he doesn't like to clutter up your head or complicate your system analysis with derivatives. But maybe when he claims he has "optimized" a system, he might just try some derivatives to see if there's a slope in any direction that might lead to further optimization. Maybe that would decrease those embarrassing cases where he says he has found an optimum, but hasn't.

When I first started to analyze the 1988 regulator, I was surprised to see that when I simply increased the beta of TR3, that seemed to cause the output voltage to *RISE*. In any proper regulator, increasing the beta of TR3 will cause the output to *FALL*. I got suspicious right away, because a derivative told me that Taguchi's regulator would run better if I went left, when I knew I needed to be further *right*. It took a long time for me to find out that the *RISE* of  $E_{out}$  was caused by the mathematical artifact due to the emitter and base and collector currents of TR3 all being "reversed." I like to change one thing at a time to see what's happening. Taguchi likes to change everything at once, because he thinks that is a more "efficient" way to evaluate in an orthogonal array. Mr. King seems to like the idea of being "efficient." I wonder if he likes to change everything at once in the interest of efficiency. I wonder if he dislikes derivatives.

Further on, Mr. King lists a number of product-development projects where "The Robust Method" has allegedly been observed to work. All very fine. Some are mechanical, some are chemical. These cases may well be nonlinear and unpredictable. I have seen a number of cases where the en-

## PEASE PORRIDGE

gineers were making bad guesses, and after they tried a good Design Of Experiments (DOE), they found clues that led to improved results. I have no objections to DOE; I just prefer to use anybody else's methods, such as Box's or Bhote's, rather than Taguchi's. But Mr. King says, "The Method works and it is powerful." I used to have a farmer friend who said exactly that when his neighbors questioned him about his preference for organic versus chemical fertilizers....

In Mr. King's last section, he poses the *possibility* that Taguchi prefers to "optimize function versus studying actual quality problems." Well, in many cases, you can waltz around with "optimizing the functionality" forever, but you'll never spot and solve a REAL quality problem unless you look for the real quality problem. I'm very weary of these platitudes. If we ever ship a bad IC to Ford, the Ford QC department requires us to take corrective action and look at the "actual quality problem." Just "optimizing the functionality" will not do.

Mr. King then suggests that Mr. Taguchi thinks we ought to "reduce variability." In August of 1993, an engineer from California pointed out that a book<sup>7</sup> published by a European Taguchi Conference showed how to make an audio-frequency filter using one op amp, four resistors, and four capacitors. BUT to get it to meet specs with low variability, the Taguchi expert had to use some 2% resistors and 5% capacitors. Definitely expensive.

But the California engineer was able to get the circuit to meet specs with 100% yield by using four 10% resistors and four inexpensive 20% capacitors. He did it by *thinking*, and by choosing capacitor values that the Taguchi experts had analyzed and rejected. It seems that smart engineers who don't rely on the CRUTCH of Taguchi's methods are able to make a system that's more ROBUST than the Taguchi enthusiasts. They're also able to tolerate larger variations in component values, and cheaper, too. I wrote to the editors of the Conference Journal and to the authors of the paper, asking them why we could design a better yet cheaper circuit than the Taguchi experts recommended.

Was there something about the Taguchi Methods that we didn't understand? They never responded, never wrote back. I guess if you have Robust Technology Development, you don't have to reply to ignorant peasants in California.

Then I studied that filter problem a little more, and I was able to meet all of the specs at 100% yield, using only *two* 2% resistors and only *two* 20% capacitors in a basic Sallen-Key filter. That's a lot cheaper than the 5% capacitors recommended in the Taguchi Book. Now, perhaps Mr. King might argue that "Robust Methods" can optimize the *variation*—the spread or deviation—better than my cheap circuit with two Rs and two Cs.

Excuse me, but I have *NEVER* in 33 years of engineering had my boss or my customer request me to optimize the *variation*. They often ask me to improve the *yield*, or to tighten up the *specifications*, or to increase the *safety margin* by which we meet spec. Improving the variation may be one *means* that I use to accomplish this, but improving the variation is never the *end*. Yet Taguchi proposes that reducing variation should be our *goal*. I guess he and I don't go to the same church.

I'm amused by the notion that Taguchi may propose to "synthesize a new system by maximizing the intended function, versus trying to reduce or compensate for the unintended function(s)." After you hear 1000 platitudes from Taguchi, one more platitude doesn't even make a splash. But, Mr. King, you're supposed to be Ford's manager of Engineering Education. Wouldn't it be better to *educate* your engineers to THINK, rather than just *training* them to follow Taguchi's old cookbook methods? I don't know, you tell me.

Meanwhile, Ford's Quality Engineers have been coming around to NSC and to other semiconductor companies, telling us how to design ICs. They're specifically telling us NOT to just "maximize the intended function," but are requiring us to beware of undesired, unintended side effects of circuits, according to Ford's FMEA (Failure Mode & Effects Analysis). Well, we engineers have been doing this for years, and we agree that's a

pretty good idea. So, Mr. King, if you think that it's a good idea for engineers to just "maximize the intended function," and ignore unintended functions, let us know after you have gotten the Ford Q1 quality engineers to change their minds.

Mr. King never told us what the differences are between the old "Taguchi Methods" and the new "Robust Method." He never tells us where the "Robust Method" is defined—except by using the same old platitudes Mr. Taguchi used. He never gives an example. So I suspect there's a lot of commonality between the two.

All for now. / Comments invited!  
RAP / Robert A. Pease / Engineer

Address:  
Mail Stop D2597A  
National Semiconductor  
P.O. Box 58090  
Santa Clara, CA 95052-8090

P.S. By the way, is there any possibility that "the Robust Method" uses Orthogonal Arrays....?

### References:

1. Robert A. Pease, "What's all This Taguchi Stuff, Anyhow?", *Electronic Design*, June 25, 1992; p. 83-84.
2. Thomas Barker, *Engineering Quality by Design*; Marcel Dekker, NY and Basel, with ASQC Press, Milwaukee, 1990, p. 13.
3. Genichi Taguchi and Yuin Wu, *Introduction to Off-Line Quality Control*, Central Japan Quality Control Association, Nagaya (sic) Japan, 1979; p.30.
4. Ibid. But, I wonder why Mr. King calls it a booklet? It's 8.5 in. by 6 in. with 111 pages—a real book. Why does Mr. King try to minimize the book?
5. Genichi Taguchi, *System of Experimental Design*, Kraus Publications, White Plains, NY, with American Supplier Institute, Dearborn, Mich., 1988; p. 379-389.
6. Ibid., p. 379.
7. *Taguchi Methods (Proceedings of the 1988 European Conference)*, Elsevier Applied Science, London & New York; Chapter 11, "Tolerance Design and Analysis of Audio Circuits", p. 111.



# The Robust Method—A New Way To Engineer

*In our June 10, 1993 issue, we extended an open invitation to Dr. Taguchi or any of his proponents to respond in print to Bob Pease's comments on the Taguchi Method. This article is a result of that invitation. Bob's comments on the article can be found in this issue's Pease Porridge column.—ed.*

**J.J. KING**

Ford Design Institute, Fairlane Plaza  
South, 330 Town Center Dr., Suite 700,  
Dearborn, MI 48126; (313) 322-0999.

# T

he following comments are in response to articles published in past issues of *Electronic Design*. The articles were written by Mr. Bob Pease regarding Taguchi methods. The specific articles are: "What's All This Taguchi Stuff, Anyhow?" (June 25, 1992, p. 83-84, and "What's All This Taguchi Stuff, Anyhow? (Part II)" (June 10, 1993, p. 85-92).

To summarize Mr. Pease's key points: In the 1992 article, Mr. Pease indicates he took a Taguchi Method seminar a "couple of years ago." The lecturer was a professor at one of the "respected eastern technical schools." Mr. Pease was turned off by the following:

- The claims made in the lectures.
- The lack of response to the letters he sent to the lecturer outlining questions related to the Taguchi Method discussion in the seminar.
- His inability to regulate the circuit when he tried to duplicate Taguchi's 1979 booklet example.

*Historical Timeframe Background*—To understand the context of the discussion in Mr. Pease's articles, it's helpful to keep in mind the timeframe of events.

- During the late 1980s when Mr. Pease took the seminar, there were a number of instructors teaching Taguchi Method seminars. The technical content focused on static quality formulations versus the more powerful physics-based dynamic formulations developed since then. By today's standards, many of the seminars were very poor caliber in both content and delivery.

- The 1979 booklet by Taguchi was written at a time when the initial signal-to-noise ratios were being developed and his thinking was being translated from Japanese for the first time. His thinking and our understanding of his thinking have evolved a great deal during the ensuing 15 years.

*Comments on Key Issues*—The following comments address some of the statements in Mr. Pease's articles.

*Pease ('92 article):* From the seminar, the Method implies, for example, that you should not check the reading or gain on an instrument or piece of equipment very frequently, since that would be wasteful and redundant. Mr. Pease criticizes this implied recommendation since experience has taught him that most equipment has drift tendencies and "jumpy" habits. Thus, technicians should "keep their eyes on the experiment" and "normally repeat some of the early tests down near the end of testing."

*Comment:* Essentially Mr. Pease says that it makes sense to calibrate frequently to account for laboratory or other customer usage conditions that cause variation. It's definitely a sound strategy and one that will work. It may not, however, be the most efficient long-term strategy.

By using the Robust Method on the equipment or instrument to make it "robust," i.e. insensitive to usage or noise conditions which tend to cause variation, one would not have to recalibrate as frequently as Pease must. Mr. Pease's approach and the Robust Method are different strategies. Pease accepts response variation caused by usage conditions and tries to compensate for it by frequent sampling to assure representative test measurements.

The Robust Method focuses on making systems (including measurement devices) robust. Therefore, variation in responses caused by noise conditions is reduced, thus lessening the need for frequent calibration. If one needs to recalibrate due to some noise factors, the more robust the system, the easier the recalibration effort.

*Pease ('92 article):* In the case of manufacturing plastic spoons, the Method determines an optimal setting for time, temperature, and pressure. With the Method, "there are no plans to keep track of viscosity and its changes, or compensate for it.... Suddenly, a new batch of plastic comes in with a much lower viscosity. Are the optimums going to change? You bet! And if I keep monitoring the viscosity, I can look up in my cookbook to see where I should start searching for a new optimum." Mr. Pease believes his approach is obviously better than the approach presented in the seminar.

*Comment:* We would agree that keeping track of the quality of incoming material is appropriate and we do this at all of our Ford plants. However, the cookbook monitoring and adjustment remedy proposed by Mr. Pease is an example of thinking that compensation is the only strategy to use to assure good output. It focuses on using only one tool. It ignores other potential strategies. If done exclusively, without first considering how to make the process insensitive to incoming material viscosity (i.e. conducting parameter design), it may not result in the most optimized process. After all, doesn't the process engineer prefer a process that can tolerate incoming material variation and still produce consistent parts? Shouldn't parameter design be tried first? Mr. Pease may have missed the point. It's preferable that noises such as viscosity variation to a process need not be controlled or compensated for in the plant. If viscosity is a dominant noise factor and the engineer is unable to develop robustness against it, another appropriate strategy needs to be considered, such as compensating or controlling it.

*Memo:* For those familiar with the Robust Method, determination of whether a factor is noise or control depends on the engineer's perspective. What may be a noise factor to a process engineer (such as viscosity) may be a

control factor to a design engineer.

*Pease ('93 article):* The circuit in Dr. Taguchi's 1979 booklet reduced output variation from  $\pm 25$  V to  $\pm 1.5$  V, and exhibited little output variability with bad-tolerance resistors. "Even if the reference voltage had a tolerance of 5 or 10%, the circuit was so well optimized that the output was still more accurate than 2%." Mr. Pease's criticism is that when he built and tested the circuit himself, it didn't work, i.e. it didn't regulate. Mr. Pease recognized that Dr. Taguchi's article stated that the circuit optimization was only applicable to a single fixed input voltage condition and that line regulation wasn't considered. In spite of recognizing that, Mr. Pease criticizes that the circuit was never built by Dr. Taguchi, didn't regulate when Pease built it, and thus is a meaning-

## D R. TAGUCHI RECOMMENDS THAT ENGINEERS STUDY HOW TO REDUCE VARIABILITY VERSUS COMPENSATING FOR IT.

less example of the application of the Method since it's not an example of a "real" operating system.

*Comment:* From reading the 1979 booklet, the purpose of the electronic circuit examples was to show that parameter design was an effective tool in reducing output voltage variation (with a fixed input) and reducing the associated economic loss. Dr. Taguchi attempted to show how to use an orthogonal array to lay out an experimental design to carry out parameter design. In hindsight, it may not have been the best example to use. The Robust Method, thinking in terms of dynamic formulations (ones with varying input, such as a regulator circuit that regulates for varying input signals), wasn't developed at the time. Today, that thinking is known

as Robust Technology Development.

*Other observations:* There is no one best way to engineer that can handle all the variety of today's engineering issues. However, my on-the-job experience with Robust Method case studies on actual hardware indicates that the Method can be successfully applied to a wide range of automotive applications, including production, design/development, and research. Some of the areas where the Method has been successfully applied at Ford Motor Company include the weatherstrip, seat track attachment, engine mass air-flow sensor, transmission one-way clutch, engine idle performance, steering system, fuel systems, wiper systems, the windshield glass manufacturing process, the vehicle toe setting process, and others. *The Method works and it is powerful.*

At the end of the 1993 article, Mr. Pease indicates that the response he received from Dr. Taguchi stating, "We are not interested in any actual results because quality engineering deals only with optimization," seemed illogical. At first reading, this response may seem that way, or even off-handed or abrupt. My experience working with Dr. Taguchi is that, while it could have been stated differently or perhaps more fully, there's a solid basis for his response. The real interpretation might be that Dr. Taguchi recommends that engineers:

- study how to optimize function versus studying actual quality problems.
- study how to reduce variability versus compensating for it.
- use parameter design to study how to optimize.
- synthesize a new system by maximizing the intended function versus trying to reduce or compensate for the unintended function(s).

*John J. King is manager of engineering education at the Ford Design Institute. He holds a BS in Engineering Science from the University of Detroit, an MS in Bioengineering from the University of Michigan, and an MBA from Michigan State University.*

HOW VALUABLE?	CIRCLE
HIGHLY	689
MODERATELY	690
SLIGHTLY	691

## PEASE PORRIDGE



# BOB'S MAILBOX

### Dear Mr. Pease:

I enjoyed reading your article on GPS devices in the Oct. 25, 1994 issue. This did not surprise me since I enjoy most of your articles.

For over 14 years I have worked at Standish Industries, a domestic manufacturer of LCDs. As you undoubtedly know, this product name comes from the descriptive phrase Liquid Crystal Display. In your article, I noticed two locations where you referred to the display of your GPS receiver as the "LCD display," or liquid crystal display *display*.

I imagine that if I worked with LED diodes or CRT tubes, I might not have noticed any irregularity. Unfortunately, I do not and I did. I hope you do not mind the critique.

**RALPH SABROFF**  
*Applications Engineer*  
*Standish Industries Inc.*  
*Lake Mills, Wisc.*

*Hi, Ralph—it's funny you mention this. I just saw a promotion for "LED diodes." I agree, I dislike gratuitous redundancy like "pizza pie" or "The La Brea Tar Pits." Next time I will say "Liquid Crystal Displays (LCDs)" the first time, and "LCD" or "the display" in subsequent usages. —RAP*

### Dear Bob:

I've been waiting for three years to write this letter. I always read your column and like the fact that you consider a person's ability to be more important than a sheepskin hanging on the wall. I have read with great empathy the letters you get from other "non-degreed Engineers." This is because I, too, am a "non-degreed Engineer." But this letter is not to lament about the discrimination toward our kind but to claim victory! Yesterday, I received notification that I passed the Electrical Engineering exam I took in October of 1994. I am now a Registered Professional Engineer. I can use the title "Engineer" to the general public, which is something that an

"Engineer" with only a degree cannot. Am I gloating here? Maybe just a little.

What I really want is to let other talented people out there, who for one reason or another never got a degree, know that there is an alternative to spending every spare moment of time for the next six years in school. They, too, can get their license and be a registered engineer. All you need to do is pass two eight-hour exams. The first is the E.I.T. (Engineer in training). The second is the actual Engineering exam. The only prerequisite is that you have at least six years of qualifying experience in your field. For each of the tests, I prepared by taking a review course offered by a local company. They run for 14 weeks prior to the test, and you attend a three-hour class just one night a week.

So for a total investment of about 28 weeks of my life, I now have the title of Professional Engineer. Granted, it wasn't the easiest 28 weeks, but it was worth every minute. So let your fans know there's another way to earning the respect they deserve. Become a P.E.! If I did it, they can do it too!

**DAVID GOODIN**  
*San Jose, Calif.*

*David, What's All This Professional Engineer Stuff? I'm looking into this. And congrats!—RAP*

### Dear Mr. Pease:

Actually, some multi-turn trimpots are even "worse" than you described ("What's All This Dead-Zone Stuff, Anyhow?", Feb. 6, 1995, p. 123). The ones I'm using in one of my products consistently display an even nastier characteristic when you are trying to make a careful adjustment to a set point. When adjusting the pot (even when going slowly), if you overshoot your set point and then carefully reverse directions, in addition to the dead zone you need to go back through, these pots will show a slight initial "backwards" value change before the value goes in the expected direction. My best guess is that the

wiper assembly on the lead screw in the pot slightly changes angle when it changes direction, causing it to make the slight initial "backwards" change in value before it begins moving in the right direction.

This funny nonlinearity could really give a control system fits! Humans can adjust to it pretty quickly, though. Perhaps fuzzy logic would be required (tongue in cheek).

I would guess that the pots from the many other manufacturers who make similar-style parts to the ones I'm using also show the same properties. This problem and the other advantages of single-turn pots that you described in your column are the price you pay for having the lead screw system in the part, as opposed to the "direct drive" system in the single-turn pots that has no gear backlash.

Before I ship my products, as part of the final checkout, I smack each board down on the test bench (while under power) so the trimpots take a final set. Then I can verify that the product still makes spec.

**PAUL TITCHENER**  
*Power Technology*  
*Brisbane, Calif.*

*Yeah, some makers' parts are worse than others. I never did like those. —RAP*

### Dear Bob:

Your recent article on dead-zone and pots with infinite resolution struck home. We have discovered, as you have, that 20 turns of mechanical resolution across a 1/2-in. resistive element does not equal 0.1% resolution or even 0.5% resolution.

As I read the article, a thought came to mind of the "pot" that would give a 0.001% settability. I dug through some of my WWII junk in the barn and dug it out. This pot has approximately 12 feet of resistance element, which equals 144 in. for 15 turns of the shaft. If each turn is divided into 100 dial divisions, the slider will move approximately 0.1 in. on the resistor



# PEASE PORRIDGE

element for each dial division. This is a lot better resolution than trying to resolve 1/2 in. of resistive element over 20 turns.

This is probably as close to infinity as we will ever get.

**SHERMAN WOLF**

**Phase One Development Corp.  
Newton, Mass.**

*Sherman, I took your 0.1%-linear Beckman Helipot, model SB42, 3 in. x 3 in. x 3 in., and applied 20 V. I could just about set the output to any desired millivolt. So—about 0.005% resolution—but not 0.001%!—RAP*

**Dear Bob:**

Your recent article entitled "What's All This Designer Stuff, Anyhow?" (Jan. 9, 1995, p. 129) got me thinking about how to go about doing good designs and inventing things. One of the principles of design that has helped me over the years is what I call the synergy principle of design. Once you know a lot of existing designs and talk to your colleagues, and fiddle with pen and paper and try things in the lab, you often find a single part of your design-in-progress that seems to do several things well at one time. This synergy allows a simple configuration of parts, for example, to solve more problems than it has parts in it.

Let's say a batch of six parts has the right function, good thermal characteristics, junction matching, beta tolerance, won't saturate easily, flexible input and output characteristics, and uses your current IC process. Eight problems solved with six parts—good synergy! Often, I would look for just this kind of configuration to pop up during the design process and then make it the cornerstone of the design. Good things usually seem to evolve after that. Also, the synergy often is not obvious immediately to anyone but the designer who has been absorbed in the design quest for a while. This non-obviousness makes for good patent applications.

**ANTHONY E. ZANK**

**Simi Valley, Calif.**

*Anthony—I always thought of this as educated serendipity. When a good invention pops up, I must recognize it and grab it. Most kids aren't too good at this.—RAP*

**BEST IN TEST ELRAD '94**

More than **11,000** Users

## HOW INTERACTIVE IS YOUR BOARD STRATEGY



ULTIboard, one of the leading PC based design systems, is supplied worldwide via a network of ULTIimate Technology offices & distributors. ULTIboard's success with professional designers is primarily due to its superior interactive functionality.

REAL TIME Placement Help, REAL TIME Design Rule Check, Reroute-While-Move and Trace showing, are all features which will dramatically reduce your design time.

Integration with ULTIcap guarantees smooth data flow between Schematic and PCB editing. The inclusion of third party netlist interfaces ensures ULTIboard will fit into any design environment.

Another of ULTIimate Technology's strengths is our flexible growth path. Users may start with a low cost ULTIboard Challenger and grow, step by step, to a 32-bit Advanced Design system including Ripup and Retry Autorouting.

ULTIimate Technology also looks after existing users. With valid maintenance they will be upgraded to a new system based on their original investment. For instance, a 1987 ULTIboard-DOS system has now been upgraded to a 32-bit Advanced system with 2 Autorouters. Regular User Meetings and -Surveys result in 2 major Updates per year.

Your move	ULTIboard's move
☐ YOU want the best placement	☐ In addition to dynamic rats nests, force vectors and density histograms, ULTIboard's <b>Direct Reconnect</b> instantly displays the shortest possible connections. <b>Automatic Gate- &amp; Pin Swap</b> with full <b>Backannotation</b> guarantee the best.
☐ YOU use SMD Technology	☐ ULTIboard understands the different soldering techniques that apply to SMT. Flip your SMD to the other side of the board and ULTIboard automatically applies the pad definitions for either wave or reflow soldering.
☐ YOU want 100% design integrity	☐ ULTIboard <b>Real-Time DRC</b> does not allow you to accidentally connect wrong pins or violate trace clearances. It always respects your design rules.
☐ YOU want 100% automatic routing	☐ The ULTIroute GXR Ripup & Retry Autorouter is able to remove connections that cause a block and automatically reroutes the removed connections. The user can define the Autorouter parameters.
☐ YOU don't want Autorouters	☐ ULTIboard's acknowledged powerful interactive features s.a. Reroute-While-Move and Trace-Shoving under <b>Real-Time DRC</b> guarantee flawless designs in the shortest time. But for non critical traces you can use our second Autorouter which blends in with your manually routed traces to allow you to route per net, component or window.

**Now network version!** The ULTIboard Designer Series (32-bit Schematic Capture & PCB-Layout system with 2 Autorouters) are now available as 'Floating License'.

**ULTIboard Entry Designer NW2; Design capacity: 1.400 Pins**  
**Introductory offer until May 31, 1995 US\$ 2.795**  
**2 User Network Version. Additional Users US\$ 657**

The Entry Designer Standalone systems are also on special offer until May 31, 1995: US\$ 1.690. Also available is a full function Evaluation System (as described above, with a 200 pin design capacity and including Introduction and Tutorial manuals) for only US\$ 40 excl S&H/Tax).

## FROM CONCEPT TO ARTWORK IN 1 DAY

ULTIimate Technology not only adds value to your investment in a ULTIboard system but backs it up with the highest quality support from our 37 distributors and offices.

For a free DEMO version, please, call Ultimate Technology from:	Finland 99031	800-5-900	CALL FREE
	Deutschland 0031		
	Netherlands 0031		
	France 1931		

From **USA & Canada**: tel. 1-800-2676631 (fax 519-6512259), other countries: tel. ++31 2159-44444  
 Or pass your request by fax at ++31 2159-43345 indicating: Company name, surname, address, phone and fax number.

**DISTRIBUTOR INQUIRIES WELCOME at our Corporate Headquarters.**

Technical support from multinational Company established in 1973. Local duties (non EC) and/or sales tax may apply. ULTIboard, ULTIcap and ULTIimate are (registered) trademarks of ULTIimate Technology B.V./Ltd./GmbH/Corp. All trademarks are of their respective companies.

**ULTIIMATE TECHNOLOGY** Corporate Headquarters: Energiestraat 36, 1411 AT Naarden the Netherlands, tel. (+31) 2159 - 44444, fax 43345 Intern. Reply number 464, NL 1400 WC Naarden (no postage required)

READER SERVICE 88

108

ELECTRONIC DESIGN/APRIL 3, 1995

# WHAT'S ALL THIS DIABETES STUFF, ANYHOW?

**F**ifty years ago, I figured out that sugar tasted very interesting and good, so it didn't come as any surprise when I was told that I had contracted a little case of Diabetes. I mean, when I discovered that toast tastes better when you put cinnamon and sugar on it, that's one way to make some good flavor. But if you leave out the cinnamon, it still tastes pretty good. Then, you leave out the toast....

A spoonful of confectioner's sugar, mixed with a little cocoa, tastes great. So does any kind of chocolate, or any kind of fruit, or cake, or pie, that contains sugar. So,



**BOB PEASE**

OBTAINED A BSEE FROM MIT IN 1961 AND IS STAFF SCIENTIST AT NATIONAL SEMICONDUCTOR CORP., SANTA CLARA, CALIF.

As recently as 72 years ago, if you got diabetes, that was a death sentence. Insulin wasn't known, so if you had too much sugar in your blood, and your pancreas wasn't making enough natural insulin, you were sliding down the slope to die. Not fun. But around 1922, insulin was discovered, and the manufacture of insulin from pigs soon became a large, life-saving industry. One injection of insulin per day, and the diabetic person doesn't

die. The insulin helps your body burn the sugar in the blood—helps regulate your metabolism.

In my case, the dietitian didn't give me insulin, because I had a fairly mild case—that is, type II diabetes. She told me to cut down VERY severely on sugar in all its forms, such as soft drinks that typically contain 6 teaspoons of sugar per can, and cranberry juice, and a whole bunch of "dietetic" foods that have less fat, but more sugar.

This is a very NONLINEAR game, though. I was told that I should cut down on my consumption of rice and potatoes, which are starches, or carbohydrates, that contribute a lot to your blood-sugar level. But I should still make sure to eat *some* of these carbohydrates. Eating too much is not good; eating too little is not good. What an odd surprise! I'm glad I'm used to working with nonlinear effects....

Well, I figured that if I couldn't eat sweets, I could still eat interesting spicy or greasy foods. But, when I began checking over some of the literature, I learned that I'm supposed to cut down on fats, too. Not necessarily zero fat consumption, but I had to cut down a lot. Again, here we find a nonlinear situation: If you're overweight, you can have a good amount of insulin in your blood, but your cells won't take it in for some obscure reason. So, it's a good idea to take off excess weight through a good 2000-Calorie-per-day diet PLUS some exercise. Well, we already had a couple of Exercise Bicycles around the house, so I'm doing about 10 miles daily. I cycle away while I'm reading the Chronicle in the morning, so it doesn't take lots of time out of my schedule. I've taken off about 14

pounds already, and more to go. No problem.

What if I didn't do all of these things to minimize the effects of diabetes? Well, if you keep throwing sugar at your pancreas, it will get unhappier and unhappier, and it will put out *less* and *less* insulin. After a while, your insulin supply will completely poop out, and then you will really feel lousy. What happens if you don't get the hint? Very frequent urination and thirst, and feeling generally lousy, are the more obvious clues. But if you ignore these, you can get sores on your feet and legs due to poor circulation. In the worst case, you might have to have a leg amputated. Your eyesight goes to pot due to excess pressure in your eyeballs. Meanwhile, your pancreas works more and more poorly. Pretending you don't have a problem just makes things worse. So, if you have some of the symptoms of diabetes, check it out.

What are the warning signs of diabetes? The American Diabetes Association points out that a sudden loss of weight, sores on your legs that won't heal, weariness, and frequent need to urinate are clues. In my case, my doctor spotted it before the diabetes got too advanced. In my once-every-five-years annual checkup, one clue was that my blood-sugar level was slightly higher than normal. Also, there's a natural substance in the blood—if the blood sugar stays abnormally high for a while, this substance can be tested to show the history of high blood-sugar level. It told on me, and that was a good early warning.

How can you avoid getting diabetes in the first place? Don't eat too much sugar. Eating six Hershey bars per day is probably not so good for you. Don't be overweight. Eat plenty of fruits and vegetables, and not too much starches. Exercise regularly, working hard. All of the things you ought to be doing for good health, anyhow. And, choose your parents wisely....

I was introduced to a technician who showed me how to take a little \$50 meter and measure my blood-sugar level, four times a day before every meal and before bed, using just one



## PEASE PORRIDGE

drop of blood. I confirmed fairly soon that if I didn't eat any excessive amounts of rice or potatoes, nor any sugar, I could keep my blood sugar at very reasonable levels. After a while, I didn't have to take a blood-sugar test more than four times per week. Not a bad deal.

The meter, which is manufactured by LifeScan (a Johnson and Johnson company) works with a little piece of chemically treated paper. After you apply one drop of blood to this paper, the meter shines an LED on the paper, indicating on a little liquid-crystal display what your blood-sugar level is after a 45-second analysis. It stores the reading in memory, e.g., 118 milligrams per deciliter. It's a neat machine that can run on small alkaline batteries for six months. It has one VLSI analog/digital chip, an EPROM, 8 SOT transistors, and several tiny Rs and Cs. Well-engineered, easy to use.

SO, while I still have to be careful and not eat stupid things, I only have minimum problems because my doctor caught this before I wrecked myself. (One time, as an experiment, I ate a big brownie *and* a big piece of cheesecake. Five hours later, my blood-sugar level was 50% higher than normal—obviously, you can't fool the chemistry, and you can't fool the meter. It's not very smart to try to outsmart Mother Nature.) However, I have found that if I'm working hard, (hiking or backpacking) I can eat a Brownie in eight little installments and my blood-sugar level doesn't even show a blip. It's like when you throw a rock into a quiet pond, you see big ripples, but when you throw a rock into a rushing stream, the ripples disappear without any trace. So I can eat a little bit of sugar. But I try not to overdo it.

So far, I have not had to take any insulin, and if I shape up, I may never have to. If I get my weight down, the problem may virtually go away. Right now, my weight is around 207 lb., and still dropping gradually. When I hit 190, I will consult with my doctors and technicians again. Someone will surely say, "Bob, you must feel a lot better since you have lost some weight." My reply is, I felt darned good, and hiked hard and ran upstairs fast when I weighed 230 lb. a couple

years ago. I don't feel any better nor any worse now. It's just intellectually, I must admit, weighing less is good for me. But I haven't been out of work sick, not one day in the last 20 years.

Can I still go hiking? Backpacking? Oh, yes—those are some of the best kinds of exercise, things I can do to take weight off and keep it off. Really, I do NOT have to diet until I turn into a 127-lb. weakling. (FAT chance of that.) So, the situation isn't bad.

Now... I *used to* love to dine at a Thai restaurant and eat some excellent spicy sauces on about 3 cups of boiled rice. OOOOOooh, glorious. But now, if I stop at 2.2 cups, that's much better for me. Someday, even 1.7 cups of rice may fill me up cheerfully. So, I'm headed in the right direction. Taking care of my diabetes problem is really only a very minor distraction. As some people have said, if you had to have a disease, you could pick a LOT of diseases that are a LOT worse than diabetes. Don't feel sorry for me.

Other nonlinear deals: Eating an orange or an apple is good, but drinking orange juice or apple juice isn't very good. You can buy coffee lightener that is fat-free, and sugar-free to lighten your coffee—but I think it tastes lousy. Grape Nuts is a very well-recommended breakfast cereal—but you can only eat 9 tablespoons of it for breakfast. Likewise—oatmeal is supposed to be good for you—but only 9 tablespoons (before cooking). Sweet potatoes aren't good, but yams are. Broccoli and carrots are good, but peas and corn have carbohydrates and aren't so good.

I have even read that apple pie or cherry pie are bad for a diabetic because they have a lot of sugar in them, but pumpkin pie isn't bad. I think that's baloney, because most pumpkin-pie recipes have a full cup of sugar in them. So, I don't have to believe EVERYTHING I read.

Needless to say, there are a hundred ways for sugar to get into a food, and you have to get very skeptical. I mean, when the first (major) ingredient in a cereal is wheat, but the second one is brown sugar, and the third one is fructose, and the fourth is corn syrup, and the fifth is sucrose—you begin to see how the cereal could eas-

ily be half sugar!! Some foods are labelled "dietetic" because they have fewer calories, but all of the calories in them are from sugar! Beware of labeling! On the other hand, some kinds of Yogurt, sweetened with Aspartame, are OK—even though the label says there's a lot of sugar in there—because it's *milk sugar*, and that is OK. When I was a kid, during WWII, we didn't have a lot of sugar, so I never learned to eat cereal with sugar. I always put salt on my oatmeal rather than sugar. Maybe that's the only smart thing I did, even though too much salt isn't good for you either.

A couple of my friends have read the draft of this column, and they already decided to make some sensible changes in their diet by not eating so much junk food. Hey, an apple does *not* make a bad snack. Maybe a word to the wise will help some of YOU overweight guys out there, too?

One of my colleagues read the early draft, and he accosted me in the hallway: "Bob, I *resemble* that guy in your column." I looked at his tummy. I said, "Tom, you *are* well-padded, but I know you. You are a beer drinker. You don't eat a lot of sweets, do you?" He replied that he didn't. I asked, "Does diabetes run in your family?" He said no. I told him, "Tom, the man who was born to hang will never drown. *You* probably do not have to worry a lot about diabetes. But you might want to watch out for heart disease, or your blood pressure, or your liver. After all, you and I want to take pretty good care of ourselves so we will outlive all of those young kids. A check-up every once in a while will not do a lot of harm. And you could probably fit in some exercise while you are reading or watching TV—it might be almost painless to take off a few pounds." You come to your own conclusions.

All for now. / Comments invited!  
RAP / Robert A. Pease / Engineer.

Address:  
Mail Stop D2597A  
National Semiconductor  
P.O. Box 58090  
Santa Clara, CA 95052-8090



## PEASE PORRIDGE



# BOB'S MAILBOX

### Dear Bob:

I had a '66 VW and drove it to Chicago in the wintertime with the wife and three kids in it! That year the round trip gas bill was \$37.50. Gas was only 22 cents in St. Louis. I learned to keep the momentum up. Coming down one big hill in Arizona, I kept it under control. But as I neared the bottom, I realized I would have to pick it up to get to my cruise speed. I floored it and the speedometer went past the 80 MPH mark all the way around back to 15 MPH! I thought it would drop back on the level, but it didn't. I went past a guy in a Mercury as if he were standing still! Later, I went into a gas station and he followed in behind. He asked, "How fast will that thing go?" I said "I don't know, I haven't had it wide open yet!" You wouldn't believe the look on his face.

Coming back in headwinds, I could hardly get it to 60 MPH. I have seen a few accidents where the front gas tank was hit and people burned up in the car, so there is that. This model had a two standpipe drain. I forgot and left it on the low tap and the wife took it out, and it stopped in the middle of traffic. What would the poor woman do? She turned it to the high tap and it took her to the gas station. Got to wondering how this could be. What happens is that gas sloshes around and fills up the high pipe. That is enough to take you at least 1 mile!

**GLENN H. WIXON**

*Sunland, Calif.*

*Yes, VWs do let you know about headwinds—and crosswinds. Myself, I carry a spare gallon of gas.—RAP*

### Dear Bob:

RE: "What's All This GPS Stuff, Anyhow?" that appeared in the Oct. 25, 1994 issue. Sorry about the delay in making these comments, but we procrastinators are an irresponsible group.

At any rate, those of us who for various reasons have looked closely at the GPS appreciate your cautionary comments. There has been way too much fluff in the press and user expecta-

tations have been raised to an unachievable level. For instance, some of your suggested applications can be achieved, such as denoting which mountain is which, and getting to a desired lake. But getting to a specific part of that lake will not work.

With Selective Availability (SA), the GPS repeatability is not  $\pm 100$  meters, even as you suggest. It is really  $\pm 300$  meters. So your actual position uncertainty is 600 meters. If Murphy's Law was in effect, you could mark a fishing hole or a joint on the trail and come back 600 meters away—and walking that could put you in a ravine. There is no way one could repeat way points or follow a trail. Even worse, your perceptual position uncertainty is 1200 meters p-p, in that if you are 300 meters west of the true position, and you are informed enough to grasp the  $\pm 300$  meters spec, you don't know you are 300 meters west. All you know is that you must be within  $\pm 300$  meters, therefore you have to "search" 300 meters even farther west. Or, you certainly would miss your favorite fishing hole.

And all of the above is if the system is working correctly. You could be getting satellite signals for hours at a time that were wrong, giving unspecified position errors. Unlike a true navigation/position-fixing system, the GPS was really designed as a weapons delivery system (in spite of its name) and has no real-time signal integrity monitoring/user notification capability. Or, the number of satellites could have been reduced to 21—not the 25 we are lucky enough to have today. This number may not be enough to give continuous information, especially in situations where some of the signals might be occluded by mountains or foliage, and certainly not in urban environments among buildings.

On a larger scale, the DoD only promises 21 operational satellites for 98% of the time. But in their promise, time is not well defined and what you get during the other 2% is undefined. So let's hope you are not in the wrong place

at the wrong time. Not to worry...DoD will give you 48 hours notice of any change of signal format that could cause a receiver malfunction; but no one has defined how to get the message to you! Also, electronic equipment you might be carrying—radios, cellular phones, PCs, as well as VORs, TV stations, etc.—can cause interference to the GPS under certain circumstances. And GPS can be very easily jammed, which makes one wonder why we U.S. taxpayers paid over \$10 billion to develop and deploy it; and \$500 million every year to operate it. Now the FAA says it will be great to fly with and even do precision landings. If they do, I'm not going!

However our government has a way of always holding out a helping hand to overcome problems, usually by spending taxpayers' money. The USCG is deploying a network of beacons to provide the missing integrity signals and the corrections to overcome SA. Also, the FAA is deploying satellite-based systems to do the same thing for another \$1.0 billion or so, plus yearly operating costs. Of course, neither GPS augmentation (their term) is a separate navaid, as would be VOR or Loran. Neither will get the GPS through foliage, or into urban areas, or around mountains. Nor will either overcome the jamming/interference problem. But you will need a new GPS receiver to handle the FAA messages, plus a new beacon receiver to handle the USCG-generated augmentations.

All of this gets back to operational capability, in most cases already exceeded in the U.S. by Loran at a cost of \$17 million (that's million, son, not billion!) a year. So it took up to now to tell you that I'm a Loran advocate—but not a GPS opponent. The fact is that GPS is here, for mostly political reasons, in that no one wants to admit that U.S. taxpayers have spent all this money, and the GPS is neither an adequate military system (why didn't the helicopter that "strayed" into North Korea use it?), nor a functional civilian

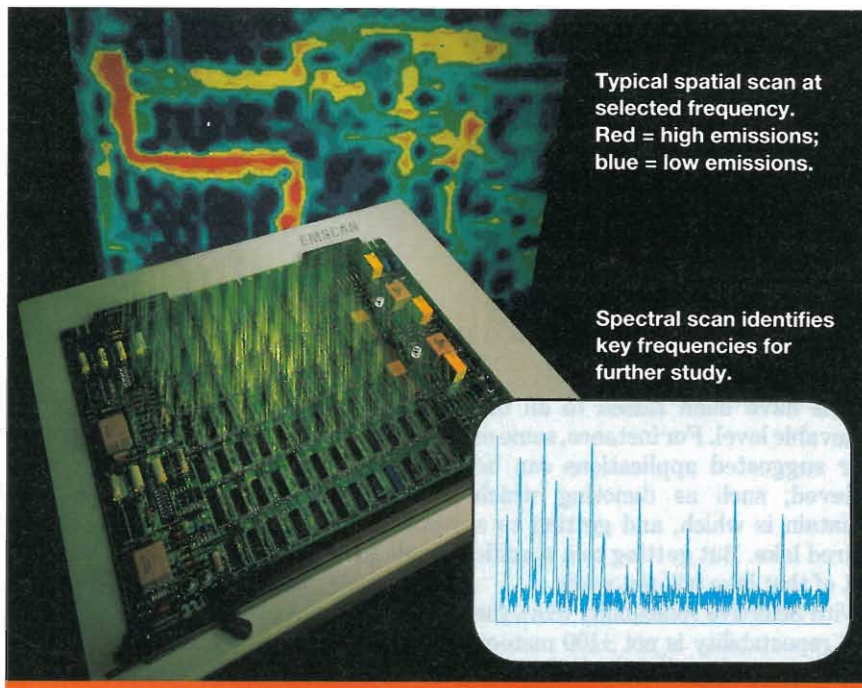

Typical spatial scan at selected frequency. Red = high emissions; blue = low emissions.

Spectral scan identifies key frequencies for further study.

## Catch rf emissions problems at board level, where compliance fixes are least costly.

Now you can quickly get a color image of the electromagnetic performance of your printed-circuit board or subassembly *before* final compliance testing. Spatial and spectral displays generated by the EMSCAN PCB emissions scanner show you which frequencies and which areas of the board under test are guilty. These scans are stored for later comparison after design alterations, to check whether offending emissions are now down to acceptable levels.

Just plug your receiver or spectrum analyzer, and your computer with IEEE-488 interface, into the EMSCAN scanner, and a matrix of 1280 H-field probes maps the area of your test board (up to 9" x 12") for high, medium, and low-emissions spots within the 10 MHz-1.5 GHz frequency range. Or you can see a spectral display showing the overall condition of the board across the spectrum. You may then choose a frequency of particular interest for

intensive spatial examination.

After the development stage, you can use EMSCAN as a quality-control tool, checking completed boards against a "good" scan before they go into assembly. This is the point where production compliance becomes virtually assured.

The software operates under "Windows" to make early diagnosis easy, even for those who are new to compliance testing. It can run on several PCs and workstations, and is readily ported to other environments for analysis.

You should learn all about this qualitative and quantitative measure of emissions for use during product development—where design corrections are least costly. To start, call toll-free (1-800-933-8181) to speak with an applications engineer and arrange to see a demonstration in your office or plant.

**NEW!**  
Frequency response  
now extended to  
1.5 GHz.



160 School House Road  
Souderton, PA 18964-9990 USA  
215-723-8181 • Fax 215-723-5688

For engineering assistance, sales, and service throughout Europe, call  
EMV • Munich, 89-612-8054 • London, 908-566-556 • Paris, 1-64-61-63-29

READER SERVICE 190

12140

## PEASE PORRIDGE

system. But, it will be a fact of life.

What is interesting is that certain systems complement each other very well, such as GPS/Loran. I have sent you a recent DoT study showing that GPS/Loran used together (not integrated, just both being present for use by the operator) increases the availability of a function—in this case non-precision approaches—*by a factor of over a hundred*. This is true in many other cases, but some GPS proponents want to use only GPS or augmented GPS to do everything for everyone. This is an approach which should be operationally unacceptable, does not meet the "prudent navigator test," and is internationally unacceptable.

Again, thanks for voicing your reservations. We need to have users being cautioned and informed of the GPS limitations, or else we are destined to have tragedies from its misuse.

**EDWARD L. MCGANN**  
*Executive Vice President*  
**Megapulse**  
**Bedford, Mass.**

*Yes, GPS errors—though typically pretty good—can get really bad. Often errors swing N and S within an hour—but they can stay stuck in one quadrant for more than an hour. So we must be careful making generalizations. But, sub-meter accuracy is becoming feasible with Differential GPS. Even good for blind landing a 747!—RAP*

**Dear Bob:**

In the Dec. 16 issue of *Electronic Design*, I noted your invitation to comment on the subject of refrigerator efficiency. Because I live in England, where we heat our house for most of the year, it is perhaps more obvious that the refrigerator is part of a larger system. In the usual domestic situation, heat given out by the refrigerator is heating the house, with the result that less heat is required from the central heating equipment. In this circumstance, the efficiency of the refrigerator is of little consequence!

**ROY WILSON**  
*Willson Associates*  
**Cheltenham, England**

*Yeah, in San Francisco, our climate's like yours, and our refrigerator's heat output is significant.—RAP*

# WHAT'S ALL THIS HASSLER STUFF, ANYHOW?

As I mentioned a couple of years ago, Bob Widlar had some colleagues who occasionally got angry with him, and started shouting at him. Poor Bob, even when he was quiet and soft-spoken—and often he really was—he just happened to say things in such a way that ticked off some people. Pierre, for one, just could not always hold his temper when talking to that *difficult* Bob Widlar. So Bob made up a “Hassler” circuit, similar to the one shown here. He put the microphone on his desk and the speaker up in the acoustic panel over his desk. Then he



*invited* Pierre Lamond, the manager of Technology at NSC, over for a visit.

Now, Pierre was immediately suspicious because Bob Widlar *never* invited him over. But he went anyway. After a while, Pierre became angry at something Widlar said, and raised his voice. A strange SQUAWK hit him in the face. When he stopped shouting, the annoying SQUAWK stopped. He tried

**BOB PEASE**  
OBTAINED A  
BSEE FROM MIT  
IN 1961 AND IS  
STAFF  
SCIENTIST AT  
NATIONAL  
SEMICONDUCT-  
OR CORP.,  
SANTA CLARA,  
CALIF.

to continue the meeting, but every time he raised his voice, the SQUAWK would assail him. Finally, he got frustrated and perplexed, and left.

Well, for the special April Fool's column, I worked as hard as I could on the circuit, and I finally got it working

on April 1. However, I'm typing this on April 1, so—surprise—now it is May as you read this, and I bet you thought I had forgotten all about an April Fool's column. (Some people thought the articles on “Robust” Design published on March 26 were just an *early* April Fool's column...) So here I bring you a circuit for a Hassler. I really wanted to plan a circuit exactly the same as Widlar used. But I could not find any record of that actual circuit. Even if I did find it, it would probably use several types of ICs no longer available. We did recreate the functional blocks, though.

**HERE'S HOW IT WORKS:** The tiny microphone should sit on your desk, aimed to pick up sounds from a visitor. The small audio signal goes through just a couple feet of twisted pair, to a preamplifier A1, and a bunch of stages of low-pass filter. We want to make sure that it responds only to audio signals below a couple kilohertz. Next comes a second amplifier A2 with adjustable gain per P1 (the output's dc level is still about 3 V dc). Then the rectified output is amplified by A3, with an adjustable offset provided by P2. A3's output is inverted by A4, and both the inverted and direct signal are fed to a voltage-controlled oscillator A5. This is set to run at 24 kHz when there's no audio signal. When loud audio is present, the frequency can come down to 14 kHz or even to 12 kHz—but no lower. The output of A5 is just fed through a couple of dumb emitter followers to drive a speaker. This provides the nasty noise you hear if someone talks too loud.

In concept, you could design this to be low powered for battery operation by turning down the amplitude of the high-frequency output when there's no significant audio input. But, realis-

tically, that's more trouble than it's worth, so you might as well use a 12-V (adjustable) line-powered supply rated at more than 100 mA. You won't use this very often, and you probably won't use it very *long*, so a simple rig with 12 V dc makes sense. One of those 12-V battery-eliminator supplies that plugs into the wall would work pretty well, too. Actually, this only draws 30 mA, per the power supply's meter, so you could run it off a few C cells or whatever you have around.

I tried to set up this circuit so it could be reproduced by the reader: I got a microphone from Radio Shack, part number 270-090, about \$1.79. I also wanted to get a cheap \$3.00 loudspeaker from them, but they don't sell those, so I bought a cheap \$1 speaker at a surplus place. However, that gave a pretty weak, wimpy output. My technician volunteered that he had an inexpensive tweeter at home, so he brought that in, and it gave a great, loud, raspy output. I went back to Radio Shack and bought an inexpensive tweeter, part number 40-1383, about \$5. And that works great, too. So you can buy one of these, or use something you have around the house. Whatever you use, it should have decent medium-loud output level. The preamplifiers (A1-A4) can be of any type. I started out with an LMC6484, a precision CMOS op-amp, but then my technician swapped in an LM837 low-noise audio amplifier, and that let me fool around with supply voltages higher than 14 V. I put in an old LM301A for A5, because without any comp cap, it's good and fast as a 24-kHz comparator. The two transistors can be any type just to provide a little current gain. The pots should be 1-turn types.

Now that I've built this circuit, I'm having all sorts of fun reactions. I don't know anybody who comes into my office to yell at me, so I had to set up situations where a guy might be tricked into starting to talk loudly, or yell. I also could turn up the gain. Or I might just leave it on the desk of an unsuspecting colleague....

This doesn't work well where the air-conditioner makes a lot of noise, or the background noise is high. If you don't have any colleagues who can be tricked into yelling or speaking loudly or get-



# MORE POWER

## Unity Power Factor Front End



for your AC to DC applications

### HARMONIC ATTENUATOR PHA1

- Universal Input (85-260 VAC)
- Power Factor .99
- Efficiency greater than 90%
- Regulated Voltage Output (365VDC)
- Use with PICO DC-DC Converters for up to 500 Watts of distributed power from 3.3-100VDC

PICO's PHA1 is the perfect match for universal AC inputs to your worldwide DC applications. Used with PICO's LPD, PD and HPD series of DC-DC converters you can obtain a variety of DC outputs from 3.3 VDC to 100 VDC in single and dual outputs. PICO systems optimize size, reliability and cost savings.

Delivery—  
stock to one week

See EEM or send direct for Free PICO Catalog.  
Call toll free **800-431-1064**  
in NY call **914-699-5514**  
FAX **914-699-5565**

**PICO Electronics, Inc.**

453 North MacQuesten Pkwy., Mt. Vernon, N. Y. 10552  
READER SERVICE 168

## PEASE PORRIDGE

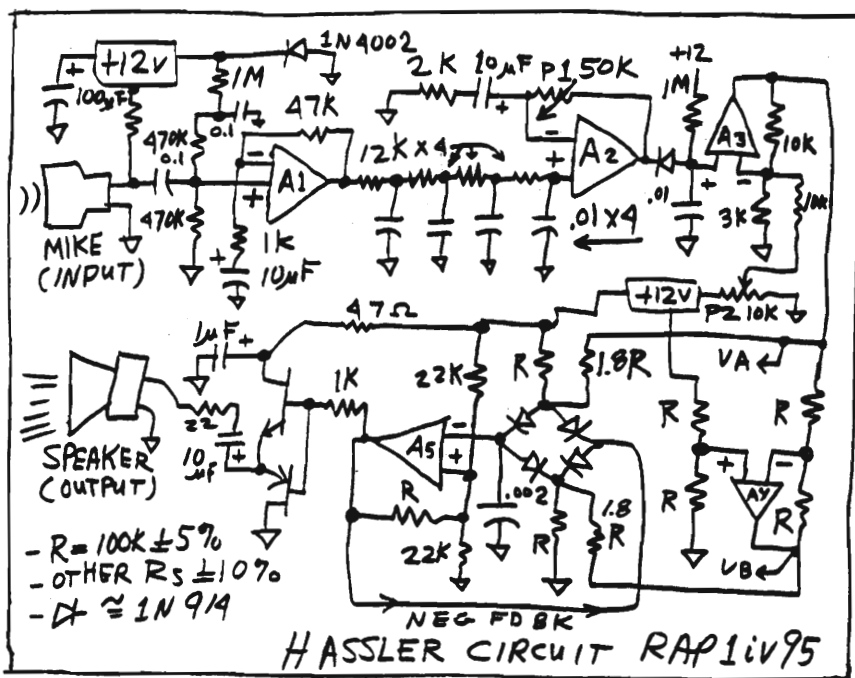

ting mad at you, it may not be worthwhile to build this. One thing I do NOT recommend is using it on your spouse—unless you're trying to get a divorce started... And you probably don't want to try this on your boss, either.

Recently, I went into our lab and yelled across the room. I heard a strange noise hassling me—the Hassler circuit was working!! Then we tried different settings of the controls (trim pots) and adjusted the power-supply voltage up and down, and found some fun areas where it seemed to work well. But, then we realized that the real trick in getting the Hassler to work was the location of the speaker. If you just put it on your desk, it becomes obvious what kind of noise is going on. So it's worth the effort to rig some long thin wires to put the speaker up in the ceiling panel, or in the lighting fixture where it's not noticeable. Or, if that's too hard, put it over in the side in a bookcase where nobody can see what's happening when they're still in the range of the microphone. In other words, I'm giving you license to play around with *psycho-acoustics*, in a perverse way. Maybe, acousto-psychics? Several people told me that we can never really replicate the Hassler, because we can't duplicate the abrasive grouchiness of Mr. Widlar. We can

never get back to where he was....

... Somebody told me the story that one evening, Widlar left the Hassler circuit turned ON. The next morning, his secretary came in and tried to type something. Every keystroke caused the Hassler to gripe at her. After a few minutes of typing, she couldn't take it. She had to go work somewhere else until Widlar came in and turned it off. Would you do that to your secretary?

I asked a few oldtimers at NSC whether that was how the Hassler worked, and they agreed that my version was not far off. One guy told me that Widlar's first attempt was to bring in the low-frequency audio using a little speaker as a microphone—which is usually a pretty good idea for a loud signal—and then to push out the high-frequency stuff through the same speaker. But he said that when they used a separate microphone and a separate speaker, it worked much better. Am I going to try this Hassler on Pierre Lamond? Well, I haven't done that yet.

All for now. / Comments invited!  
RAP / Robert A. Pease / Engineer

Address:  
Mail Stop D2597A  
National Semiconductor  
P.O. Box 58090  
Santa Clara, CA 95052-8090

## PEASE PORRIDGE



# BOB'S MAILBOX

### Dear Bob:

Within the last year or so, I became acquainted with *Electronic Design* magazine. I am concerned with the impressions I perceive from you and your readers' letters about "young engineers." In general, the "young engineer" is disrespectful and has a solitary motive, that being to outdo the older engineer. In my short career (being a mere 25 years old, I consider myself young!) I have worked with many different people, older and younger.

Many times, I found myself teaching large groups of people (mostly plant engineers, maintenance, and occasionally an interested manager or salesperson) the intricacies and operation of the robotics sold by my company. In all that time, I have NEVER been judged by my age, nor have I judged those I worked with by their age. As far as I can tell, there are only two things that determined my working relationship with these people—a desire to learn, and a desire to teach. The relationship cannot work if each person can do only one of these two things. Both people must be teacher and student.

I truly hope this gets printed and the warring factions involved realize that the only way for us to win is to fight for both sides. For when this happens, there is no dividing line, there are no sides, we are all the same, and we can move forward. We all have something to offer one another. If the knowledge that we have gained through experience or education is not passed on, it dies with us. Don't let that happen.

### TROY TROTTIER

University Of Florida

Materials Science and Engineering  
Gainesville, Fla.

*Troy, many young people have been taught to trust their computers. Now they are learning when to mistrust their computers, and I'm trying to help with the teaching. (When I was young, that was a problem we did not have.) I apologize for throwing pebbles at "young guys," but sometimes throwing*

*pebbles is a good wake-up call. I work with young engineers of all ages; I teach 'em and I learn from them. It's only when people refuse to learn that I heckle them—or did you notice? I never object to competition from other engineers, young or old. Every good engineer tries to outdo me, and that's not disrespect, but just good engineering.—RAP*

### Hi Bob:

Here's a real GPS story for you...

A few years ago, someone had the bright (for a change) idea that GPS receivers would be ideal for the trackless wastes of Antarctica, and now all the helos, most of the planes, and the Search And Rescue (SAR) team have these devices. They also are used in the relative mode for mapping, but that's not what this is about.

In December, a scientist type who didn't want to leave his buddy alone in a fish house about 30 miles out on the sea ice from McMurdo decided to jump on a snowmobile and run out there. It was a nice day, and he didn't notice how dark it was to the south. On such a nice day, you don't need a radio or a survival bag, right?

About an hour out, things went to hell, and an hour later he was missed and the SAR team called out. They inched out the flagged route he was to take, but got all the way to his destination a couple of hours later without finding man or snowmobile. One of the SAR team did notice a penguin, barely visible in the blowing snow, near the trail on the way out, and made note of the GPS coordinates. They went back to where the penguin was sighted, and nearby was their victim, huddled behind his machine in the beginning stages of hypothermia, about four hours from passing on to his reward. The storm went on for two more days.

### BILL SCHMITT

Mound, Minn.

*Even I know that polar weather can go sour rapidly. The Good Lord does*

*seem to look out for mad dogs, Englishmen, and Yanks on snowmobiles.—RAP*

### Dear Bob:

In your March 20 column on the Taguchi Method, I believe you missed the profound significance of the Taguchi voltage regulator. This circuit could make a fundamental difference for the future of humanity.

According to your calculations, the input to the voltage regulator is 138 V dc at 415 mA. The output of the regulator is 238.6 V dc at 600 mA. This means we can obtain a useful power output of 143 W with only 57 W into the regulator. That is 86 W of free energy from only a handful of specially optimized parts. Think of what we can get if we put several of these regulators in series.

I can only hope Mr. King succeeds in bringing the Taguchi Method to Ford's design engineers in the near future. Think of it—we could drive our new Ford around all day and then, at the end of the day, sell the excess gasoline we have generated back to the gas station.

### JOHN GREBENKEMPER

Saratoga, Calif.

*Soon I'll swap my old Beetle for a "Robust" Pinto. But if I neglect to go to the gas station often enough, my gas tank might overflow. Scary! Fortunately, those transistors with negative  $V \times I$  are getting cooler every second, so I'll get free air conditioning.—RAP*

### Dear Bob:

Just finished reading "The Robust Method—A New Way To Engineer" and your debunking of same in the March 20 issue.

I don't know if you're aware of the nonsense that has caused public education to devolve the way it has. But I think you've unwittingly drawn several parallels to, and demonstrated the results of, the reinventing of education. Even the vernacular fits—OBE is now "Outcomes Based Engineering!"

I really enjoy your column—critical



# MORE POWER

## Unity Power Factor Front End



for your  
**AC to DC**  
applications

### HARMONIC ATTENUATOR PHA1

- Universal Input (85-260 VAC)
- Power Factor .99
- Efficiency greater than 90%
- Regulated Voltage Output (365VDC)
- Use with PICO DC-DC Converters for up to 500 Watts of distributed power from 3.3-100VDC

PICO's PHA1 is the perfect match for universal AC inputs to your worldwide DC applications. Used with PICO's LPD, PD and HPD series of DC-DC converters you can obtain a variety of DC outputs from 3.3 VDC to 100 VDC in single and dual outputs. PICO systems optimize size, reliability and cost savings.

Delivery—  
stock to one week

See EEM or send direct  
for **Free PICO Catalog.**

Call toll free **800-431-1064**

in NY call **914-699-5514**

FAX **914-699-5565**

**PICO Electronics, Inc.**

453 North MacQuesten Pkwy., Mt. Vernon, N.Y. 10552

READER SERVICE 201

## PEASE PORRIDGE

thinking combined with good common sense. And you are correct, Sampling Theory is still valid, derivatives still work, and meters should be calibrated.

**TOM DRICKEN**

*Barton Digital*

*Cedar Rapids, Iowa*

*It's not easy to rebut all these "politically correct" arguments, whether in engineering or education. Critical Thinking is our best defense against inanity.—RAP*

**Dear Mr. Pease:**

Your recent column in the March 20 issue compelled me to write. I have thoroughly enjoyed reading each and every one of your articles, but they are starting to impact my job performance. Your stubbornness of using common sense and expecting people to produce practical examples has started wearing off on the people I work with.

For years, I was able to amaze people by bucking the "method of the day" and still produce product that met both the customer's and manufacturing's requirements. Many of my colleagues produced results using the "method of the day" without understanding how it worked, what goals it was trying to achieve, or even if the results made any sense. If the results did not meet requirements, they had no idea how to meet them.

But you've ruined all that. Colleagues now ask "all you've been using is common sense this whole time?" Now that they know the secret, and I'm afraid they'll start using it. But I will admit it is nicer to talk to people about real situations than arguing about made-up examples. Keep up the good work.

**LYNN SIMMONS**

*Austin, Texas*

*I don't know how you managed to present so many thoughtful concepts while avoiding the use of that key word: Thinking!—RAP*

All for now. / Comments invited!  
RAP / Robert A. Pease / Engineer

Address:  
Mail Stop D2597A  
National Semiconductor  
P.O. Box 58090  
Santa Clara, CA 95052-8090

ELECTRONIC DESIGN/MAY 30, 1995



**T**HE ABILITY TO STOP  
CHILD ABUSE  
IS FINALLY WITHIN OUR REACH.

Until now, there was little you could do to actually stop child abuse. But now there's an innovative new program that can actually help stop abuse before it starts. It's already producing unprecedented results. But we need your help. Call 1-800-CHILDREN today.

**THE MORE YOU HELP  
THE LESS THEY HURT.**

1-800-CHILDREN

National Committee to Prevent Child Abuse





# WHAT'S ALL THIS SECURITY STUFF, ANYHOW?

Once upon a time, I knew somebody who had a nice, new, expensive computer. Then one day it got stolen.

So shortly, he got another new computer. On this computer, he had a "Cable-Lock" restraint system installed. This was one of these cute little patches of 1/8-in. hardened aluminum, about 2 in. x 5 in., that's supposed to stick to the side of the computer by means of "technologically-advanced adhesive compounds." One day, when he wasn't paying much attention, I took my jackknife and poked the blade down between the "security plate"

and the computer. I pried and pried, slowly, and in about 3 minutes I pried the whole thing off the computer. I then looped the cable through his chair so he could tell somebody had been bugging with his "security lock." Then I re-stuck the panel back onto the computer. I added a little note: "Aren't you glad it is your friends who show that this 'security lock' junk is not worth a darn? If a



**BOB PEASE**  
OBTAINED A BSEE FROM MIT IN 1961 AND IS STAFF SCIENTIST AT NATIONAL SEMICONDUCTOR CORP., SANTA CLARA, CALIF.

thief had come by, the computer would have been long gone—again."

Well, my friend was not deliriously happy that this wonderful \$40 "security kit" was ruined. But after some reflection, he agreed that the lesson he had learned was worth more than

\$40. He figured out some new way to lock up his computer and he hasn't had any problems since.

I know some guys at work who set up the same kind of security panels and cables and "high-tech adhesives." Let me tell you, if you glue the panel down to a piece of wooden furniture, it takes a *lot less* than 4 minutes to pry the panel loose. Of course, you have to be careful not to ruin your penknife. But, that's not a big deal. After all, there's a big billboard up beside U.S. 101 in Palo Alto that says "Getting a computer for less than our prices usually involves a felony..."

One guy in another group had his computer stolen, despite the "security panels" and cables and locks. The guys in our group were concerned because they had some unique software and files, and even if they backed up everything carefully, they didn't want to have their computer stolen.

The next morning, when they came in, they found charred and smoky areas around the side of the computer, and a big hand-lettered sign draped over the front: "Joe, if the damn computer catches fire AGAIN, do not just turn off the SWITCH, pull out the PLUG from the wall, FAST/ Tom." Joe was kind of ticked off, until I explained to him that if anybody is ever going to steal a computer, they will steal *his* computer last of all. They would take ANYBODY ELSE'S computer before they took his. I mean, who would steal a computer that was about to go up in flames, *again*? So my little placard, plus some candle smoke, did solve one problem. But, it might not work for everybody.

Then one day, one of our guys got a nice new scope. I mean, a nice, 1-GHz, \$24,000 scope. I looked at it. I asked

its owner, "Would it be unreasonable for a valuable piece of portable equipment, with a handle on it and everything, to be chained down with a little more *security*?" He said, "I already asked our Security guys to put on a lock."

A day later, I dropped by to see how much "security" had been added. The Security Expert had carefully glued one of those "security pads" onto the side cover of the scope and locked it down.

Ahem. I bet every one of you guys has worked with Tektronix scopes over the years, and I bet at least 85% of you can close your eyes and SEE the hardware they use to assemble the covers of a scope. Yes, over the years, Tektronix has used—and still does use—a couple of little screws that unscrew with 1/2 turn, using any coin. A nickel works best, but in a pinch a dime or penny will do. So these security guys had carefully theft-proofed this scope—but only from a thief who did not have a penny to his name.

I looked around, and scouted out an empty office. I set a stack of old magazines in the corner. During lunchtime when nobody was around, I walked up to the scope. I closed my eyes, pulled out a nickel, and unscrewed the side cover. Then, with my eyes still closed, I carried the scope down the hallway, put it in the office, and put the stack of magazines on top and in front of it so it couldn't be seen. After lunch, all hell broke loose. The scope was gone, but the "security panel" was still there, glued securely to—the side cover. The Security guards came around and asked everybody, "Have you seen that scope?" I replied truthfully (wink), "No, I have not seen it."

After a couple of days, the scope miraculously reappeared. After I spoke quietly to its owner, we agreed that there was no point in asking the "Security" experts to try and make it theft-proof again. There was only one place to glue the security panel that would make it hard to steal—on the face of the CRT. And if they did that, we could not read the display, and we could not use the scope, which would surely be ruined. So we went inside

## PEASE PORRIDGE

the back and bolted a hasp onto the frame, and bugged the threads on the bolts, and epoxied over the bolt ends, and put on enough of a medium-heavy chain to keep honest people honest. So far, the scope hasn't gone for a walk....again.

But I was ticked off. I wrote a nice letter to the President of Tektronix, (and a copy to the head of Hewlett-Packard instruments, too). I pointed out that no physical lock or cable would really keep any serious thief from walking off with a valuable scope. I mean, there are bicycle thieves who walk around with a Dewar flask of liquid nitrogen. If they want a bicycle, they soak the lock in liquid nitrogen, then whack it with a hammer, and the steel shatters—even the best alloy steel locks. So, locks and cables alone will not keep crooks away.

I read in the Owner's Manual of an Oldsmobile I had rented that if a thief disconnects the radio from +12 V power, he can't run the radio again because you need a password to reactivate it. So, eventually, if car-radio thieves learn enough, they will learn to go steal *someone else's* radio.

Now, every modern scope has a computer. And every computer has a few bits of memory left over. So, it would be easy for the designer of a scope, or an expensive Spectrum Analyzer, or similar instruments, to build in as much security—*REAL* security—as desired. One option is to put in your password every day, or it won't play. Another option is that if it's unplugged from line power, you have to insert your password before it will play. Or the user can select from, perhaps, any number of other options. Still, this kind of strong computerized security would be very inexpensive—yet be of good value.

Of course, the scope would have to be protected by a colorful label, explaining that it's protected by (Special Trademark) RAP's Security computer program, so don't bother to steal it because it won't work without its password. Without that sticker, some dumb guy might steal it, and when he realized he couldn't get it to work, he might just chuck it in a river, or off a roof, out of frustra-

tion. So, you have to have this security well-publicized to protect you from *stupid* thieves.

Now, providing real security for computers should be even simpler. Every computer has soft disks and hard disks, so you can insert a little program. Not just a trivial program, but a hard-to-beat security program. With *not just* any trivial password, like your kid's middle name, or your birthday, but a code that's a little more difficult to pick. It also must have procedures so if you punch in the wrong password three times, you gotta wait 10 minutes to try again.

This will basically put the kibosh on crooks that like to try a list of 1000 possible passwords, real fast. Yes, they could try a bunch of passwords, but as soon as they're reminded that it will take them HOURS, they will go elsewhere. Then the program must be installed in such a way that you can't go in and disable it. Like the one-way screws in bathroom fixtures—although I don't know anyone who wants to steal toilet stalls....

Again, you will need to decorate your computer with a DECAL or STICKER to point out that if you steal that computer, it's worthless because it can't be used. That sticker must be very securely mounted, because if the thief just tears it off, he may be able to sell the computer to some guy who doesn't know any better. Maybe a painted or stenciled logo, so the scope is INDELIBLY, PERMANENTLY marked. You get the idea.

Well, I haven't yet done any computer searches, but I've never heard of any security program that includes all of these essential elements. Maybe a password, but not the sticker. So, if anybody wants to take a license to make and sell this kind of security software, you can write to me, and I'll be very happy to sell you an inexpensive license to use any of these ideas on your scopes or your computers or instruments.

When I did complain to the heads at Tektronix and HP about their unhelpful attitudes on *security*, six years ago, I did NOT tell them all the details of how to improve security. So maybe my new patent will be quite strong, and

valuable for me, and useful to *you*.

All for now. / Comments invited!  
RAP / Robert A. Pease / Engineer

Address:  
Mail Stop D2597A  
National Semiconductor  
P.O. Box 58090  
Santa Clara, CA 95052-8090

P.S. For all of you guys who do have those absurd stick-on "security panels": Putting a bead of epoxy all the way around the periphery of the plate, so I can't get my pen-knife in there, will provide a considerable improvement in the degree of security you have. A determined guy with a hammer and chisel can still get the panel off, but most thieves like to work quietly and quickly. Most of them don't bring a blowtorch. So you may be able to deter a thief and keep honest people honest—at least, a *little bit* honest.

P.P.S. I talked to some guys who are knowledgeable about computers, one MAC guy and one IBM PC expert. They told me the same basic story, that no ordinary software program can provide security against a smart, determined thief. If the guy unplugs the power and turns off the internal-clock battery, he can always fool the thing into starting up with an external hard drive, and all internal security programs can be bypassed. The only guy who had any chance against a determined thief programmed a PLA (Programmed Logic Array), which was hardwired into his main processor board. Even if you knew exactly what he had done, you couldn't outwit the code he had programmed in. Barring that, who can tell me that they know a way to make a PC theft-proof? Tell me who advertises such a program, so we can all have a good laugh.

One nervous person asked me to be sure and mention that not all of these security problems are at NSC. I replied that if there's any company where no theft occurs, it must be a very small, closely-held company. Even police stations have problems with items "disappearing." Hardly anybody is immune....sigh.



# BOB'S MAILBOX

## Good morning Bob:

I drove a buddy to the post office the other day. When he came back he said, "They weren't very efficient. I had to wait a long time. There was just one window open." Of course he (like others) had said efficiency when he meant responsiveness. Being naturally argumentative, I pointed out that keeping only one window open was probably efficient for them, and he, on the other hand was inefficient for standing in that long line. That started me thinking about the trade-off between efficiency and responsiveness. Responsiveness is usually bought by having extra (mostly unused) capacity. This is opposed to efficiency, which calls for laying off extra capacity. The formula is crudely approximate to:

$$(e)(r) = k$$

where  $e$  = efficiency,  $r$  = responsiveness, and  $k$  = constant. We'll just measure  $e$  and  $r$  in a way that makes this equation work.

Laugh if you will, but the Postal Department is a model of efficiency (useful work per dollar). It's a miracle that for 32 cents I can put a letter in a box at my house, and a few days later (usually 2) that letter will appear in your mailbox. I can put hundreds of letters in the box and they will all go where they should. I've never had a letter that I mailed get lost, and as far as I know, I've never had a letter mailed to me that got lost (although one got burned a little once). They are not very responsive.

On the other hand, let's look at the emergency medical service. Here, there is a lot of usually unused capacity. Ambulance drivers and highly trained EMS technicians are just sitting around waiting for an emergency. But, boy can they be responsive when you need them. Efficient they are not. Just look how much a ride with them costs. If you want efficiency, call a taxi. You may wait 45 minutes, but it is much cheaper than an ambulance.

A factory, like mine, has the same trade-off. You can be efficient by only

making a few things in a continuous flow process, and keeping raw-materials inventory low. That's the way to make tape. Or, you may be responsive by making short runs of lots of things and keeping lots of parts in inventory to build units on short notice. You need to know which business you are in.

Then there is flexibility. Flexibility helps make  $k$  in the formula larger. For example, here in Austin, when you need an ambulance, they usually dispatch an ambulance and a firetruck, because the firetrucks are more widely dispersed and are likely to be nearer...

I've seen it work. I was at my father-in-law's house once when he suffered an allergic reaction that caused his throat to constrict. In less than 3 minutes after we hung up the phone, the firetruck was outside with oxygen. They must have started rolling before we finished the phone call. The ambulance was there about 8 minutes later with adrenalin (which they did not use) and about 8 minutes after that, a full-fledged emergency-trained doctor was on the scene.

**ROY McCAMMON**

### 3M/Test and Measurement

Austin, Texas

*In our business, we're trying to be (a) more efficient and (b) faster on delivery—and it ain't easy. We're investing a lot of effort to improve "a" without hurting "b" and vice versa.—RAP*

### Dear Mr. Pease:

One of the great problems I face as an independent consultant is Design Quality. It is something that American management generally does not understand. From reading your columns and articles, I am sure that Design Quality is something you understand and I think it has been responsible for much of the success of National's Linear products. A lot of managers, when faced with the cost of solving a problem the right way, with Design Quality, will opt for a path that looks less expensive by hiring a person or company at a much lower cost. The result is, at best, a product without Design

Quality. At worst, the result is six months and \$50,000 wasted. A product without Design Quality costs money every time the product ships, and no amount of "continuous improvement" can achieve Design Quality.

Design Quality needs to be differentiated from Process Quality. Process Quality is what most people think about when they talk about quality. It is Statistical Process Control and Quality Circles and Continuous Improvement and all that stuff that Deming and others have promoted, and that National uses every day. And it works very well to control production processes. It can not be applied to Design Quality because the concepts are completely different. Continuous Improvement is an attempt by the Process Quality people to evolve a design into a Quality design. This is not possible using quality techniques such as the Taguchi methodology. Continuous Improvement usually becomes an attempt to make a silk purse out of a sow's ear. You can probably make a nice purse, but it will not be made out of silk. Continuous Improvement can make a design better, but only up to a point.

Design Quality is something that comes from a designer's head. It requires large amounts of Native Signal Processing capacity (intelligence) and a massive database of tools, techniques, component data, process information, tricks, circuits, etc. The book "Analog Circuit Design" (Jim Williams, Ed.), which you contributed to, is actually a very good description of the requirements for Design Quality, although the description is spread among at least half a dozen of the articles. Interestingly, the same requirements are applicable to digital design, software design, mechanical design, and all other design areas. Design Quality requires thought, and lots of it, and a deep understanding of the design and production processes and the application requirements. A product with Design Quality has no problems in production, is easy for the user to apply, and does what is expected with unex-



U  
N  
P  
L  
U  
G  
G  
E  
D

nvSRAM



### Memory: Saved by Simtek

- Broadest line of monolithic nvSRAM products
- Select from 4K, 16K, 64K and 256K densities
- Unlimited and fast (to 25ns) read/write access to SRAM
- Commercial, industrial and military (SMD) versions
- Multiple surface-mount and DIP package options
- 10-year data retention guaranteed —  
over full temperature range
- Minimum 100,000 store cycles

800-637-1667 or 719-531-9444, fax 719-531-9481  
1465 Kelly Johnson Blvd., Colorado Springs, CO 80920  
Internet web site: <http://www.csn.net/simtek>



READER SERVICE 180

## PEASE PORRIDGE

pected inputs. It has conceptual integrity and it simply works.

As noted above, most managers do not understand the impact of Design Quality on their company as a whole. They generally choose the option with the lowest up-front cost rather than the lowest cost over the lifetime of the product. Ken Blemel of Management Sciences Inc. stated it rather succinctly as follows:

$$\text{Design objective} = \text{MIN} \int_0^{\infty} \$ dt$$

In words, this means that the objective of the design process is to minimize the total dollars spent over the lifetime of the product. This includes the design cost, the manufacturing cost, the product-support cost, the disposal cost, and the liability cost. Design Quality does this. Minimizing the design cost will generally drive up the cost of everything else.

My area of expertise is power-supply design, and it is one of the most difficult tasks in analog electronics to do well. Doing it well requires a deep understanding of a broad range of subjects, and it takes about 10 years to become a proficient designer. Most managers are not aware of this and therefore opt to minimize the design cost rather than the lifetime cost. They have no clue that Design Quality requires thought and experience and that this costs money up front. They become penny wise and pound (£) foolish.

**PHILIP C. TODD, P.E.**

**Power Innovations  
Long Beach, Calif.**

*Good design has always been non-trivial—and still is for new reasons. Good checklists are necessary but not sufficient. Computers may help, but then they can be part of the problem. Twice a year, at best, I have to override my computers when they start lying to me. That's my most important job. Same for you?—RAP*

All for now. / Comments invited!  
RAP / Robert A. Pease / Engineer

Address:  
Mail Stop D2597A  
National Semiconductor  
P.O. Box 58090  
Santa Clara, CA 95052-8090

# WHAT'S ALL THIS P-I-D Stuff, ANYHOW?

Recently, I wrote about refrigerators,<sup>1</sup> pointing out that there are several ways to control a servo loop, such as a temperature chamber, or an oven, or a refrigerator using thermoelectric coolers (let's leave bang-bang controllers and on-off heat-movers out of this). Fuzzy Logic controllers can work pretty well, and so can a P-I-D (or PID) controller. That's pronounced "pee-eye-dee", not "pid". Several readers said that they were not very knowledgeable about PID controllers. They don't teach very much about them in schools these days, I guess. They asked me, "Please show us a good example of a PID controller." Well, I agree completely that an example is one of the most powerful tools. I'll show you a couple of examples, so you can see how easy it is to come up with one yourself. And I will point out that, after a Fuzzy Logic expert showed us his best example of a nice simple F.L. controller, I had no idea how to make it myself. Do you know how to run a F.L. controller after seeing an example of one? I don't. I hope that would not be true for my examples.

One example is found in my book on Troubleshooting,<sup>2</sup> where I had to control the temperature of a blast of heated air. When you apply more watts to the heater, there's a delay before the sensor warms up to its new temperature. In fact, there are and . This is a fairly interesting kind of system for closing the loop accurately, but not really difficult. Engineers have known how to do this for many years—about 140 years, I would say. Back in the 1880s, when most servo loops were mechanical or pneumatic, and the instrumentation was crude, it was a wise person who understood how to close a loop with good accuracy and loop stability. But for the last 40 years, when a good operational amplifier costs \$22 or even less, it's been a piece of cake.

Note, a wise old colleague observed that the introduction of the Integral term to Control Theory is credited to the 1930s. But I found good documentation in my Encyclopedia Britannica<sup>3</sup> that a flyball governor with an integral term was invented by Sir W. Siemens in 1853.<sup>4</sup> Never bet that the British didn't get there first. However, I can't say that I've seen the Derivative effect exploited in that 1894 Encyclopedia. So maybe the PID controller is only about 60 years old...



**BOB PEASE**  
OBTAINED A  
BSEE FROM MIT  
IN 1961 AND IS  
STAFF SCIENTIST  
AT NATIONAL  
SEMICONDUCTOR  
CORP.,  
SANTA CLARA,  
CALIF.

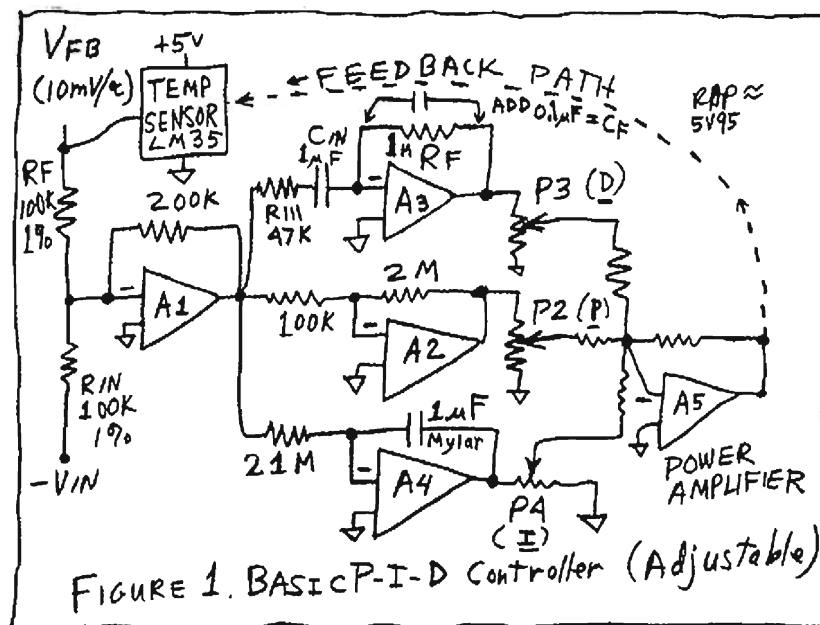

# PEASE PORRIDGE

First of all, let's discuss the nomenclature—"PID." That stands for  $P$ ,  $I$ , and  $D$ . You can build some controllers using only  $P$  and  $I$ , and others using only  $P$  and  $D$ , but when you need good performance, using all three terms can provide REAL advantages. Let's see how these terms are made, and how they are used.

First, these functions are used to operate on the the difference between the feedback parameter and the desired parameter. Let's spell out an example. Say that we want to define a precision heater controller—perhaps for an electric frying pan—with a sensor for the controlled chamber that puts out  $10\text{mV}/^\circ\text{C}$ . The input command is  $-350\text{mV}$  (which corresponds to a desired temperature or "set point" of  $+35^\circ\text{C}$ ), the output of the temperature sensor is  $+250\text{mV}$  (which corresponds to a temperature of  $25^\circ\text{C}$ ), and the load must be heated to get the feedback voltage to track (equal but with opposite sign). What's needed, then, is a circuit to operate on the error, namely  $(V_{\text{out}} + V_{\text{in}})$ , or  $-0.1\text{V}$ . Op amp A1 does just that (). (Let's keep things simple by considering primarily linear systems; if the system actually has some nonlinearities, we can address them later.)

After we generate that error term, you will want to generate a correction signal that's a function of the Error Signal. As I discussed back in December, you might design your system so that a heater has its watts linearly Proportional to the temperature error. "If chamber temperature is very cold, turn heat up high" is how the Fuzzy Logic guys like to say this. This is partly wise, because if the temperature really is too cold, turning on the heat is one of the good things to do. That is the term.

Referring to Figure 1, we follow the error-detector amplifier A1 with a Proportional amplifier A2. We can control the gain of the Proportional path by adjusting the pot P2 at its output, so as to get the right gain going to the power amplifier, A5. Eventually, we will figure out what to do with A3 and A4, but right now we can set their trim pots to ZERO, and then they're out of the picture. Let's keep things simple, one step at a time.

Now, let's say you pour a bucket of very cold water into the electric frying pan, where the controller is set for  $+35^\circ\text{C}$ . The sensor soon says it's much too cold, so the heater turns on pretty hard. As the temperature of the sensor gets near the desired temperature—the —the heater will eventually be turned off. The problem is that any heater has a delay before its heat gets to the chamber and load and sensor. So, when the error gets to zero, and you turn off power to the heater, the chamber still keeps on heating for a while and overshoot occurs. If you turn the gain down low, this overshoot may be minor. But if you decide that you must have very high accuracy and turn up the gain, overshoot is certain, and oscillation or bad ringing is likely.

Now, how can we avoid this overshoot by foreseeing this situation and recognizing that the power needs to be shut down a little early? The best solution is to add in A3 to compute the Derivative of the temperature error—the rate of change—while the proportional amplifier is computing when the error becomes small. When these two signals are combined properly, the Derivative signal lets the controller decide, "Whoa, we are getting very close to the set point, the sensor's temperature is still rising pretty rapidly—time to cut back on the power." In practice, this works quite well. This is called P-D control, using just A2 and A3 for the Proportional and Derivative terms. You trim P3 to the setting that gives good results—not too much overshoot (not enough derivative) and not too slow (too much derivative term). The Fuzzy Logic guys achieve this same function by using the words: "If the temperature error is small (negative) and the rate-of-change is small (positive), heating power should be small." This works, too.

In theory, you can make a differentiator—a rate-of-change computer—by taking op amp A3 and just connecting an input capacitor  $C_{\text{in}}$  and a feedback resistor  $R_{\text{f}}$ . But in practice, with real op-amps, this will cause a local oscillation of the amplifier, due to the lag in the feedback loop. The fix is fairly simple—for most cases, to prevent local oscillations, add a small resistor  $R_{111}$  in series with  $C_{\text{in}}$ , and add a small capacitor ( $C_{\text{f}}$ ) in parallel with  $R_{\text{f}}$ . In practice, if you make  $R_{111}$  about  $1/10$  or  $1/100$  of  $R_{\text{f}}$ , and  $C_{\text{f}}$  about  $1/20$  or  $1/200$  of  $C_{\text{in}}$ , that works pretty well. In other cases, it may be a bit more critical which value you choose, either to prevent local oscillation or avoid degradation of loop stability.

The P-D controller is quite good for many servo control applications. To a large extent, many Fuzzy Logic ontrrollers are quite analogous to a P-D loop, and often they work well. NOW let me invent a case where the P-D controller (and the simple F.L. controller begins to work (that's a technical term). Let's take this  $+35^\circ\text{C}$  controller outside on a cold day. The water stays warm for a while, but the air starts to cool it off. After a while, the Proportional path turns up the heater. But there's still an error—an error. If the fry-pan needs  $50\text{W}$  to keep the water at about  $35^\circ\text{C}$ , then the error will be  $50\text{W}$  divided by the gain.



# PEASE PORRIDGE

To avoid a large error, it's natural to just turn up the gain—which is what some people propose to do. But when you turn up the gain, the loop stability is hurt. How badly? Ahhhh that is hard to predict—hard to model. The reason is that the thermal transfer from the heater to the water and the sensor isn't a simple model. It's not a simple lag. The transfer might be similar to a cascade of 5 or 10 lags, so that a step of heat causes a slow change of the sensor temperature. It's to do this in a computer—or within SPICE—but it's not really easy. Furthermore, you basically have to measure some real response of the system. You can guess, but it's not really easy. Anyhow, if you take enough data and generate an accurate-enough model, you can show that you can turn up the Proportional Gain a certain amount. But, if you go any higher your loop will oscillate, or ring severely. Let's say that you can only set the Proportional gain as high as  $50 \text{ W}/5^\circ \text{ C}$ , without oscillation. Your need is for less than  $1^\circ \text{ C}$  of error. But there remains about  $5^\circ$ .

FIRSTLY, you might add as much insulation as you can to cut down the amounts of watts needed. But let's say there is still more than  $2^\circ$  of error. What can we do?

One alternative (secondly) is to sense the outside temperature. We could then use that to that 20 or 40 W of power will be needed. We could add that information into the controller—which does work at times, sometimes very well. This is known as .

Another thing we could do (thirdly) is add not just extra insulation, but a heated shell around the experiment—perhaps at  $30^\circ \text{ C}$ . That could greatly improve the accuracy, but often this amount of complexity is unacceptable.

Okay, the fourth option—and a fairly popular and inexpensive one—is to look at that error signal (the output of A1), and if there's any dc error, just INTEGRATE that signal using A4. Then feed that output through its adjustment pot (P4) and sum it with the other signals. This beats the conundrum: to get full accuracy in view of the rule, "You can only turn on the heat high when the error signal is large." In this case, you can turn on the heat high even if the error signal is NOT large—but you may have to wait a while for the integrator to do its job. Why not just turn up the GAIN for the Integrator? You can do that to some extent. If you overdo it, that makes the loop unstable. So don't overdo it.

The best thing about using the Integrator is that it lets you turn down the gain of the Proportional amplifier. If you turned up the Proportional gain too high to try to cut down the error, that will cause instability as I mentioned earlier. When you have the integrator working, you can turn down the Proportional Gain and improve the loop stability a LOT, yet still have infinite gain at dc. You can have ZERO static error.

But, don't turn the Proportional Gain down TOO FAR. If you did that, the I and D terms would act like an L-C filter with no damping. So if you turn P2 down to zero, that's sure to cause oscillation, too. Now that you have the Integral path working, the gain setting for the Proportional term acts as a DAMPING FACTOR to prevent the loop from ringing. As you can imagine, the optimization of such a loop isn't trivial. Also, in many cases, these loops may be slow, so it's hard to see if any changes you're making are doing more good than harm.

Hint 1: Use a slow strip-chart recorder so that you can see the shape of the loop's step response, and if you're making any improvements. Or use a storage scope. Or a Rustrak meter.

Hint 2: Take a little open-loop data to show the delay from a step of heat to a change of output temperature. Build up a cascaded R-C network to stimulate that slow lag (Fig. 2). Then change the lag's response by a factor of 100 by decreasing all of the capacitors by a factor of 100. design your controller to make that loop stable at a speed that's easy to observe. Then scale that controller 100:1 slower, and you're fairly close to having a controller that will work. This is one form of Analog Computer.

Hint 3: If the system changes—if the amount of water in the fry-pan decreases—you will probably need to change the coefficients of your system. You could turn those pots, or you could use multiplying DACs in place of P2, P3, and P4, to get the coefficients you want. Not trivial—because the system won't do it for you—you have to tell it what you want. But this IS feasible.

## PEASE PORRIDGE

Hint 4: This circuit won't work well at all with general-purpose op amps. An LM741 at A3 or A4 would cause HORRIBLE errors, because the resistors in the differentiator and in the integrator will be quite high—perhaps 2 or 5 megohms—forcing you to get op amps with low bias currents. But, fortunately, good op amps with low input current (50 pA or 0.05 pA) aren't expensive these days.

Hint 5: When you have all of this worked out and optimized pretty well, you can do the whole thing with one op amp—you may not need five amplifiers. In Figure 3, op amp A6 does the whole thing. Of course, you don't have the flexibility of three independent controls, but in many cases you don't need that. In this case, the output of A6 is a summation of the Derivative and the Integral terms, with a Proportional (damping factor) term also included.

Can Fuzzy Logic likewise take advantage of an Integrator to convert from PD to PID? Yes, and pretty easily, if you figure out the right trick. Of course, if the system is REALLY nonlinear, or a nonlinear controller is really needed, then nothing is simple, and you might have to write 125 or 343 rules. Still, a small Integral term could let you effectively turn down the "gain" of the Proportional path and greatly improve the dc accuracy AND the loop stability. Of course, this doesn't mean that you can easily get fast settling under difficult conditions, such as "we have no idea how much water is in the pan." But there's still a definite opportunity for improvement by adding in the integrator<sup>5</sup>.

As I mentioned in '93, F.L. does not, by itself, compute a derivative. So if you want a derivative term, you have to generate a derivative and digitize it, then present it to the F.L. controller: OR, you digitize the proportional signal and take a DIFFERENCE every few seconds, then present THAT as a derivative signal to the F.L. controller: So, in exactly the same way, the F.L. controller can't generate an integral. But, you can program a subroutine to compute the integral of the Error Signal and present it to the F.L. OR, you could compute the Integral term and just ADD it to the Proportional term, and then process that total without any fanfare. If the system is fairly linear, nobody will ever know that you cheated, and it will probably work perfectly. You may not have to write 343 rules—maybe 25 or 49 will work just fine!

So, if you have a few bucks worth of op amps and a little time, you can make a pretty darned good controller: Much better than a bang-bang controller. When I came to NSC back in '76, I found several Application Notes where we had recommended a temperature controller. But either the controller had finite gain (i.e., poor gain) or else ran bang-bang, with various kinds of noise and inaccuracy—and bad error!! In my App notes, I recommend that a proportional controller with stability enhanced by the PID terms, can be fairly simple and effective.

OF COURSE, if the delay from the heat to the sensor is that makes everything much harder. Locating the sensor where it gets a prompt response to the heat can help a lot. Also, you may get better results from having two sensors. The one that drives the Differentiator may be located very close to the heater as an aid to stability. But the one that drives the integrator may live in the "sweet spot"—the exact place where highest precision is needed. If there's an extra lag there, that will certainly make the loop difficult to engineer.

Then the other tricks mentioned above—the feedforward path and the oven-within-the-oven—may be justifiable. In all of the cases where transport delays occur, system design can be very challenging. But it needn't be considered impossible or even very difficult. And it's usually not a situation where Fuzzy Logic has any inherent advantages. In fact, PID usually has advantages over a Fuzzy Logic controller if that controller tries to do without any Integral term.

Comments invited!/RAP  
Robert A. Pease/Engineer

# WHAT'S ALL THIS SUMMER FLOOBYDUST, ANYHOW?

**W**ell, finally I have gotten enough good material to put together this column of "Floobydust" or, in other words, "Miscellaneous."

• One guy faxed me some info on JFETs. He found some Hitachi FETs, 2SK1070s, with just 18.8 mV per octave of  $I_{ds}$ , when operated at a small (sub-threshold) bias. These are some of the hot FETs that have very high  $g_m$  running at high currents, as well as low noise. That's not *exactly* 18 mV per octave, but it's pretty close!

Also, I received a number of articles sent by Dr. Michael Alles of Ibis



**BOB PEASE**  
OBTAINED A  
BSEE FROM MIT  
IN 1961 AND IS  
STAFF  
SCIENTIST AT  
NATIONAL  
SEMICONDUCT-  
OR CORP.,  
SANTA CLARA,  
CALIF.

Technology Corp., 32A Cherry Hill Dr., Danvers, MA 01923. He pointed out that while ordinary MOSFETs have fairly good  $g_m$  (perhaps 27 mV per octave), if the current density is rather low and the gate oxide is very thin, you can get even *better*  $g_m$  per mA with SOI (Silicon On Insulator) FETs. Some of those examples<sup>1,2,3</sup> indicate that up to 18 mV per octave is possible. So if you need a FET to give really excellent  $g_m$  per mA, the

SOI guys may be able to provide it. Now we have a pretty good understanding of why MOSFETs' rate of change of current is usually worse than 18 mV per octave. (This corresponds to the case of  $g_m/i_d$  falling be-

low 38.6 at room temp.) Unfortunately, we have yet to see an explanation of why the  $g_m/i_d$  of a JFET falls below 38.6, by any particular extent, as a predictable function of any doping or geometrical considerations.

• I did get magazine articles and clippings from several guys about the "Spacistor," invented in 1957 by Raytheon. The best info came from Mr. Burch of Austin, Texas, who sent in a clipping from the Sept. 1957 *Electronic Industries & Teletech* magazine.

The Spacistor was NOT a FET. It was a single p-n diode, with a reverse bias, and with two point contacts made into the space-charge region. One of the points was supposed to inject carriers into the region, and the other contact was supposed to modulate the current flow with high bandwidth. When you think about it, it was NOT going to be easy to drop two little contacts into the narrow space-charge region. The Spacistor never had a chance, competing with modern planar transistors and ICs. Raytheon never broke even on that project.

• I got a neat, simple letter from Dennis Feucht of Townville, Pa. He sent me a simple sketch of a dead zone's characteristics compared to a hysteresis curve, and the statement "dead zone  $\neq$  hysteresis."

I got in touch with Dennis, and we debated this. I admitted I was perhaps guilty of a little sloppy thinking, but not too far out. A dead zone is just a nonlinear transfer curve that has no memory, no energy storage. A hysteresis curve typically consists of a dead zone *plus* some energy storage (an inductor or a capacitor) or perhaps a mechanical position error. So while a dead zone is *not* identical or equal to

a hysteresis curve, it can be fairly closely related—it can be made from one. Thanks for requiring me to clarify this, Dennis.

• Recently, I got an anonymous letter from "a Fellow Engineer" who thinks that I have wasted 2.9 years of my life driving  $10^6$  miles in my VWs. "Oh, I'm sure you think about work while you're driving, but if you do, you are probably endangering your life and the lives of your fellow commuters." How does he know that? Over those  $10^6$  miles I've proven that I can think and drive safely at the same time. But, that doesn't mean I'm not *thinking* some terrifying, mean, nasty, dangerous thoughts.

"I can't think of a more wasteful/inefficient way for a brilliant and inciteful (now *that's* a Freudian slip!—RAP) person like yourself to waste your life." Well, if Mr. Fellow Engineer had been thoughtful enough to include his address, I would have asked him how many hours a week he spends watching TV. That's a pretty wasteful/inefficient way to spend your life, in my opinion. Besides, the pictures are better on radio, as those of us who commute will agree.

"I can't help but feel sorry for you Bob, as well as others who are trapping themselves in the habit of long-distance commuting." Well, I *like* to live in San Francisco, and I *like* to work in Silicon Valley. I can't help but feel sorry for people who insist on a short commute, and are *trapping themselves* into living close to where they work, or working close to where they live.

I can live where I prefer, and commute to the place where I like to work. My commute time is within a couple minutes of what it was 15 years ago. Sometimes more, sometimes less. I know people who commute 8 miles and spend almost as much time as I do poking along in stop-and-go traffic. That's not my idea of fun.

It's also true that I *like* to drive, and I like to ride while my wife or sons drive. Sometimes we drive a lot on vacations. Maybe Mr. Fellow Engineer does not. Since he left no address, I can't ask him how many



# Accessories for rf testing

**PCB emissions scanner** • Locates low-to-high emissions, displays color image, stores data for design corrections at development stage.

**Dual-directional couplers** • Seven models up to 15 kW, matched to AR amplifiers and antennas.

**Ultra-broadband E-field monitor** • Four-channel capability, 1 to 300 V/m, isotropic probes cover 10 kHz to 1000 MHz or 80 MHz to 40 GHz.

**Broadband fiberoptic data links** • Modular plug-in analog systems for acquiring and measuring interference data, stimulating EUT, displaying results in color or monochrome, 10 kHz to 1 GHz.

**Fiberoptic CCTV systems** • Watch performance of EUT under hostile EMI and/or EMP shielded-room conditions, in color or monochrome.

**TEM cells** • Half again the bandwidth of comparable-size chambers: To 750 MHz for 15-cm EUT, 375 MHz for 30-cm EUT.

**Computer bus interfaces** • Two models, for isolated GPIB connection or isolated TTL connection, permit remote operation of amplifiers.

**RF connection kit** • Things you'd search for around the lab: Cables, coax adapters, connectors, fuses, lamps, fabricated cables.

**Power combiner/dividers** • Combine signals from four amplifiers, or divide one signal into four outputs.

**High-power rf matching transformers** • Match 50-ohm input to 12.5- or 200-ohm output. Up to 2 kW cw.

Call toll-free (1-800-933-8181), and one of our applications engineers will answer the phone.



160 School House Road,  
Souderton, PA 18964-9990 USA • Fax 215-723-5688  
In Europe, call EMV: Munich, 89-612-8054;  
London, 908-566-556; Paris, 1-64-61-63-29. 6312

READER SERVICE 83

## PEASE PORRIDGE

miles per year he drives.

• Another writer asked, "You propose it's a good idea to practice double-clutching your shifts, so you will be able to shift without the clutch when your clutch-cable breaks. But if you did not double-clutch, perhaps the cable would last twice as long?" Good question! Actually, the cable's life seems to tolerate an almost infinite number of shifts while it is new and well-lubricated, but when the grease wears off and it gets a little rusty, it appears to wear rapidly. So if I didn't double-clutch, the cable would *not* last much longer

• I also would like to comment on a related topic: I pay extra for my auto insurance because I drive a lot of miles, which I think is absurd because I've had VERY FEW accidents in 40 years of driving. It's well known that people who drive few miles have more accidents per mile. People who drive a lot of miles are better drivers and have fewer accidents per mile. So why do the insurance companies rip us off? Because they can....

• While we are on the topic of cars, I want to mention a neat machine described in a data sheet sent to me by Professor C. Zardini of the University of Bordeaux, France. It is a hybrid car (gasoline-electric with NiCd batteries) made by Irmscher of Germany<sup>4</sup>. The good news is that its little 0.09-liter engine can put out 9.5 hp and only needs to run 1/3 of the time. The gas mileage is about 140 mpg. The batteries, about 770 lb. of NiCds, can store 40 Ah at 390 V, which is enough to provide a range of about 70 or 80 miles at 48 mph without starting the little engine. Now, that's a very efficient car, since few cars can run on 3 hp at cruising speed.

Now, the not-so-good news: *First* you have to pay \$24,000 for the car. *Then* you have to lease the batteries at \$3.50 per day. In Europe, where gas costs \$3 or \$4 per gallon, this is not a big winner. But it may save you a little money if you drive many miles per day, so that the \$3.50 per day of battery rental is spread over a lot of usage. With the specs given, the car won't be very cost-effective here in the States, where gas is cheap. But it does indicate the feasibility of a high-

tech hybrid car with a small engine. Maybe in a few years, a car like this will be affordable.

But, come to think of it, let's say this car makes economic sense only if you drive more than 40 or 50 miles per day. That makes sense only if you get on an Autobahn. And the cars on the Autobahns cruise at 70 mph, minimum. I wonder if this little 9-hp car can keep from being overrun by faster VW Beetles out on the Autobahn? I don't think it can make 140 mpg at 80 mph.

It also states that the little engine, whirring along at a constant 9000 rpm, is only rated to run 500 hours, or about 60,000 miles, before it should be replaced. Maybe you get some good specs from running a 90-cc engine at 9000 rpm, but in the long run, a little 0.16-liter engine at 6000 or 7000 rpm might live longer and be more economical. Note, the 9000 rpm is a constant speed, making for optimum emissions and efficiency and the simplest energy transfer from the alternator into the batteries. That sounds like some pretty good sharp-pencil engineering!! Now if they can just figure out how to build and sell it for \$12,000....

All for now. / Comments invited!  
RAP / Robert A. Pease / Engineer

Address:  
Mail Stop D2597A  
National Semiconductor  
P.O. Box 58090  
Santa Clara, CA 95052-8090

References:

1. S. Parke, C. Hu, and P. Ko, "Bipolar-FET Hybrid-Mode Operation of Quarter-Micrometer SOI MOSFETs," *IEEE Electron Device Letters*, May 1993, pp. 234-236.
2. J. Colinge et al., "Silicon-on-Insulator 'Gate-All-Around Device,'" *IEDM '90*, p. 25.4.1-25.4.4.
3. K. Suzuki et al., "Scaling Theory for Double-Gate SOI MOSFETs," *IEEE Transactions on Electron Devices*, Dec. 1993, pp. 2326-2329.
4. Irmscher Automobilbau GmbH, Bahnhofstrasse 79, D-73630 Remshalden-Grunbach, Germany; phone: 00-49-7151/9 71-0.

## PEASE PORRIDGE



# BOB'S MAILBOX

### Dear Bob:

Last year, in your Hoax column, you wrote about some of the claims made for high-end audio equipment, such as speaker cables. I never realized how serious these "High-End Audiophiles" were until I picked up a recent audiophile catalog. It seems like more space and more superlatives are devoted to pieces of wire than any other component. They also have some of the highest prices. You can spend more money on one pair of speaker cables than most people might spend on an entire stereo system!

In addition to every combination of solid wire, Litz wire, and flat wire, now there are Water Cables. The water-filled jacket provides damping, insulation, shielding, and cooling! In addition, the water keeps the long-grain, oxygen-free copper at constant humidity!

There is a special digital cable that imparts an "analog-like warmth" to the digital signals. And did you know that a speaker wire has to have enough mass for "deep, solid bass," yet be thin enough for "incredibly-transparent highs?"

Now there are even "open sounding" ac power cables, and ac cables for "improved midrange." Also, one comes with a controller to fine-tune performance.

I learned that analog distortion elements exist "apart from the signal." A good digital-ready speaker "separates the distortion elements" and "restores vital aspects of life to the signal."

Speaker cables not only have to be broken in for a week or two, but you have to take another two or three weeks to "get to know your cables." You can get a special CD for \$150 to break in not only your cables, but your whole system. Another CD promises to demagnetize your phono cartridge!

The most incredible product, however, is "Tuning Dots." These 3/4-in. disks contain a "built-in active resonator, tuned to A-440, which cancels resonances in CD-player, CD-transponder, and digital-converter chassis." These are attached to strategic loca-

tions on the outside of your equipment, and promise a 30% to 40% improvement in sound quality.

What surprises me is that these products are designed, sold, reviewed, and purchased by people who are presumably intelligent, educated people. There almost seems to be a New Age mystical quality to some of these products.

And then, of course, there are vacuum tubes. You can buy a CD player with a Class A cathode-follower output featuring selected 6DJ8s. The tubes are visible through a front-panel tube-viewing window. That allows you to enjoy watching the tubes in case you can't hear what they are doing. The tube amplifiers are said to "address the special sonic problems common to CDs."

**KENNETH LUNDGREN**  
*Bloomington, Ill.*

*I bet nobody ever does an A-B-X comparison on these cables. People who waste their money on such expensive trash get no sympathy from me.—RAP*

### Dear Bob:

Here's some sample math questions from the SAT test:

In 1960: "A logger sells a truckload of lumber for \$100. His cost of production is 4/5 of this price. What is his profit?"

In 1970 (traditional math): "A logger sells a truckload of lumber for \$100. His cost of production is 4/5 of this price. In other words, \$80. What is his profit?"

In 1970 (new math): "A logger exchanges a set L of lumber for a set M of money. The cardinality of the set M is 100, and each element  $m \in M$  is worth \$1. Make one hundred dots representing the elements of the set M. The set C of costs of production contains 20 fewer points than the set M. Represent the set C as a subset of M, and answer the following question. What is the cardinality of the set P of profits?"

In 1980: "A logger sells a truckload of wood for \$100. His cost of production is \$80, and his profit is \$20. Your assignment: Underline the number 20."

In 1990: "By cutting down beautiful

forest trees, a logger makes \$20. What do you think of this way of making money? (Topic for class participation: How did the forest birds and trees feel?)"

**DAVID R. DE SPAIN, P.E.**  
*Union Electric*  
*St. Louis, Mo.*

*Ah, yes, math ain't what it used to be.—RAP*

## MORE SUMMER FLOOBYDUST

Now, sometimes I have to work with various different computers. I don't have to name names, but some of the ones that aren't Macs, and aren't IBM-types, have some reasonably miserable characteristics. For example, when you put the cursor on a character and hit *delete*, sometimes this miserable piece of junk erases the letter it is ON, and sometimes it erases the letter on the left of the cursor. These computers do not have their DELETE keys in a consistent place—it moves around, from one model to the next. And, of course, it has two keys for DELETE; one works and one does not. When I inquire why these stupid computers work so inconsistently, I am told, "Gee, Bob, that's just how they are; you should be delighted to have such a wonderful computer to work with." Hey, don't get me wrong—I don't hate computers. *They* hate ME; I despise *them*.

But now I'm reading a book, and I find that *my* gripes are just the tiniest lump on the huge iceberg of misery and rottenness. You might just want to buy this book—"The UNIX-Hater's Handbook." If you ever have to work with UNIX, you will already be aware of many quirks within UNIX that cause inexplicable behavior—or—misbehavior. I'm not an experienced user of UNIX, but I get the picture. Just let me print a few quotes....

"UNIX is computer scientology, not computer science."

"C++ is to C as Lung Cancer is to Lung."

"If C gives you enough rope to hang yourself, then C++ gives you enough



## PEASE PORRIDGE

# Ignore Your CPU and You Might Get Burned

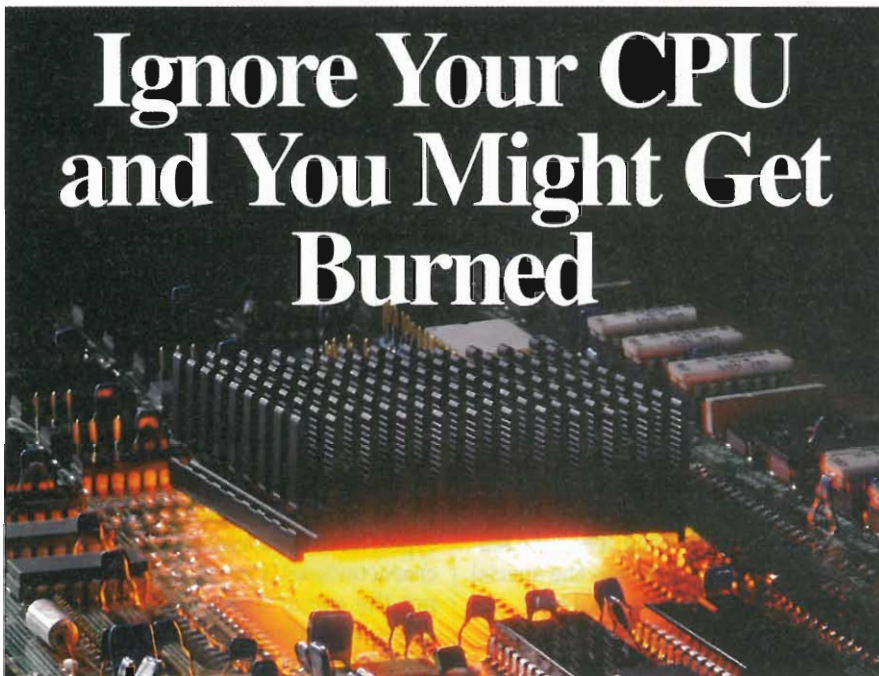

## SOFTFACE™

Today's CPUs operate at higher power levels than ever before. Design them in without a proper thermal interface to your heatsink and they can overheat.

Pre-apply SoftFace to your heatsink for built-in thermal management. The new SoftFace material offers the lowest thermal resistance available today, matching the thermal performance of grease. Typical SoftFace applications include:

### MPUs, CPUs or ASICs used in QFPs, PGAs or BGAs

These components will run more efficiently as heat is maintained at safe operating levels.

Don't get burned! Use SoftFace.

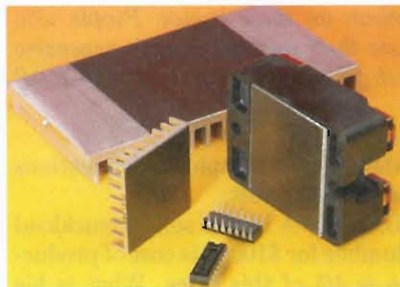

SoftFace is supplied as a coating onto polyester film and can be ordered as a custom die cut part. The material is hotstamped onto a heat-sink for minimum thermal resistance. Call today for samples: 1-(800) 347-4572

## THE BERGQUIST COMPANY

5300 Edina Industrial Blvd.  
Minneapolis, MN 55439  
Tel: (612) 835-2322  
Fax: (612) 835-0430

READER SERVICE 87

rope to bind and gag the neighborhood, rig the sails on a small ship, and still have enough rope to hang yourself from the yardarm."

"Losing a file in a large hierarchical file system is a common occurrence. (Think of Imelda Marcos trying to find her pink shoes with the red toe ribbon among all her closets.)"

"Not having sendmail is like not having VD."

But this book doesn't just say nasty, catty, spiteful, grouchy, terrible things about UNIX and C++. It explains why certain horrible features aren't just little happenings, but are inherently unfixable. Any attempts to patch the horrible problem will just make things worse.

It explains why a UNIX Systems Administrator's job is an exhausting, never-ending, thankless task. "Unix was developed in a research environment where systems rarely stayed up for several days. It was not designed to stay up for weeks at a time, let alone continuously. Production-style quality assurance, so vital for third-party application providers, wasn't part of the development culture."

This is a dense, well-thought-out, well-reasoned book of 315 pages plus index. And I'll save the best quote, by Robert Cringely (*InfoWorld*) for last:

"If the automobile had followed the same development as the computer, a Rolls-Royce would today cost \$100, get a million miles per gallon, and explode once a year killing everyone inside." If you have to work with UNIX, *know your enemy*. Buy this book.<sup>1</sup>

All for now. / Comments invited!  
RAP / Robert A. Pease / Engineer

Address:  
Mail Stop D2597A  
National Semiconductor  
P.O. Box 58090  
Santa Clara, CA 95052-8090

### References:

1. *The UNIX-Hater's Handbook*, by Simson Garfinkel, Daniel Weise, and Steven Strassmann. ISBN # 1-56884-203-1. Paperback, \$16.95 plus tax and mailing. IDG Books, 155 Bovet Rd., Suite 310, San Mateo, CA 94402; (800) 762-2974; fax: (415) 358-1260.



# WHAT'S ALL THIS BIPOLAR STUFF, ANYHOW?

Obviously, since many of the circuits the world needs have already been done with bipolar transistors, it's no surprise that much new study is devoted to CMOS transistors and technology. Lots of excellent, new ICs just happen to be done in CMOS, but only a handful of people even pay attention to what kind of transistors were used. But there are occasions when much bragging is made to show that CMOS is doing new things that could never be done before. It seems that we never get to hear much about bipolar transistors these days. Bipolar is dead, and don't think anything about that. Nobody is doing any new circuits with bipolar transistors. The (bipolar) king is dead—long live the new (CMOS) king.



**BOB PEASE**  
OBTAINED A  
BSEE FROM MIT  
IN 1961 AND IS  
STAFF  
SCIENTIST AT  
NATIONAL  
SEMICONDUCTOR  
CORP.,  
SANTA CLARA,  
CALIF.

Now, however, I must bring in the old quote by Mark Twain: "The reports of my death have been somewhat exaggerated." The bipolar transistor is *not* dead. What makes me so sure of this? Well, I've been serving as a member of the IEEE's BCTM, the Bipolar & BiCMOS Circuits & Technology Meeting. This is a group that has a conference in Minneapolis every year, around October 2. We get about 300 people to show up, and about 50 people give technical papers on various as-

pects of Bipolar technology. There are papers on Analog and Digital Circuits, Modeling, Device Physics, Power ICs, New Processes, etc. It's a pretty good get-together, and everybody learns *something*.

For the last several years, I attended the Conference and helped run a couple of technical sessions. I was on the way out the door, as I had served as a member on the Analog subcommittee for 5 years (which is long enough for anybody), until I was elected General Chairman of the conference for the year ending 3 October 1995. So now I'm a nice, polite figurehead, and I get to write nice letters of commendation, and nice letters of invitation, and sign contracts, and help the committees get organized to select the technical papers, and put my initials on the budget, etc. Boring.

I actually have been able to do a couple of interesting things, though. The General Chair gets to invite some of the speakers. The first morning of the Conference, we need a Keynote Speaker to talk about Bipolar Technology, and tell us where we are, and where he thinks we're going. I started calling up experts on Bipolar Technology from a list of several suggested experts who would be good speakers. The first guy already had several lectures planned this fall, and the second was too busy. And the third one had branched off into MOS. The fourth one was, as his boss explained, just too busy. At this point, I was not nervous, nor was I panicking, but I sure was amused. OF COURSE, if there was a guy who knew a lot, he would be awfully busy. So I asked around the industry.

I found one guy who proposed a good topic, and he even knew a guy who could present it. It turns out that Ken Sodomsky has just retired from his position as Senior Staff Scientist at AT&T Labs, this spring. He knows a lot about bipolar transistors. And Ken is going to tell us why bipolar technology is *not* dead, after all. In fact, some of the new bipolar process developments are very lively in the high-end RF channels, such as wireless communications, up at 2 or 4 GHz. These bipolars are made with some of the new submicron process technology made feasible by the newest submicron CMOS. Using this, the bipolars have superior noise, excellent high-frequency response, and better transconductance, at low current levels. (Yes, MOSFETs are still improving, better than ever, but for many applications, especially where you need good  $g_m$  per milliamp, the bipolars are still ahead.) So if you want to hear about these cases where bipolar is outdistancing its old performance as well as CMOS, be sure to drop in to Minneapolis in October.

Then, after the Keynote Address and after a few hours of technical sessions, we all get together for lunch. (Admission is included free with the registration.) Every year we have a lunchtime address by somebody who knows the industry, and has a good sense of humor. In previous years we had guys like Tom Frederiksen, Jim Williams, George Rostky, John Shier, Max Hauser, and Bob Pease. This year, I started asking people back in December—and I had about the same kind of luck as with finding the Keynote speaker guy. The first three guys on the list were busy, or unavailable. Then I got down to the fourth guy on the list—the person I really wanted—Charlie Sporek.

I made my pitch to Charlie. He asked when, where. He thought about it. Even though Charlie is retired from being head of NSC, he's still a busy guy. He's starting to put together a book about Silicon Valley, and the Semiconductor business. Now, *that* is a book I will want to

# MORE POWER

## Unity Power Factor Front End



for your AC to DC applications

### HARMONIC ATTENUATOR PHA1

- Universal Input (85-260 VAC)
- Power Factor .99
- Efficiency greater than 90%
- Regulated Voltage Output (365VDC)
- Use with PICO DC-DC Converters for up to 500 Watts of distributed power from 3.3-100VDC

PICO's PHA1 is the perfect match for universal AC inputs to your worldwide DC applications. Used with PICO's LPD, PD and HPD series of DC-DC converters you can obtain a variety of DC outputs from 3.3 VDC to 100 VDC in single and dual outputs. PICO systems optimize size, reliability and cost savings.

Delivery—  
stock to one week

See EEM or send direct for **Free PICO Catalog**.  
Call toll free **800-431-1064**  
in NY call **914-699-5514**  
FAX **914-699-5565**

**PICO Electronics, Inc.**

453 North MacQuesten Pkwy., Mt. Vernon, N.Y. 10552

READER SERVICE 125

## PEASE PORRIDGE

read when it comes out in a year or two. (Heck, I will probably buy 100 of his books and sell autographed copies, if I can get Charlie to agree to the autographing.)

The good news is, Charlie finally agreed to give this lunchtime lecture. His lecture will be a preview of some things that will be in his book—a quick peek into it. Charlie says he is going to shoot from the hip, and talk about the early days of the Semiconductor Industry in Silicon Valley. I'm *really* looking forward to this.

So, back in May, we had our Paper Selection meeting, where we studied all of the technical papers that were submitted—about 80—and decided which were the best 40 or 50 to include. For example, we have papers on a 23-GHz frequency divider, a 12-GHz Gilbert mixer, a 12-GHz downconverter, and a 2.4-GHz receiver/demultiplexer. If you're trying to RUN at SPEED, at low power, using just CMOS, look in your rear-view mirror, because the Bipolar guys are coming up the passing lane. There are several papers on low-voltage and low-power circuits. There are papers on high-voltage and high-power circuits. There are papers on new techniques for modeling and extraction. There's even an RF amplifier and some new op amps! A couple of stimulating evening panel sessions also are on tap.

For the first time, there will be a short course available. For up-to-date info on state-of-the-art Wireless and High-Speed Communications techniques, check out Robert Swartz's class on Wireless Opportunities, Ico Koullias' class on Circuit Design, and Hans Stork's discussion on Process Technology.

So, if you want to keep pretending that Bipolar is dead, do *not* come to the BCTM Conference in October. Do NOT attend any of the presentations on new bipolar technology. Do NOT ask Jan Jopke, the BCTM's administrative coordinator, for complete information. Do not mail her a request at 6611 Countryside Dr., Eden Prairie, MN 55346. Do not fax your request to (612) 934-6741. Do not even send an e-mail to the [jjopke@aol.com](mailto:jjopke@aol.com) address. Do not leave

a request on her phone machine at (612) 934-5082. Now have we got that all straight? (Conversely, if you are thinking about attending, this is a good time to shop for cheap air tickets. And if you register before September 15, you save about \$50.)

Now, to end with, I shall recite an old esaeP's fable:

A group of engineers were debating about which animal is the fiercest. One engineer said the tiger is the fiercest animal. Another argued that the lion is much fiercer. Along came a marketing guy. He said, "You guys are all wrong. The fiercest animal is the Bipolar Bear." Everybody looked at him quizzically. "Yes, the Bipolar Bear is the biggest, meanest, orneriest, fiercest animal that is, and he has a head on both ends. That's why he is called the Bipolar Bear."

Everybody shut up and looked thoughtful. Finally one engineer asked "...but...if he has a head on both ends...how does he...*eliminate*?" And the marketing guy said, "Well, he *doesn't* eliminate. And that is *why* he is the biggest, the meanest, the fiercest, the orneriest...." So if you see a fierce circuit made with npn and pnp transistors, and it is really mean and ornery, perhaps that might be because it is a Bipolar Bear.

All for now. / Comments invited!  
RAP / Robert A. Pease / Engineer

Address:  
Mail Stop D2597A  
National Semiconductor  
P.O. Box 58090  
Santa Clara, CA 95052-8090

## MORE SUMMER FLOOBYDUST

I originally wrote, in the first draft of my column on Electric Cars, that when a modern flywheel made of high-tech carbon fiber is run at excessive speed, it may fail, but it does NOT explode into vicious shrapnel. Instead, it turns into a big blob of molten cotton-candy. Unfortunately, this note was omitted from the published version. So several people wrote in to ask, "Isn't such a high-energy flywheel extremely dangerous?" And the answer is, no.—RAP



PEASE  
PORRIDGE



# BOB'S MAILBOX

## Dear Bob:

Of all the features in *Electronic Design*, I enjoy your column the most. While I don't always agree with everything you print, it is refreshing to find an honest engineer that does not simply go along with all the hype that is out there in great abundance. I was quite disappointed when *Electronic Design* redesigned their front cover—and in the process removed "Pease Porridge" from the front cover. I really enjoyed your June 13, 1994 comments on Fuzzy Logic, which I promptly routed to all of the engineers in my group. (Afterwards, my boss scolded me, and now I have to take a course on Fuzzy Logic for punishment. But it was still worth it!)

Today I am writing you concerning your March 20 column on the "Robust Method." I, too, have been indoctrinated on the "Robust Method." As I understand it, it is simply a refinement of the "Taguchi Method," a sort of *cook-book* method for *design of experiments* (among other things) which, in turn, have roots in Dr. W. Edwards Deming's philosophy. (By the way, orthogonal arrays are not unique to Taguchi; *design of experiments* also uses them.) While I have found much value in these philosophies, they often go too far when they entirely replace compensation with optimization.

You really "hit the nail on the head" when you said that simply optimizing the process to reject variations is not enough, and that compensation should not be ignored. Clearly, the prudent engineer does not rely on one technique (tool) to solve all problems in the same manner—rather he or she will use *optimization* (using design of experiments) when appropriate, and/or *compensation* (feedback control) when it is appropriate. Thus, any good designer will have *both* in his toolbox, and must understand the engineering trade-offs between the two in order to make the most judicial choice of tools for each project.

This is precisely the advantage offered by *Quantitative Feedback The-*

*ory* or QFT. Though it was developed over 30 years ago<sup>1</sup>, it has been largely ignored by the controls community—that is, until recently. One of the basic premises of QFT is that the amount of feedback used in a design should be precisely tuned to the amount of uncertainty and/or nonlinearity in the system.<sup>2</sup> That is, if a system is perfectly linear, time-invariant, and with no uncertainty, then there is no need for feedback control. The engineer should *leave* feedback in his toolbox, and reach for another more appropriate tool—perhaps optimization. On the other hand, if the process needs to be linearized and autozeroed, or the process variation needs to be reduced—beyond that which can be achieved through simple optimization—then feedback control is needed (assuming that an appropriate feedback sensor can be found).

Thus, the sole purpose for feedback control is to handle large amounts of uncertainty, and/or nonlinearity, and/or time variation. Yet for many years, QFT was the only theory offered with *quantitative* design for uncertainty.<sup>3</sup> (It is lamentably ironic that many of the greatest contributions to art and science have gone unnoticed until long after the artist/scientist/mathematician has passed on. For example, it took 30 years for the scientific community to acknowledge Maxwell's equations of electromagnetics.) Fortunately, however, Dr. Horowitz is still with us, and the controls community is starting to take note of what is arguably the greatest contribution to control theory since Bode.

Now, back to "Robust Design." The antipathy for compensation among "Robust Design" advocates originated with Dr. Deming. In his book *Out of the Crisis*, Dr. Deming explains his objection to compensation. He said: "Gadgets and servomechanisms that by mechanical or electronic circuits guarantee zero defects will destroy the advantage of a beautiful narrow distribution of dimensions. They

slide the distribution back and forth inside the specifications limits, achieving zero defects and at the same time driving losses and costs to the maximum."<sup>4</sup>

He goes on to "*prove*" his theory by citing the example of the *Monte Carlo funnel experiment*.<sup>5</sup> In this example, he builds four different "control systems" for controlling the distribution of marbles as they fall through a funnel and land on a table below. The object is to minimize the variation in the locations where the marbles come to rest on the table. The first "control system" simply leaves the funnel in the same location. The other three systems become progressively more complicated (and presumably better). All four systems are simulated, and *Shazam!*, the first control system has the tightest distribution, and the more complicated the system, the worse the distribution. From this archaic example, Dr. Deming expects us lowly engineers to conclude that the best feedback system is none at all. That is, leave the darn thing alone you stupid feedback engineers!

At first, being a feedback engineer myself, I personally took offense with Dr. Deming's conclusion. However, I have since found it in my heart to forgive Dr. Deming because I feel his conclusions are actually based on valid observations, rather than this faulty example. Coming from the world of manufacturing, Dr. Deming undoubtedly ran across many empirically designed feedback systems that actually *did* make process variations and/or costs worse than if they had just left the process alone.

But, to make broad-sweeping generalizations about feedback on the basis of a few (or even many) improperly designed control systems is clearly wrong. Modern control theory has become so complicated that most engineers abandon any attempt at analytical control design, and resort to empirical design methods utilizing such tools as PID and Fuzzy Logic. QFT, on the other hand, has restored the analytical design of control systems to a





## Need some help with that?

Turn your  
excess inventory  
into a  
tax break  
and help  
send needy  
kids to college.

Call for your  
free guide  
to learn how donating  
your slow moving  
inventory can  
mean a generous  
tax write off  
for your company.

Call (708) 690-0010

**EAL**

P. O. Box 3021  
Glen Ellyn, IL 60138  
Fax (708) 690-0565

*Excess inventory today....  
student opportunity tomorrow*

## PEASE PORRIDGE

very intuitive and practical level with no sacrifice in power. Dr. Deming does, however, have a valid point in that poor feedback design or an improper calibration procedure—one that makes adjustments based on too few samples—does indeed make the process worse. *So what else is new?* Thus, the conclusion *should* be “leave the darn thing alone, unless, of course, you happen to know what you are doing.”

There are basically two faulty assumptions in this example. One is that “more is better”—that is, the feedback engineer expects that the more complicated control laws are inherently better, which of course, is “bull-bleep.” Secondly, all three of the “control laws” postulated by this example are good designs—NOT! Any freshman control engineer can point out that none of his designs have any basis in control design theory.

While I have great respect and appreciation for the contributions of Dr. Deming, he clearly “missed the boat” on this one. Yet, this flimsy argument is (as I have been told by experts in Robust Design) the basis for the commonly held belief that *optimization* via “Robust Design” is inherently superior to *compensation* via Feedback. I hope this letter will be helpful in dispelling this myth.

**ANTHONY BENTLEY**  
*Sandia National Laboratories*  
*Albuquerque, N.M.*

1. Horowitz, Isaac, *Synthesis of Feedback Systems*. Academic Press, Orlando, Fla., 1963.

2. Horowitz, Isaac, *Quantitative Feedback Design Theory*. QFT Publications, Boulder, Colo., 1992; p. iii.

3. *Ibid.*, p. iv

4. Deming, W. Edwards, *Out of the Crisis*. Massachusetts Institute of Technology Center for Advanced Engineering Study, Cambridge, Mass., 1982; p. 141-142.

5. *Ibid.*, p. 327-333.

*As I've said, THINKING beats the heck out of a silly doctrinaire response. I don't understand all of QFT, but it's going in the right direction.—RAP*

**Dear Mr. Pease:**

Having read your column and that of Mr. King in the March 20 issue (and already years ago your first column)

concerning the robust method, I think the whole difference can be reduced to a simple misunderstanding. Watching U.S. publications from the outside (Europe), I see every good idea praised as a philosophy and every new approach as a panacea. As this self-selling has continued for many years, it seems obvious that the philosophers' stone has already been invented there and all problems are vanished into obsolescence.

Correspondingly, Mr. Taguchi and Mr. King follow exactly their method of “maximizing the intended function”—but *their* intended function or desired effect is to make money on their method. *Your* intended function is a working circuit, which is a definitely unintended function or side effect for Mr. Taguchi et al., and therefore ignored. Consequently, they also developed a “robust behavior” against unwanted critics—so don't be surprised not to get an answer from your Taguchi Lecturer. The system is working, only the target is different! As mentioned in the above paragraph, the long-term outcome may also be different....

By the way, the same issue of *Electronic Design* contains two more papers on similar “side effects” of short-sighted, dollar-return orientation: On page 109, “My Barber Looks At Business,” and on page 104 in Mr. Trudel's column. As an engineer in R&D, I need not mention which way I prefer. Continue to be an advocate of proper design rules.

**PETER MAYER**  
*Vienna, Austria*

*The word “doctrinaire” means following a doctrine or theory blindly, no matter how badly it works in the real world. The antidote for that is thinking, and especially critical thinking. So don't just believe what an expert tells you. I consider Mr. Trudel and Mr. Burge my best allies in this counter-crusade.—RAP*  
All for now. / Comments invited!  
RAP / Robert A. Pease / Engineer

Address:  
Mail Stop D2597A  
National Semiconductor  
P.O. Box 58090  
Santa Clara, CA 95052-8090

## PEASE PORRIDGE

# WHAT'S ALL THIS CARPAL-TUNNEL STUFF, ANYHOW?

About 20 years ago, I was working on manufacturing methods. I had designed a new VFC circuit with a new printed-circuit layout. Not only was it a good circuit with a very effective design, it used just a handful of parts and the layout was improved for easier, cheaper manufacturing. I turned it over to the manufacturing engineers, and was very surprised when they listed the estimated assembly time as *longer* than my previous, comparable circuits.

I confronted the manufacturing manager. Armed with my computa-



**BOB PEASE**  
OBTAINED A  
BSEE FROM MIT  
IN 1961 AND IS  
STAFF  
SCIENTIST AT  
NATIONAL  
SEMICONDUCTOR  
CORP.,  
SANTA CLARA,  
CALIF.

tions, I showed him that this circuit should definitely take *LESS* assembly time, as I was using *their* list of individual component assembly times. According to these rules, if installing a resistor flat on the board was supposed to take 15 seconds, but installing a resistor on end was supposed to take 20 seconds, and I only built in horizontal resistors in this layout instead of the older vertical resistors of previous layouts, then they had better have a good reason not to say the assembly time would be shorter.

I got a big runaround. They never did come up with any satisfactory or rational reason, and they kept insisting they could set any arbitrary num-

ber they wanted to. I concluded the whole mess was completely corrupt. I mean, several other engineers and I had designed circuits that were supposed to have a *LOWER* assembly cost, and after they got in production we were told they actually had a *HIGHER* assembly cost. So if we thought we had done our jobs in designing a new, cheaper, more competitive product—and if the manufacturing guys, without any factual basis, were able to say the part was *MORE* expensive to make—then we could not possibly do our jobs. They were using a warped yardstick, and we weren't permitted to question them. That was the year about 10 engineers left Philbrick, and I was one of them.

But I did get to work with a couple fairly smart manufacturing engineers. We discussed why one design was more expensive to build than another. In the Philbrick tradition, we didn't just install a 1/4-W carbon-composition resistor in the board, like all of the other manufacturers. The assembler had to scrunch the leads *really* tight, and put the resistor into two 0.030-in. holes spaced exactly 5/16-in. apart. Now, every rulebook I ever saw for installing a resistor that has a body 1/4-in. long allows 3/8-in. space minimum between the mounting holes—and preferably 7/16 or 1/2 in. for ease of assembly. However, at Philbrick, we bent the leads good and hard, and stuffed the leads in, and we never had any significant problems. No reliability problems. It did take more care and assembly time, though. But we always thought it was well worth it—because we were able to pack in more transistors, more Rs and Cs, more diodes, and a more complex circuit, getting higher performance

than any competitor that used conservative spacings on their layouts. We always laughed when we saw pc boards with as much as an eighth or a quarter of an inch between components! How absurd!

Then, after the assembler stuffed in the part, she had to bend the leads over, flat and tight, and cut off the leads with her little 4-1/4-in. diagonal nippers. This was to make sure the resistor did not fall out, and to provide a good place for the solder to flow and make a good joint between the lead and the foil. The engineer who was working with me said that some of the assemblers got really sore in their wrists and had to leave their jobs. Other assemblers never had any such problem. That was my first introduction to what we once called Repetitive Stress Syndrome, or Carpal Tunnel Syndrome. (The word "carpal" means pertaining to the wrist.) These women who had to make 500 or more snips per hour, without much of a break, were doing lots of work with their wrists, and when they weren't snipping, they were grasping those nippers, clutching them tight. Some of them got along with that work just fine—and some just could not take it.

Personally, I always enjoyed building things and installing the resistors and bending the leads exactly right, and snipping off the ends. I never got quite good enough to get up faster than the standard work rate—I was neither methodical nor consistent enough. If I had worked at it for 8 hours a day for a few months, I might have come up with some different opinions. But I had lots of fun, and I learned a lot. I convinced myself that I knew how to design printed-circuit layouts that could be manufactured small and quickly—even though the manufacturing manager insisted that I should shut up because I didn't know what I was talking about.

NOW, if you do certain motions with your hands and they really hurt, and then you get smart and stop doing it and your hands feel better—hey, no problem. BUT a lot of these women not only had real pain, debilitating pain in their wrists, they found that when they stopped, it did NOT get

## PEASE PORRIDGE

better for a LONG TIME!! THAT is not linear—that hurts!! So over the last 10 years, a lot of people have found out about Repetitive Stress problems.

Over the last 20 years, lots of people have been doing much more typing, data entry, and word processing. I certainly have been doing a lot more typing. My columns alone take about 50,000 words of typing per year, and my recreational typing almost that much, and my typing at work is comparable. This doesn't seem to bother me at all. But I've talked with people who find that they're doing so much typing that their wrists are going to ruin. They can't drive their car; they can't hold a pencil; they can't put on their clothes. They find that they have to stop and rehabilitate their wrists, and do a completely different type of work, with no typing, until their wrists are recovered. It's NOT a joke, even though it's hard for us sturdy types to comprehend.

Why do wrists get sore? Well, your wrist bones make a little slot or "tunnel"—the carpal tunnel—where your tendons and nerves pass through on the way to your hand. If these tendons go through a great deal of activity and start to swell up, there's no place for them to go, so they expand and start to crush the nerves. If this doesn't stop, these nerves can be badly damaged, and may recover very slowly.

So my first advice is, if you're doing a lot of typing or any other repetitive hand motion, and your wrists are getting sore, STOP IT REAL FAST. Because it ain't likely to get better, and it's likely to get worse. AND, worst of all, it will probably not get better very quickly when you stop. So, it's important to STOP and get good medical advice. Now, I'm not a doctor. But, from what I've read<sup>1</sup>, if you stop for a good while and let your wrists get better, and then take precautions, you may eventually be able to return to that type of work. For example, you may have to get a different type of ergonomically friendly keyboard. You may need a wrist-cushion to cut the strain on your arms. You may have to force yourself to take plenty of breaks, and cut down considerably on your total typing. But you will have a chance to recover—something you

won't have if you just try to gut it out.

Let me cite a similar example—mountain sickness. When hikers from the western world go to the Himalayas, they go from a hiking experience of 10,000 or 12,000 feet, maximum, to up above 18,000 feet or higher. I mean, almost none of us has any experience at sleeping above 14,000 feet, but in Nepal or Kashmir or Tibet, any serious expedition goes way above that. As the expedition ascends, some people start feeling lousy and weak, with trouble breathing, etc. Many young hikers think they're so tough, they think they can just tough it out and climb higher the next day. Those are the ones that die. The ones who get good advice from their expedition leader, or their medical guys, and go down the mountain—they all recover. The chances of death or serious injury are negligible if you descend fairly promptly. Young bucks hate to do this—they hate to admit to any weakness. But you HAVE TO descend—there's no known medical treatment to "cure" mountain sickness. (Some expeditions bring along a "Gamow bag," a sort of inflatable sleeping bag that can add some pressure and let a sick person get some of the effects of lower altitude without descending, but that's just a temporary deal.)

Likewise, if your wrists feel like they're being ripped up by repetitive stress, you must stop, or they will NOT get better. Stop, and consult with medical experts who know about this stuff. Avoid the possibility of permanent nerve damage. Years ago, when people didn't know any better, and even most doctors didn't know about it, ignorance was excusable. Not any more.

Who else does repetitive stuff? Musicians. Most concert musicians and symphony artists do a LOT of practice—sometimes more than is good for them. Some people can take it, while others get damaged. Pianists who use all their fingers and practice until perfection can have this problem. It's not a matter of not trying—it's a matter of trying too hard. Don't be ashamed of stopping. It's not anything that you have any choice about, and it's not a matter of willpower. I ran into one person who did a lot of typing, and I

saw a splint on his wrist. When I inquired, he said that a little typing didn't bother him much, but he discovered that he slept at night with his wrist bent down as an unconscious habit. This wound up, when combined with a lot of typing, nearly wrecking his wrists. When he put on a short splint for typing, PLUS a long splint for sleeping, to prevent him from cocking his wrist hard for hours on end, the problem diminished to very manageable levels. Then, with an improved keyboard and rest pads for his wrists, he could do some typing. I know that I sometimes cock my wrist, a little bit one way or another, when sleeping. But it doesn't seem to have caused any problems—not yet anyway.

One time I discovered I was getting a real pain in my neck. I finally figured out why—I was assembling some special circuits at my kitchen table. I'm just near-sighted enough that I wanted to get my best view by bending my neck over to get a close-up look at this work. I decided to put my work on top of a stack of four big telephone books. The neck problem went away.

So just remember—pain is one way for your body to tell you that you ought to STOP what you're doing. Hey, I'm not a doctor, but I'm smart enough to warn you that in certain *nonlinear* cases, it's important to stop first, see a doctor, and ask questions before you resume your work—or else! For more information on Carpal Tunnel Syndrome, ask your company's medical advisor, or ask your doctor. Or buy the inexpensive brochure listed below.

All for now. / Comments invited!  
RAP / Robert A. Pease / Engineer

Address:  
Mail Stop D2597A  
National Semiconductor  
P.O. Box 58090  
Santa Clara, CA 95052-8090

#### References:

1. "Carpal Tunnel-Syndrome—Relieving the Pressure in your Wrist"—send \$2.50 to Krames Communications, 1100 Grundy Lane, San Bruno, CA 94066-3030.



## PEASE PORRIDGE



# BOB'S MAILBOX

### Dear Mr. Pease:

Your recent column in the May 30 issue reminded me of something that has been bugging me for a long time. Growing up, I can remember my father telling me quite often, "Use a little common sense." I never thought to ask him, "Where do you get common sense?" "What does it look like?" "How much does it cost?" "What quantities does it come in?" "How is it packaged?" "How much should I use?" "Can I get a volume discount (a buck-two-ninety-five for quantities of 1000)?" And the final question, "If it's so common, how come hardly anybody has it?"

From the way things are going, I guess I could use a couple of truckloads. Now I just need to figure out a place to store it.

### DALE LEE

Aurora, Colo.

*Re: Common Sense. "Where do you get it?"—Pain and sweat. "What's it look like?"—Almost invisible. "Cost?"—Pain and sweat. "What quantities does it come in?"—Drips and drabs. Packaged in a thimble. "How much to use?"—You can never have too much. "Volume discounts?"—Heck, no. And, "If it's so common, how come hardly anybody has it?"—Maybe they used it all up. And if you get a truckload, you can store it at my house.—RAP*

### Dear Bob:

Obviously, Kenneth Lundgren is a newcomer to the world of super-audio products (your July 24 column). Listen here, Ken, what you need are mammoth, atomic speaker cables. These are super cables that have been zapped with thousands of amperes from shorting a 3-KV, 100- $\mu$ F capacitor to ground via the cable. This realigns the electrons and reduces cable resistance.

Also available is a foot switch that, upon activating, switches out a solid-state power rectifier and substitutes a 5U4G rectifier for a mellower sound.

And Ken doesn't know about the special silver wire with teflon insulation.

This improves the high-frequency response of the amplifier. As does output transformers wound with silver wire.

Reminds me of the days of the CB craze. You could buy a tube of SWR grease. This stuff, when rubbed along the coax to the antenna, would reduce the SWR. Neat, huh? Lotsa things out there you stuffy engineers don't know about.

### WILLIAM ORR

W6SAI

Menlo Park, Ca.

*Oh, there's lots of whizz-bang things out there I don't know about. The emperor's new hat, raincoat, and galoshes. And the emperor's new stereo...and speaker cables....—RAP*

### Dear Bob:

Hey, your piece on post-office efficiency just arrived; I felt compelled to comment. While I haven't examined post-office budgets, ever, I imagine that a lion's share of the postal dollar goes towards paying the salaries of the mail carriers. (These are the folks who bring you your mail to the front door.) Another whopping piece of their money must go towards fuel and vehicle expenses to carry the carriers around (or to and from) their routes.

This makes me wonder why it is that we get free portal-to-portal mail service (which has to be very expensive) while, if we instead elect to undertake to pick up our mail at the post office (thus relieving the department of the burden of home delivery), we must pay extra for it as though it were a privilege.

Don't you think they got it backwards? We should all be given a free P.O. box and have to pay extra for home delivery. Just ponder how much money that would save in mail delivery costs. I know this has nothing to do with electronics, but you started it. I didn't.

### BILL STURGEON, P.E.

Petalis, Ca.

*Bill, your vice-versa argument makes too much sense, which explains why the Postal Service hasn't figured it out.—RAP*

### Hi Bob:

Re: "What's All This Security Stuff, Anyhow?" in the June 12 issue. I don't think this method is horribly original, but there is a class of access security where the system sends a puzzle, and the user solves the puzzle by using the password, so that the answer, but not the password, is transmitted.

For example, if the puzzle transmission is CLXTDRAP and in the password is "CAT," the solution would be 132, the order of the password letters in the puzzle. Expand this some, and even the weasel looking over your shoulder won't be able to figure it out if you solve it in your head. Of course, if you wiretap enough successful attempts, you will know the password. Nothing's perfect. But something beats hell out of nothing.

I am aware of your attitude toward e-mail, and the reasons why. But ever since my government client forced me to enter this game, I have found it a hell of a lot more effective than banging it out on the computer, printing it, addressing and stamping the envelope, and stuffing the results in the mail. I haven't become so popular that I need some sort of B.S. filter on the receiving end of the system, and people paying me have the right to send me all the pointless and redundant traffic they want. I just crank it into the rates.

### BILL SCHMITT

via e-mail

*Bill, I think any do-it-yourself security scheme that a thief has never seen before will work better than anything you can buy. Best solution—put your hot new PENTIUM in an old XT case?—RAP*

All for now. / Comments invited!  
RAP / Robert A. Pease / Engineer

Address:

Mail Stop D2597A  
National Semiconductor  
P.O. Box 58090  
Santa Clara, CA 95052-8090

## PEASE PORRIDGE

# WHAT'S ALL THIS PEASE-ISM STUFF, ANYHOW?

**N**ote: It is alleged that while Bob Pease was on the trail backpacking up at 9600 feet, his e-mail account was mugged by colleagues. They were led by Carlos the Jackal, who went into Pease's files and sent in this column. When we at Electronic Design queried Bob on the veracity of this column, he tried to deny everything. But his colleagues said, "He can't deny that; he talks like that all the time." We'll let you readers decide who is telling the truth...

WHAT do you have to listen to when you work for Bob Pease all day? Well, here's a sampling of Pease-speak



**BOB PEASE**  
OBTAINED A BSEE FROM MIT IN 1961 AND IS STAFF SCIENTIST AT NATIONAL SEMICONDUCTOR CORP., SANTA CLARA, CALIF.

that can also act as a useful guide for anyone having to deal with the Great Czar:

• When Pease says he is going to talk to someone, or go to a meeting, or has to go work on a project: "Excuse me, I have to chase a giraffe..."\* or, "...chase some giraffes..."

• Let's discuss or debate this soon (or, maybe now): "Let's haggle..."

• A NICE way of saying I think you're wrong: Is that right, Mr. Pease? "...Roughly ... Roughly..." implying, "Yes, that is right, but not exactly right."

• He is going to discuss an important issue with someone: "I'm going to go chew on his ankles." or, "... on her ankles."

• To stimulate the supply voltage with a transient: "Bang on the rail, and record how much the output wiggles."

• Statement of frustration, or dissatisfaction with workers from certain other groups: "Hey, when I buy this company, like next month, I'm gonna change this—as soon as my check for \$900,000,000.00 clears."

• When he is trying to make a point, or get an idea across: "Did I tell you the story about..." or, "Once upon a time..." or, "Is that the right solution? Maybe—but look at this." or, "Here's another angle." or, a one-word suggestion for a different approach: "Angle."

• When he wants to talk to you for 3 to 15 minutes: "Got a millisecond?"

• Let's go ahead and do it: "Let's wing it."

• Anyone who has a rough time solving a tough problem: "Poor bastard..."

• Anyone he feels sorry for: "Poor bugger..."

• Bob's way of using an analytical approach to getting a customer to understand. Customer: "Bob, is there a difference on how I connect my inputs to the amplifier?" Bob: "Yes, there is!" Customer: "I don't see a difference." Bob: "Damn it, if I hit you over the head with a baseball bat and if I asked you, 'Do you want me to stop or slow down?,' is there a difference?"

• When things are going crazy he will say: "What a zoo."

• Don't ever say he can't do it, or else he will respond like this: "Show me where it says I can't do it." or, "Don't you tempt me."

• When he thinks of an idea at that moment: "Ah, yes!... paper, paper!!" or, "Give me five sheets of paper!"

• When something takes too long to

get here, or if it got lost on the way, he will say: "It must be on the station wagon."\*\*

• Favorite statement about a potential problem: "Is it a killer?...I don't know!!!...but I'm not worried."

• He calls a problem similar to one that he has seen before: "A classical problem."

• Let's talk to him/her on this issue: "We need to heckle him/her on this."

• After a hectic week, Bob sometimes asks: "Well, did we do more good than harm this week?"

• When something is found wrong on a part, or some really crazy or unbelievable data happens, Bob will comment: "I really haven't had any thing to drink this morning, but..." or, "I usually don't get drunk in the mornings... but this morning might be a good time!!!"

• Bob is a true team player, well—providing one little thing (according to the message on his sweat shirt):\*\*\* "Team effort is...a lot of people doing what I say!"

• One of Mr. Pease's sales pitches: "Want to buy a buuuuk??? book ...book...buk?" (clucking like chicken).

• Bob normally finishes a conversation with a positive statement like: "Damn good questions!" or, "Good start, good start!" or, "Thank you for your inputs!" or, "Keep up the good work... you're doing just fine!" or, "I like your data!" or, "Good answer!"

• Mr. Pease rarely uses foul language. And he will not admit that he destroyed a part. Instead, he will say: "I damaged the bejesus out of it!"

• Secretary: Yes, I can connect you to Mr. Jones. Who should I tell him is calling? "Just tell him, this is Bob Troublemaker!"

• Is the output of this servo loop a nice low impedance? "It's squishy-soft."

• If he sends you a wild memo or e-mail, it's a "Nasty-Gram" or a "Pease-O-Gram."

• If he is in a really grouchy mood, and sends a strongly worded Pease-O-Gram, he is likely to end it with: "P.S. Strongly worded memo to follow."

• Some years back, RAP frequently would express non-confidence in something by saying: "I ESCHEW

## DEVICE PROGRAMMERS



- \*PC based \$139.95, Parallel port connect \$449.95, Stand alone models \$550.00 or \$750.00 gang
- \*Read, Pgm and verify 2716 - 8 Megabit EPROM, all models
- \*Support for micros, Flash, EPROM, 16 bit, PALs, Mach (call for specific models support list or download demos via BBS or internet)
- \*30 day money back guarantee, **FREE** software updates
- \*Technical support by phone Mon - Fri 8am to 5pm PST
- \***Made in the USA**, 1 or 2 year warranty on all parts and labor
- \*Easy to use menu driven software, on line "help" full screen editor
- \*MACROS, Read and save to disk, Split and set options
- \*Internet <ftp://ftp.crl.com/users/ro/needhams>

FOR MORE INFORMATION CALL

### NEEDHAM'S ELECTRONICS, INC.

4630 Beloit Drive #20  
Sacramento, CA 95838  
(Monday-Friday, 8 am-5 pm PST)



**(916) 924-8037**

**BBS (916) 924-8094**

**C.O.D. FAX (916) 924-8065**

READER SERVICE 114

# THE ABILITY TO STOP CHILD ABUSE IS FINALLY AT OUR FINGERTIPS.

Now there's a way you truly can help stop child abuse. Simply pick up the telephone, and call 1-800-CHILDREN. We'll tell you about a totally new kind of prevention program and how you can help where you live. It's already achieving unprecedented results. You can do the same. To learn more, please call today.

**THE MORE YOU HELP THE LESS THEY HURT.**



1-800-CHILDREN



## PEASE PORRIDGE

*xyz, etc....*" However, he said it less frequently after he noticed people often followed his "eschew" with a reflex-action "GESUNDHEIT."

- How can you compare things that are not alike? *"Yes, you can compare apples and oranges."*

- When a project is getting a little behind schedule, he says: *"As the old Farmer used to say, 'We're going to finish up this darn field by 5 o'clock if it takes us all night.'"*

- When someone starts expressing concern about all of the little details: *"Picky, picky, picky."*

- When somebody forgets to give all of the information about a problem: *"Ah, now you are guilty of withholding evidence."*

- Regarding the need to succeed on the first try: *"If at first you don't succeed, cheat. Cheat until caught; then lie."*

- If you start to apologize for working on some crazy project: *"When have I ever criticized you for working on something crazy?"*

- When a workstation or computer provides some erroneous results: *"That computer will never lie to me again—after I throw it off the roof."*

- When somebody asks for a result that is impossible: *"Hey, people in hell want ice water."*

- When a circuit seems to be behaving strangely: *"What do you mean it acts funny? Tell me how much funny."* or, *"Record amount of funny!"* (That's Milligan's Law.)

- What if your signals or power are not connected? *"You can't see it if you don't look at it."* (That's McKenna's Law.)

- Pease's perspective on the concept of enormous projects: *"Don't take on VAST projects with HALF-VAST plans."*

\*\* Story is available on request.

\*\*\* This sweatshirt can be purchased.

All for now. / Comments invited!  
RAP / Robert A. Pease / Engineer

Address:  
Mail Stop D2597A  
National Semiconductor  
P.O. Box 58090  
Santa Clara, CA 95052-8090



## PEASE PORRIDGE



# BOB'S MAILBOX

### Dear Bob:

Re: "What's All This Security Stuff, Anyhow?" in the June 12 issue. You'd like the gun safe I helped a friend install. The safe is made with three-quarter-inch steel and measures about three feet wide, three feet deep, and five feet tall. Still, he was worried that somebody might load the entire safe into a pickup truck and run off with it. So, we bolted it to a wall inside a closet in his guest room. We put four long carriage bolts completely through a pair of 2 x 4 studs in the wall. We put the nuts inside the safe and the round heads on the other side of the wall. If you've ever seen a carriage bolt, you know that there is no easy way to attach a tool to its rounded head. To guard against someone grinding away the bolt heads outside of the safe, we sunk them beneath the sheet-rock down to the 2 x 4 and put plaster on top. It is still possible to open the safe with dynamite or cutting torches, or even rip it out of the wall with heavy equipment and haul it away. But it'd be easier to steal someone else's gun.

One way to make computers more secure is to place the password and the password algorithm in the motherboard ROMs. You'd want the password to be entered correctly at the very beginning of the boot sequence, before the system begins to load anything from disk. Storing the password in battery-backed volatile memory would not be smart because, as you said, it's very easy to disconnect the battery and erase the memory.

If the password were stored in ROM, then the user could never change it. The password would be assigned by whomever programmed the ROM. If you wanted the user to change his password, then EEPROM or flash RAM would be a better choice. If a user forgot his password, his only recourse would be to replace the circuit in which it resides. ROMs, PROMs, and EPROMs are often sock-

eted, which makes the replacement very quick and easy—assuming he's got a new set handy. Flash RAM is usually soldered in place. How easy would it be to get a new set of ROMs with a password that the thief knows? It would be difficult, but not impossible. A determined and technically competent person could do it. However, the average thief would learn to leave computers alone.

Don't forget to protect your software files, too. If you've ever worked late or over the weekend, you've probably noticed that office computers sit unattended for long periods of time. Perhaps less obvious is the security hazard posed by networks. Every file server has at least one—and usually several—superusers that can see every file on the system. Okay, okay, so your employer has guards at all its doors and you are not worried about your co-workers seeing your love letters or electronic tax returns.

What about outsiders stealing your company secrets? Hackers are notorious for breaking into corporate and government computer networks. To them, it's a game with just enough risk to make it thrilling but not so much risk to deter them. The weakest link is usually an employee with a poorly chosen password. If someone does breach the network security, they often go undetected until they wreck something. Remember, too, that e-mail is very insecure. If you depend on the telephone company as part of your WAN, then you'd do well to consider a statement in the book titled *A Man Called Intrepid*. This intrepid fellow supposedly ran British intelligence from New York City during World War II. In the book, he said that the very best intelligence came from the phone company.

So what should you do? Encrypt your data. Commercial software can encrypt your files and your e-mail messages to a degree sufficient to give the NSA heartburn. In my opinion

(though I'm no expert so I'm not sure what my opinion is worth), the best commercial algorithm is the public key encryption code patented by RSA Data Security. There are two keys, one public and one private. The public key gets published in something like a telephone book. The private key is known only to its owner. You scramble a message using your private key and their public key. The result can only be unscrambled by their private key and your public key. An interesting benefit is that the message can only come from one person, providing an effective electronic signature.

**KEN STEWART**

*Engineer*

*Eden Prairie, Minn.*

*Maybe some of the best intelligence and security came from the telephone companies, but some hackers have figured out how to get into their computers. Maybe more encryption is the answer. All evidence indicates that a computer is very hard to make theft-proof, but a hard drive can be encrypted so nobody can use it. Just don't forget your password!—RAP*

### Dear Bob:

Re: "What's All this Security Stuff, Anyhow? Pithy, to the point, and I agree with all that, but...

Over here our thieves have learnt technology! They discovered that computers only fetch \$x/lb. and are hard to conceal. On the other hand, if they just undo those five little screws at the back, and learn a little craft with a small screwdriver, they can stuff their pockets with memory chips and 486/Pentium chips. These can be readily sold in *Trade-It* (a free paper), "486DX50 chip for sale—I just upgraded," or to just slightly less than scrupulous dealers for 75% retail price. This gives a much better return at \$y/lb. (you can work out the local x and y).

There have been many reports in the U.K. of folk arriving at work to find an office full of PCs with their

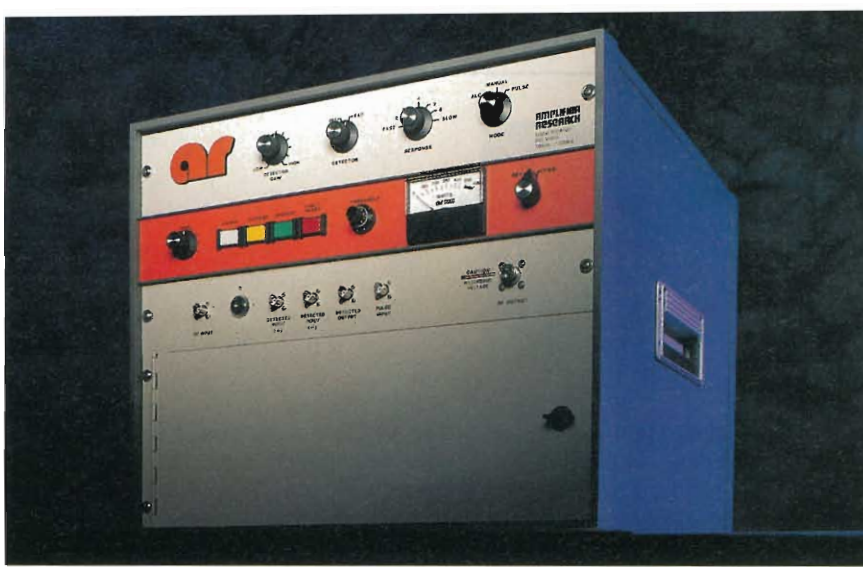

## Not a bird. Not a plane. Just an awesome rf amplifier.

It sweeps. It pulses. It levels. It blanks. It operates manually or by remote control. But most important, it delivers *at least* 500 watts of rf power, regardless of load VSWR.

We designed the new all-solid-state Model 500A100 broadband rf amplifier to be used *wherever* you need reliable rf power over a 10 kHz to 100 MHz bandwidth, including test situations where nothing less than 500 watts will do.

We tested the 500A hard, first by reflecting nearly all forward power back into the amp — it still put out 500 watts (minimum). We shorted its output terminals, then left them open. We couldn't hurt it. It didn't even shut down.

So if you need 500 watts *minimum*, you're sure to get it, which is where we start with any amplifier we build. But just look over the Model 500A100 front panel: gain control; threshold/leveling; pulse input; detected rf input and output; mode selector. A front-panel power meter measures either forward or

reflected power. And a back-panel connector makes it easy to interface to a computer or other remote controller.

The Model 500A100 is one of eight economical broadband rf amplifiers in our A-Series line, which reaches up to 1,000 watts and 250 MHz. One model, the 40AD1, goes all the way down to dc.

Put your wish list together (including all the accouterments) and call us. One of our friendly AR applications engineers will take the call directly. They enjoy challenges. **1-800-933-8181.**

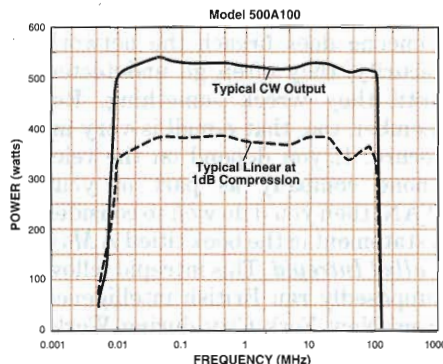

**AR** AMPLIFIER  
RESEARCH

160 School House Road • Souderton, PA 18964-9990 USA  
TEL 215-723-8181 • FAX 215-723-5688

For engineering assistance, sales, and service throughout Europe, call EMV:  
Munich, 89-612-8054 • London, 01908-566556 • Paris 1-64-61-63-29.

READER SERVICE 85

13161

## PEASE PORRIDGE

covers off and stripped of memory chips and/or hard disks.

So, while you're right as far as \$24,000 scopes and stupid thieves are concerned, the real answer has to be for chip makers to thief-proof the high-value components inside. Now if CPUs and RAMs refused to work until you tapped in a password... But, how would you engineer that without causing total chaos to the PC world? And no, I don't want my chips soldered in.

A related, and possibly more solvable, problem is that the police may "know" a dealer has stocks of stolen components, but they cannot prove it in court because there is no way of distinguishing the stolen chips from legitimate ones. Some IC makers, I hear, are moving toward serializing every chip. Will this lead to a system solution?

**PHIL ADDISON**  
*Bristol, England*

*Hi, Phil—maybe computers need keys, locks, and alarms to provide people from getting inside. If a clone maker provides these features, would you buy it? Ask him!—RAP*

**Dear Bob:**

Re: Security. I once met an old timber logger in the Oregon forest. He had a problem with people stealing his cut logs. His solution was to drill a hole in a log, insert a half-stick of dynamite, pack with sawdust, and leave it for the thief. Problem "went away" when the S.O.B. added the wood to his stove.

Is there a digital equivalent? How about the exploding dye-pack of money that banks give to a robber?

**JOHN WAX**  
*Alden Scientific Inc.*  
*Alden, N.Y.*

*I'd have guessed a quarter-stick should be plenty to get the MESSAGE across. But it might be a little harder to do on a computer.—RAP*

All for now. / Comments invited!  
RAP / Robert A. Pease / Engineer

Address:  
Mail Stop D2597A  
National Semiconductor  
P.O. Box 58090  
Santa Clara, CA 95052-8090

# WHAT'S ALL THIS STUPID, DANGEROUS STUFF, ANYHOW?

**R**ecently, I was remarking to a colleague about a small write-up I saw in one of the IEEE publications about some college professors who were trying, many years ago, to make a hard disk. They had somebody fabricate a 36-in. diameter disk of 1/2-in. aluminum, and tried to bring it up to 3600 rpm. The air drag was so much that they had to resort to outrageous amounts of power to pull it up to speed.

I said I had seen an old hard disk, retired from service, at Singer Librascope. It was 4 feet across, and it



**BOB PEASE**  
OBTAINED A  
BSEE FROM MIT  
IN 1961 AND IS  
STAFF  
SCIENTIST AT  
NATIONAL  
SEMICONDUCTOR  
CORP.,  
SANTA CLARA,  
CALIF.

raced at the synchronous speed of 3600 rpm. They must have run that one in a vacuum to avoid the terrible drag losses. My old hiking friend Les Earnest told me this was one of six disks on a horizontal spindle, each of which was 47.5 in. in diameter, 16-in. inside diameter, and 1/2 in. thick, and each weighed 70 lb. Les has one suspended from his living-room ceiling, and uses it for a coffee table.

I've heard of such a disk getting loose and begin spinning on the floor until it gathered up speed and smashed into things... My friend looked around and, seeing it was a quiet time, started to tell me about his long-ago experiences at a Defense Contractor. He had a ball-

bearing that had gotten kind of dirty and crummy, so he washed it in solvent, and made it nice and clean. Then he took it over to an air hose, and opened up the nozzle to clean out the solvent. He held the bearing by the outer race, and as he played the air on the bearing, it began to spin pretty fast. Wow—it got up to a really good whine. He called over to a couple of his pals, “Hey, come over and look at this.” They went over and watched him turn on the air. The bearing began to whine—faster—faster. Suddenly, there was only the hiss of the air, and then silence. The inner race of the bearing was GONE. The balls were gone. Where did they go? They looked all around. They never did find any pieces, and they never did find any holes where pieces would have gone through a wall or ceiling. They decided they were very lucky, and shut up, and went back to work. Later, they learned that company regulations (although unpublished) specified that anybody blowing air onto a ball-bearing like that could get fired—even though this offense was not listed nor defined.

Anyhow, the guy computed that with 100-psi air, you could get the inner races up to about 140 mph. On a 1-in. radius, that's about 20,000 g, and that's not a safe area to expect a steel member not to rip itself to shreds. Those guys were VERY lucky.

Now, this falls into the category of telling your kids, “Don't put beans in your ears.” Or, “Whatever you do, don't put those beans up your nose.” Needless to say, telling a kid not to do something almost ensures that they can think of nothing else. About 19 years ago, Lois Lee, our premier mask designer, told me, “Shouldn't you worry about this problem, Bob?” I

told her, “Don't think about it. Also, don't think about Annapolis, Maryland; and don't think about Pensacola, Florida.” To this day, if I tell Lois, “Don't think about it,” Lois says, “Which one should I not think about, Annapolis or Pensacola?”

So, I'll tell you that you should probably never blow air onto a ball bearing so it can spin at any appreciable speed in order to blow out the cleaning solvent. Blow squarely, transversely, down onto the bearing, or hold both races. Let it turn over, *real* slow. If you insist on doing stupid things, and you want to over-rev a ball bearing, make sure there's no person and no car for at least a half mile in the plane of rotation of the bearing. Make sure the fragments aren't likely to ricochet and hit YOU. Are there any other precautions? Oh, yeah, make sure you don't get caught. Also, if you goof, have a buddy who can apply artificial respiration, and put on a tourniquet, and then drive you to the hospital.

The other classical stupid, dangerous thing to do was proposed by Longfellow: “I shot an arrow into the air. It fell to earth, I know not where.” This story is about the kid who takes his new bow and arrows outside. After his parents warn him not to shoot at cats or other people, he figures out—he can make the arrow disappear! He aims STRAIGHT UP IN THE AIR and lets it fly! For the first 3 or 4 seconds, he looks up in wonderment and satisfaction. Wow—he has done it! The arrow is OUT OF SIGHT. Then after a second of delay, he realizes in horror: That arrow is surely not going to stay up there; it will come back down and, perhaps, *quite nearby*.

He tries not to panic. Maybe he can wait until the arrow comes into sight, and then dodge it. But after two seconds, he realizes it's *much* too risky trying to dodge an arrow coming at you head-on, nearly invisible. So—should he run? Which way? After a couple seconds of panicky indecision, he runs upwind as fast as he can. He almost always survives. But still, it's scary. Under what condition would I shoot an arrow up in the air? Only if I knew of some VERY sturdy beams I could safely stand under. Or a cave, or



# PEASE PORRIDGE

a couple feet of earth. I just do not want to fool around with this.

Now, what if I fired a gun straight up in the air? Well, the bullet is sure to fall back down at a velocity much lower than the muzzle velocity of 400 to 1000 ft/s. So if I could find a large, sturdy tree limb, I would guess that's not an unsafe place to stand, waiting for the bullet to come back down. A while back, I inherited an old rifle, a Remington single-shot .22 rifle. The first thing I did was to install a lock on the trigger so it could not be fired. Then I tried to take it down to the police station to register it, but they said they could not register the gun because it had no serial number. Maybe I should try again?

Anyhow, after I carefully cleaned the barrel, I tried a couple of test shots. I shot at a 2-in.-thick old telephone book. I was impressed when the bullet came out the other side with still a little velocity. I haven't yet set up a ballistic pendulum to measure its muzzle velocity. I have yet to shoot a bullet straight up in the air. So far, I haven't put any beans up my nose. You better not, neither...

Then, a story came rambling through the Internet about the "Darwin Award" nominee: "You all know about the Darwin awards—it's an annual honor given to the people who did the gene pool the biggest service by killing themselves in the most extraordinarily stupid way.

Last year's winner was the fellow who was killed by a Coke machine, which toppled over on top of him as he was attempting to tip a free soda out of it.

And this year's nominee is:

The Arizona (U.S.) Highway Patrol came upon a pile of smoldering metal embedded into the side of a cliff rising above the road at the apex of a curve. The wreckage resembled the site of an airplane crash, but it was a car. The type of car was unidentifiable at the scene. The boys in the lab eventually figured out what it was, and what had happened.

It seems that a guy had somehow got a hold of a JATO unit (Jet Assisted Take-Off), which is actually a solid-fuel rocket that's used to give heavy military transport planes an extra

'push' for taking off from short airfields. He had driven his Chevy Impala out into the desert, and found a long, straight stretch of road. Then he attached the JATO unit to his car, jumped in, got up some speed, and fired off the JATO!! Best as they could determine, he was doing somewhere between 250 and 300 mph (350-420 km/h) when he came to that curve. The brakes were completely burned away, apparently from trying to slow the car. Note: Solid-fuel rockets don't have an 'off'...once started, they burn at full thrust 'til the fuel is all gone.

P.S. What a ride! Can you imagine the excitement? Actually I know someone that did something similar with a racing go-cart engine and a minibike. These engines have a very peaky Torque vs. RPM curve. There was lots of blood, a helmet worn down to the lining, and 6 months of healing."

Well, I haven't yet gotten any confirmation on whether this really did take place, but it *does* sound plausible. But I want to make this point: If a buddy told you he was planning to do this, would you be able to talk him out of it? Would you be able to convince him that 10,000 lb. of thrust for 20 seconds is probably enough to get him in REAL TROUBLE? I would hope so. I checked in some books to find out what ratings are available for JATO bottles. In general, they are MUCH too big and powerful to put on a car. They would give you about 2 g. Even from a standing start, your speedometer would go past 120 mph in about 6 or 7 seconds, and past 180 in 10 or 12 seconds. And Impalas never did have brakes worth a darn—not to mention enough braking to hold back 10,000 lb. at 100 mph. I did find one cute little JATO unit listed, weighing just 85 lb., that put out 5,000 lb. for 2 seconds. A unit that can put out 5,000 lb. for 20 seconds weighed about 650 pounds—not exactly easy to tape onto the back of an Impala. The story begins to sound a little unlikely....

I once read that the young Thomas Edison found a hillside with a road cut into it. He measured the hillside and the cut. He went home and computed that if he came down the hill on his sled, he would have enough speed and trajectory to be able to LEAP over

the cut. He tried it. The sled smashed into the lower side of the cut, and he was, luckily, only very badly bruised. He went home and discovered that he had dropped a decimal place in his computations.

So don't get sloppy with your math when the answer to the problem is not just a point on your grade, but whether you live or die. And don't put too many beans in your ears. (Long needle-nosed pliers, which most of us electronics guys own, can get the beans out without TOO much pain.)

Chester Simpson told me about a duck hunter who was a real cheap-skate. When a duck was shot out of the sky, wounded but not dead, flapping and flopping on the ground, the guy was too cheap to use a shell to dispatch the bird. Instead, he turned the shotgun around and clubbed the bird to death with the butt of the gun. This went on for several years until... you guessed it. The gun went off and finished *him* off. Revenge?

All this is not exactly the same as SMWISICDI,<sup>1</sup> or, "Show Me Where It Says I Can't Do It," but rather more like, "Let Me Show You Why You Had Better NOT Do That." Those of us who are engineers have some responsibility to caution people when what they're proposing to do is REALLY Stupid and Dangerous. OK?

All for now. / Comments invited!  
RAP / Robert A. Pease / Engineer

Address:  
Mail Stop D2597A  
National Semiconductor  
P.O. Box 58090  
Santa Clara, CA 95052-8090

References:

1. Robert A. Pease, "What's All This SMWISICDI Stuff, Anyhow?," *Electronic Design*, May 9, 1991, p. 133.

## SEE BOB'S BEAM BALANCER

Want to see Bob's infamous beam balancer in action? He'll be demonstrating it in person at *Electronic Design's* Wescon booth 1944/1946, Nov. 7-9, at the Moscone Convention Center, San Francisco, Calif. Details of his schedule will be posted at the booth.

## PEASE PORRIDGE



# BOB'S MAILBOX

### Dear Bob:

After reading "What's All This Hassler Stuff, Anyhow?" in the May 15 issue, I reflected back to my earlier design years, about the time I graduated from being a hard-core hobbyist to serious professional. I want to share a story with you which proves that the concept of a hassler device actually goes back a number of years.

About 12 years ago, my wife and I were having dinner in a rather fancy, beautifully landscaped restaurant, located in southern Wisconsin. It was fairly lavishly decorated with palm trees, flowers, Polynesian grass huts, and realistic-looking birds and other wildlife. The atmosphere was quite enjoyable, but was lacking one very important element—sound. The lifeless birds, although aesthetically pleasing, definitely needed more than just pretty colors to give them credibility.

I asked our waiter if I might speak to the manager. He quickly became a tad nervous, assuming I was going to complain about the food or his service. I eased his worry, but at the same time confused him after I told him I intended to breathe some life into those dead animals. The manager, who also happened to be the restaurant owner, soon stopped by our table and asked what the problem was. I said to him, "Your animals are dead!" With a shocked/insulted look on his face, he exclaimed, "Sir, you weren't supposed to notice that!"

Our dialogue soon mellowed, at which time, I offered my talents as an electronics wizard. I told him I could whip up a number of animal-sound devices that could be strategically placed around his man-made jungle to give the effect of a real wildlife environment. The animal sounds were to be triggered when the patrons and/or waiters started talking. He liked the idea. We agreed on a price, and that evening I began designing my first electronic sound-effects generator. I soon realized that by using conventional oscillators, amplifiers, and ana-

log filters, I was unable to create the complex sound of a squawking African parrot. I had to resort to something that was basically designed to make strange noises.

The bulk of my noisemaker circuit was designed around the SN76477 complex sound generator IC. The data sheet for this chip shows a few example circuits that make noises such as bomb blasts, sirens, train whistles, etc., but no animal sounds. After many hours of experimenting with various circuit configurations, I finally ended up with something that made a very convincing parrot squawk. Due to the fact that the sound emitted by such a device is totally subjective, many of the component values had to be selected by trial and error. I later added a VOX circuit, and tailored its response curve to prevent the speaker output from retriggering it.

A few days later, I took my prototype parrot back to the restaurant for a show-and-tell. I placed my little device, mounted within a Radio Shack plastic enclosure, upon the owner's desk and turned it on. I then remained quiet, in anticipation for him to speak. About 30 seconds went by when he began to complain about the device not working. The very syllable of his first word triggered the VOX. The resulting loud, irritating series of squawking sounds completely masked the remainder of his sentence. He was astonished, to say the least. His next move was to write a note on his scribble pad that read "Turn it off!!!" He dared not utter another sound as long as the device was active.

He was so taken by this experience, he immediately wrote me a check for my prototype, and ordered five more exactly like it. His intentions were to keep the prototype in his office, and give the remaining five units to his friend and business associates. As far as I know, they were never used as animal sound makers for his restaurant, but in-

stead they became "hasslers."

**MIKE GRAY**

*Laser Machining Inc.*

*Somerset, Wisc.*

*Hi, Mike, too bad your Hassling Parrot circuit was lost. Mr. Widlar's circuit goes back at least 22 years and also was lost.—RAP*

### Dear Robert:

As a fellow engineer (from the tube days) and follower of your articles, it was great to see the hassler circuit in the May 15 issue. I am also one who tries to reproduce weird circuits for pleasure (?), or at least for my enjoyment. About 25 years ago, I worked for a company that had many of the old manually-programmed patch panels, which someone usually tried to change on the night shift in order to listen to the radio (which was against company rules). I never figured out why, but that was the rule.

After repeatedly having to recheck approximately 1000 wiring points on the patch board nearly every day, I designed a hidden circuit with a hidden on/off switch. It would activate a tape recorder with a hidden remote speaker when anyone pulled the lever to remove the tension on the patch board so they could patch up the radio. (It was the old Amp-type coax patch board.) The speaker had about 100 dB of output and everyone in the building could hear it when activated. The message said, "Some dummy is messing with the patch board. Someone remove him to the outside of the building and beat the living daylight out of him now. Do not allow him to get away."

As you can guess, it got me in a lot of trouble after my boss found out who did it. (He had a good idea who it was.) But, it was worth it, as the patch board was never bothered with for the next four years. Your article brought back sweet memories to me. Keep up the good work. By the way, I'm also diabetic and enjoyed your article on that topic. Good luck and many more years of good writing. I really enjoy reading

# BAL SEAL EMI GASKETS

*Keep the Spring in Your Shielding*



**New gasket designs combine outstanding shielding with long-term service in demanding environments**

Sometimes there is nothing like a fresh-brewed cup of coffee to spring you back to life. Among EMI gaskets, there is nothing like Bal Seal's canted coil spring to keep the shielding through the life of your product.

Many other EMI gaskets lose flexibility due to compression set or thermal cycling. The high deflection and resiliency of each canted-coil on the Bal Seal gasket are able to counteract compression over time. That means consistent shielding effectiveness long after the spring's initial installation.

**"See This Product at Wescon/95, Booth #2455."**

For long term protection from EMI, consider the Bal Seal EMI spring gasket—a tireless performer.

Receive our new catalog on EMI Gaskets by calling our technical sales department at 800-366-1006 / 714-557-5192 or FAX your request to 714-241-0185.



**BAL SEAL ENGINEERING COMPANY, INC.**  
620 West Warner Avenue  
Santa Ana, CA 92707-3398

© 1995 Bal Seal Eng. Co., Inc.

READER SERVICE 97

## DEVICE PROGRAMMERS



\*PC based \$139.95, Parallel port connect \$449.95,  
Stand alone models \$550.00 or \$750.00 gang

\*Read, Pgm and verify 2716 - 8 Megabit EPROM, all models

\*Support for micros, Flash, EPROM, 16 bit, PALs, Mach

(call for specific models support list or download demos via BBS or Internet)

\*30 day money back guarantee, **FREE** software updates

\*Technical support by phone Mon - Fri 8am to 5pm PST

\***Made in the USA**, 1 or 2 year warranty on all parts and labor

\*Easy to use menu driven software, on line "help" full screen editor

\*MACROS, Read and save to disk, Split and set options

\*Internet <ftp://ftp.crl.com/users/ro/needhams>

**FOR MORE INFORMATION CALL**

## NEEDHAM'S ELECTRONICS, INC.

4630 Beloit Drive #20



**(916) 924-8037**

Sacramento, CA 95838

**BBS (916) 924-8094**

(Monday-Friday, 8 am-5 pm PST)

**C.O.D. FAX (916) 924-8065**

READER SERVICE 147

## PEASE PORRIDGE

and learning from your articles. It seems you and I are the only ones left in the world with any common sense.

**LEVI WEIR, JR.**

**Ridge Instrument Co.  
Huntsville, Ala.**

*Yeah, and there's barely enough Common Sense for the two of us, and not much left over for everybody else. Keep 'em honest.—RAP*

**Dear Bob:**

Re: Common Sense in the Sept. 18 issue. I just loved Dale Lee's letter and your response. Why, indeed, is Common Sense so rare?

First, every American should read *The Death of Common Sense* by Philip K. Howard. It gives a lawyer's view: We have laws and rules for every contingency. Instead of making sensible decisions, we just need a large database (what's a gigabyte these days?) and a fast search engine—a no-brainer.

Now, an engineer's view: The demise of slipsticks and multiplication tables did us in. Before I got my Sharp EL-5806 calculator, I had to do things on paper (or in my head) to get the decimal point right. No more. When I gave an Electronics-101 test at the local college, I got values for a car battery resistance that ranged from milliohms to megohms. The response to my queries was always: "Look, I punch this in, and then I punch that in, and here's the answer." I quit.

It's getting worse. New Jersey now has a program for grammar schools called "Education for the 21st Century." Basic idea: Put kindergarten kids on the Internet. Just teach them to push buttons, the computer does the rest. "Wheelchairs for the Brain" is what I call it. Am I glad I won't get far into this 21st century!

**MAX J. SCHINDLER**

**Boonton, N.J.**

*"Wheelchairs for the Brain?" Sigh. I'm afraid you are right.—RAP*

All for now. / Comments invited!  
RAP / Robert A. Pease / Engineer

Address:

Mail Stop D2597A

National Semiconductor

P.O. Box 58090

Santa Clara, CA 95052-8090



# WHAT'S ALL THIS Ball-on-beam Balancing Stuff, ANYHOW?

Several months ago, a reader showed me an application of Fuzzy Logic, which claimed to be excellent. The IEEE Circuits and Devices Magazine (March 1994, pp. 30-35) published an article by Dr. Hua Li and Dr. Yuandong Ji, showing how to balance a ball on a tilting beam. They showed how easy it was to use a little computer (well, actually, a 50-MHz '486-based PC) to get a ball to move to the center of a tilting beam. They claimed that Fuzzy Logic made a much quicker and smoother controller than a trained person. I present a copy of their results in Figure 1: The ball starts out, lurches along, crosses zero five times, and on the sixth try finally gets to stop at the center.

I asked the authors why it took six tries to stop, when any good controller would slow down and stop on the first pass. I asked them why the plot of the beam's tilt looked fishy. That's because sometimes when the beam tilted DOWN, the ball went DOWN. Other times when the beam tilted DOWN, the ball went UP. Sometimes the beam did not tilt at all, and the ball suddenly stopped. The Circuits and Devices Magazine published my questions in the Sept. 1994 issue, and also the authors' comments. Dr. Li's basic reply was to recommend that I ought to read a good book on Fuzzy Logic. And as for their results, Dr. Li could only respond, "I feel my professional practice and achievement respond louder an anything I can write".

After I researched this a little, and found almost no published information on a ball balanced on a beam, I felt challenged to make my own controller. After all, it isn't every day that I can replace a '486 with a simple \$0.85 quad op amp. So when Bob Milne asked what I plan to do for a nice "Analog" column to run in the Special Analog issue in November, I knew this was the right topic.

First I had to design a sensor. There's hardly anything simpler than  $V = I X R$ . I forced 0.50 A down a 3-ft. length of brass model-railroad rail (Zgauge) glued on top of a 1 in. x 1/4-in. X 3-ft. wooden beam (Fig. 2). As the metal ball rolled along on two rails, this voltage on the "hot" rail was transferred to the other rail—just like a wiper on a pot. The I X R drop was about 200 mV, so I fed that into a gain-of-plus-10 preamp to get 2 V full scale. (I mention this because Li and Ji, like most F.L. experts, do not like to mention their sensors.)



**BOB PEASE**  
OBTAINED A  
BSEE FROM MIT  
IN 1961 AND IS  
STAFF SCIENTIST  
AT NATIONAL  
SEMICONDUCTOR  
CORP.,  
SANTA CLARA,  
CALIF.

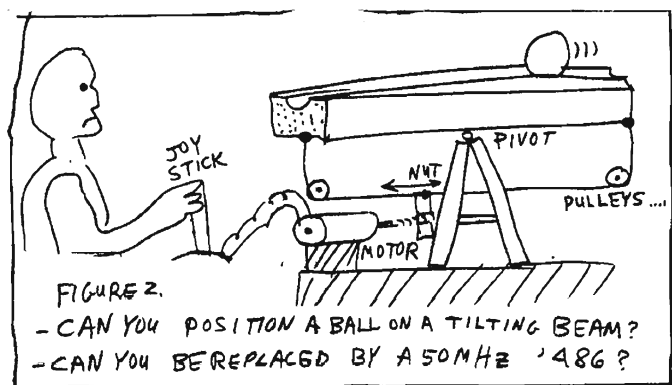
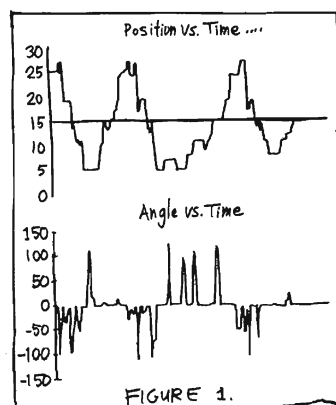

# PEASE PORRIDGE

I bought several ball-bearings, 3/4-in., 7/8-in. and 1 3/32-in. diameter, at Performance Bearings on 3rd Street in San Francisco. I figured there might be some reason the larger balls would work better. Actually there was no difference. Professors Li and Ji did not disclose what they were using for a sensor, but they were apparently shining some kind of LIGHTS onto their ping-pong ball, and detecting the edge of the shadow. That seemed very awkward, as they appeared to have more than one light source. I figured my steel ball would make an excellent pot wiper. And I was right. Note, a ping-pong ball has more air-friction— it's easier to make it stop, but harder to get it going. A ball-bearing has very little friction, so it's a tough test to get it to stop.

To drive the beam and control its tilt, I used a surplus dc motor with a lead-screw. (I could have clamped a piece of threaded rod onto the shaft of any motor, but this was easy.) I drove this motor with an LM3876 power op-amp running on  $\pm 18$  V to get good speed. I used dental-floss (less stretchy than nylon cord) and pulleys to couple the horizontal motion of the lead-screw to the ends of the beam. I mention this because Li and Ji, like most Fuzzy Logic experts, never talk about their power amplifier or output transducer.

The dc path for the control amplifier was easy. I took the voltage from the sensor preamp (A1) and fed it back through R2 to the main control op amp, A2. But, if I just hooked it up this way, it would oscillate like CRAZY, because there are three integrators in the feedback path, not to mention the integrator action of A3 (Fig. 3). After all, the position of the ball is the integral of its velocity—and its velocity will be the integral of the beam's tilt! The dc gain will be INFINITE, and any roll-off of the gain with frequency will surely be at 18 dB per octave. Very bad phase shifts! This loop is sure to oscillate if I don't intervene and put in some special tricks to make this loop stable.

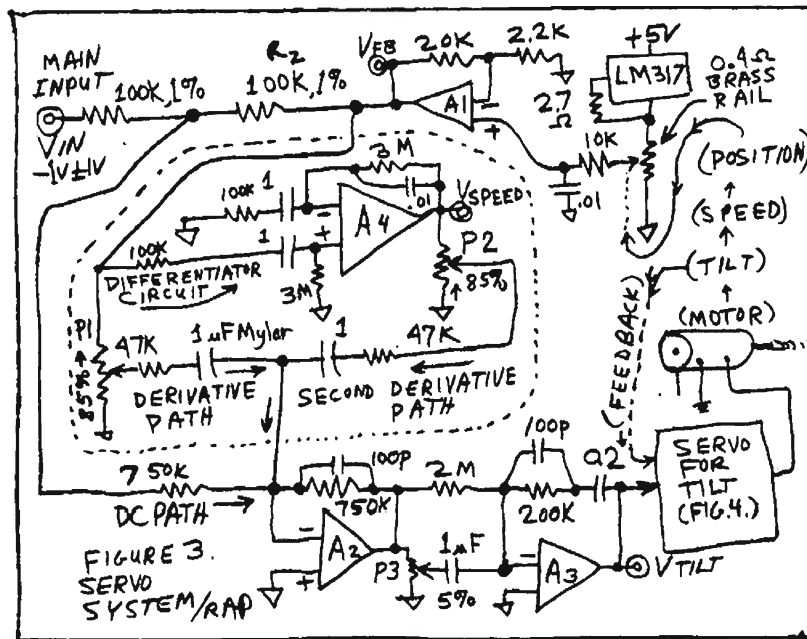

I knew I could not use just a simple PID (Proportional, Integral, Derivative) controller of the type I discussed in a recent column (June 26, 1995), because when there are two or three integrators in the loop, a simple PID controller can't control the loop. But my plan does look like a PID with the addition of extra circuits (differentiators).

First, I put the motor inside a feedback loop, so the motor's lag would be effectively decreased to a negligible amount (Fig. 4). Then we set up a pot to sense the tilt of the beam so we could close the loop. And then we built the tilt-servo. It worked the first time, but I had to make a couple changes:

# PEASE PORRIDGE

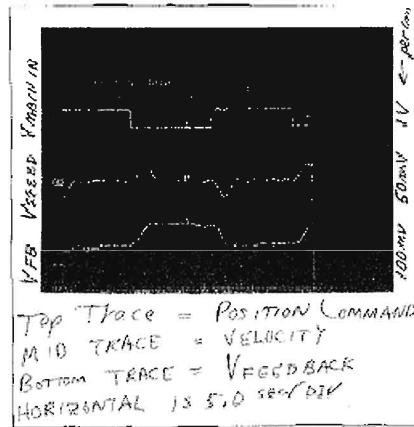
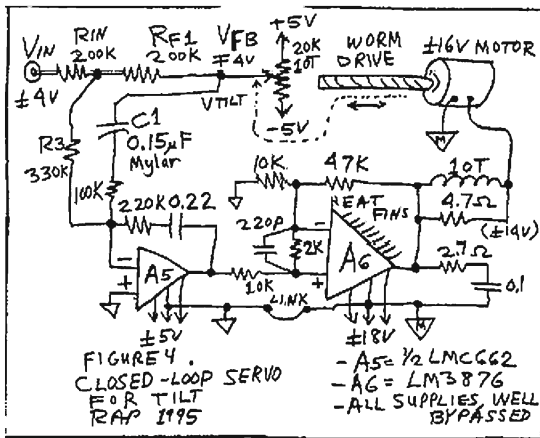

1. I had to add a heat sink for the power amplifier—the poor little amplifier kept going into thermal shutdown because I forgot to provide one!
2. I had to decrease one capacitor's value (C1, cut 1 uF to 0.15 uF) since it was causing a long tail in settling. (If I had put a pot in there, I could have just turned the knob.)

Then we added a joystick (just a pot with a lever) so we could control the beam's tilt manually. Making the ball move over from one spot to another spot is NOT a really easy loop to control by hand. It requires thought and planning. It's fun to try. And it's still possible to have it run smoother and faster than Li's Fuzzy Controller.

Then we built the main loop, with the dc path and a couple of differentiators added in (Fig. 3, again). These signals help us anticipate that the ball is approaching the right place, to help the controller slow it down and stop. It's just like the Differentiator effect in a PID loop, but we have a Derivative and a Second Derivative. You might call this a PID2 Controller.

We fired it up and it worked pretty well the first time, with most of the pots set at maximum damping. But it didn't damp out too well until I fixed two more items:

3. I had to cut down some friction in the pulleys.
4. One amplifier was wired wrong in the differentiator.

After that, it ran pretty well. The ball moves smoothly and only overshoots a few percent. It rarely lurches or jitters. I can use it to position the ball at any point on the beam. As shown in the scope photo on the next page, the voltage that represents the ball position settles smoothly—just as the ball does.

I still don't know why my scheme is so slow; I want to figure out how to make it faster. There are several ideas I'd like to try out, and I've had several suggestions on making it servo and settle much faster. Maybe the integrator in the main servo loop is adding too much dc gain. I may be able to decrease friction with a dither, or a preload.

When I do get this working really well, I'll send a videotape to Dr. Li and Dr. Ji - just to show them how a beam balancer can work well. They claimed they got their best results because they didn't use any models. Mine runs well because I was able to use simple models: a rolling ball is a double integrator. They claimed their Fuzzy Logic was able to triumph over the nonlinearities of a tilted beam. Well, the approximation that sine of tilt angle = tilt is only nonlinear by a few percent. They still can't servo the ball to any place on the beam as fast as my PID2 controller.

If I get some time, I may be able to try out a deterministic solution: Bang the motor ON for a while, then when the ball has moved about half way, bang the motor to tilt the beam the other way. When the ball is nearly at its goal, then I'll servo the beam to be flat. This will require a bunch of tricky circuits, but if you're really in a hurry, this is surely the right way to do it.

P.S. Thanks for Jay Friedman's and Kevin Thompson's help.

PPS. In case the position sensor got flaky, I was prepared to buy a tube of carbon-loaded lubricant that's made by Planned Products of Santa Cruz. But we never had any trouble with that, so there was no need to buy that stuff. It's a little pricey, about \$13 at Fry's, but it's nice to know it's there.



# PEASE PORRIDGE

Originally published in Electronic Design, November 20, 1995

RAP's 1997 comments: My BOBB keeps on plugging. When I published this in '95, I had gotten the settling time down to 8 seconds. I added an R-C network from  $-V_{in}$  to the first summing point, and it didn't help. I added it again later, and it worked just fine, and helped me get the settling time down to 4 seconds, and 3.2 on a good day. How am I going to get it down to less than 2 seconds? More on this, later. I have seen a couple recent technical reports on BOBB using Fuzzy Logic. They are not bad at all. They seem rational. They are not hyped. And, surprisingly, they make no reference to the seminal Ji/Li article. More on this later.

Here I'll list three References from the magazine: IEEE Transactions on Fuzzy Systems. (Isn't it funny that dozens of F.L. enthusiasts gather there to say good things about F.L., and I'm the only protection you have from them?)

1. "Designing Fuzzy Controllers from a Variable Structures Standpoint," J. Glower and J. Munighan, North Dakota State University, Fargo, N. Dak. pp. 138-144, Feb. 1997. They simulated a response of about 4 seconds, but had not built a model at the time of publication. Honest, realistic work. I'll add more comments later. They agree that adding P plus D terms before they are sent into the F.L. controller can improve and simplify the system, as I proposed above in my PID column.
2. "How to Design a Discrete Supervisory Controller for Real-Time Fuzzy Control Systems," N. Muskinja et al., University of Maribor, Slovenia, May 1997, pages 161- 166. They show some curves with some not-entirely linear results, with settling in the range 4 to 8 seconds. They don't explain a lot about their analog-digital interface. But they use pulleys like I do.
3. "Adaptive Fuzzy Control: Experimental and Comparative Analyses." R. Ordonez et al., Ohio State University, May 1997, pp. 167-188. They show comparisons between computer simulations and the systems they BUILT. Very honest guys. They actually wrote about their sensors and their interfaces. Very honest. They got results in the 4 to 6 second range. More on this, later.-rap

**PEASE  
PORRIDGE**



## BOB'S MAILBOX

**Dear Mr. Pease:**

Thank you for responding (via mail) to my letter that appeared in the April 28 issue about Design Quality. In your reply, you asked for real-world examples rather than platitudes. I will attempt to pass judgment on a few products that have Design Quality, and a few that do not. A listing of products that lack Design Quality, and why, also is useful and may be more instructive.

The LM117 has Design Quality, and so do the LM301 and the  $\mu$ A741. Most Tektronix analog oscilloscopes have it. Fortifications *designed* by Leonardo Da Vinci have it. The circular slide rule also is a good example.

The LF157 lacks Design Quality—despite being a very successful product—because of the output phase reversal. As a power-supply design engineer, I have yet to find a digital scope that does what a good analog one will do.

Other products that lack Design Quality include: Fortifications *built* by Leonardo Da Vinci. He never got the foundations right and they fell apart. If someone else built them, they lasted quite long. Egypt's Aswan High Dam may be quite well done as a dam, but it is grossly ill-conceived as a project.

Windows for the PC, despite its neat features and capabilities, lacks Design Quality. At best, it is a hodge-podge of features and capabilities that lacks a clear concept of what it is supposed to be. There is little hope that Windows 95 will be any better—just different.

Here are the platitudes again in a gross attempt to define Design Quality:

*Conceptual integrity:* The design is as simple as necessary and is an elegant solution to the problem. It's conceived by no more than four minds.

*Abnormal conditions:* The design responds in a controlled and predictable manner to abnormal conditions.

*Standard performance:* The design meets all standard application requirements, not just the specification.

A walk through the design of a power supply to run from an aircraft 28-V

power bus will be instructive since aircraft power is unusually well specified. This example shows the application of Design Quality to the design process. Its output will be 12 V dc at 1.0 A. At first glance, this would seem to be a perfect candidate for a simple buck converter to drop the 28 V down to 12 V. The range of the 28-V bus is generally 22 V to 32 V, so this will work. The regulation can easily be better than 1%, and a simple single-chip-type switching regulator will work fine. I have seen this type of circuit implemented on aircraft and almost designed one myself. This design lacks Design Quality because it does not consider the application and does not handle abnormal conditions.

Aircraft power buses can go below 7 V during engine start in cold weather. Does the supply shut down during these conditions? Is the equipment it is powering supposed to stay active during an engine start? This condition is usually not mentioned in the specification. It must be inferred from knowledge of the equipment's range of application and knowledge of the aircraft power system.

The output of a simple buck regulator is not isolated from the 28-V bus, which has two implications. The first is that failure of the switching transistor will result in the destruction of the equipment since the output voltage will quickly rise to meet the 28-V bus. The second is that ground loops are possible between the power-bus ground return and the signal ground returns, because they are connected together inside the box. Power flow through the signal grounds will add noise to the signal inputs. An isolated power-converter topology, such as a flyback or a forward converter, will reduce this problem greatly.

The input power bus on an aircraft is generally specified with a surge voltage that is more than double the normal operating voltage. An 80-V surge for 100 ms is standard on many aircraft. This will cause destruction of a standard buck regulator IC. This condition does not occur very often since it is

caused by failure of the generators on the engines. When it does occur, what should the equipment do? Some equipment can shut down for 100 ms to protect the power supply. Some can't. An aircraft on instrument approach to Tahiti lost the generator in one engine. This caused the attitude and heading instruments on board to go off line—they can't be restarted in the air. Had the weather not been good, they may have crashed.

The aircraft power bus is subject to spikes and high-intensity RF (HIRF) fields. The spikes may be generated by other equipment on the power bus (motors and relays), or by induction from lightning strikes flowing through the hull. The spikes must be filtered or clamped. Some of the spikes have a high-enough energy that they will saturate the input filter inductors. Laminated cores often work better than ferrites for input filter inductors. That's because when they saturate, the laminations become resistive due to the eddy currents in them, which presents a greater impedance than a saturated ferrite. The laminations also will have a higher impedance to the HIRF fields. Clamps used to protect the power supply must have a sufficiently high energy rating to absorb the spike.

The input filter is necessary to reduce the noise generated by the switching supply. A four-pole filter has minimum size and weight for a given attenuation at the switching frequency. The input power bus is specified with several volts of noise at low frequencies that comes from the brushes in the generators. The noise is generally lower in frequency than the cutoff of the input filter. The control loop of the switching regulator must be wider than the cutoff of the input filter to maintain power-line rejection with minimum size and weight. Techniques such as current-mode control or voltage feedforward also are useful to increase the power-line rejection. The input filter will need common-mode filtering as well as normal-mode filtering if the output is iso-

# "YOUR FREE CATALOG KNOCKED MY SOCKS OFF"

We get that sort of comment all the time. People are impressed that our free Consumer Information Catalog lists so many free and low-cost government booklets. There are more than 200 in all, containing a wealth of valuable information.

They tell you how to make money, how to save money and how to invest it wisely. They tell you about federal benefits, housing and learning activities for children. They fill you in on nutrition, jobs, health and much, much more.

Our free Catalog will very likely impress you, too. But first you have to get it. Just send your name and address to:

**Consumer Information Center  
Department KO  
Pueblo, Colorado 81009**

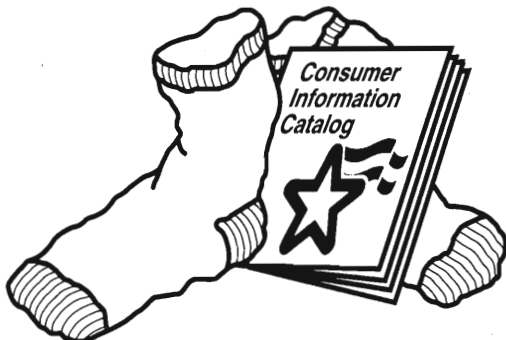

A public service of this publication and the Consumer Information Center of the U. S. General Services Administration

## PEASE PORRIDGE

lated. The rejection of the filter must extend beyond the rise-time cutoff of the switching transistor. This often extends from below 5 kHz to above 50 MHz. The layout of the filter is critical to achieving extended rejection. The filter must be damped to prevent amplification of the line noise and it must not cause an input filter oscillation condition when connected to the power supply. Capacitors in the filter must have a sufficiently high voltage rating to prevent damage during a spike input if the inductors saturate.

A design considering all these conditions is a lot more complex than a simple buck regulator. Done well, it will have Design Quality. It will have conceptual integrity. All of the pieces work well together and the system performance meets the specifications. The design handles abnormal conditions in very predictable ways. It shuts down at low input voltages, provides excellent attenuation of line noise, has low EMI emissions and susceptibility, and handles spikes, surges, and HIRF without degradation of the output. It is also manufacturable at reasonable cost and requires little, if any, maintenance.

It takes a long time to learn Design Quality and its broad frame of reference that includes the entire application, inputs and outputs, and the manufacturing and maintenance processes.

**PHILIP C. TODD P.E.**

**Power Innovations  
Long Beach, Ca.**

*Yeah, there are several good definitions of a "good" design, or an "elegant" design, or a "high-quality" design, and most are similar to your descriptions. However, I think an aircraft power bus is NOT an elegant system; it is a real-world system that is very messy, and any power supply that runs from it must be designed, as you correctly say, VERY carefully, so as not to goof up in any of those horrible worst cases you described.—RAP*

All for now. / Comments invited!  
RAP / Robert A. Pease / Engineer

Address:  
Mail Stop D2597A  
National Semiconductor  
P.O. Box 58090  
Santa Clara, CA 95052-8090



# Fuzzy-Logic Tools On Tap for IC Wafers

Up-and-coming technique emerges as a clear choice  
for quality control checks in wafer manufacturing

by Hua Li and Yuandong Ji

**F**uzzy logic, introduced in 1965 [1], was originally developed as a method for implementing decision-making functions with *if-then* rules. Now, it is becoming more widely recognized as a practical tool for dealing with the topic of uncertainty and systems that are poorly understood from the mathematical standpoint. During the past several years, the interests in applying fuzzy logic to control, signal processing, and manufacturing has been experiencing rapid growth. Examples include aircraft flight control [2], accessing equipment reliability [3], controlling chemical reactors and processes [4], tracking 2D motion [5], and controlling typically nonlinear systems, such as backing up a truck and trailer [6].

Working with the semiconductor industry, we have recently developed techniques based on fuzzy logic for automated visual inspection and control applications. In this article, we will briefly introduce the concept of fuzzy logic, then describe how fuzzy logic can be used to detect dimple defects on polished wafer surfaces. Finally, we will discuss our in-house built demonstration system.

## Fuzzy Set Theory

### Basic Concepts

A fuzzy set,  $A$ , of a universe,  $U$ , consists of two critical components: (1) a membership functions  $\mu_A : U \rightarrow [0,1]$ , which associates

with each element  $x$  of  $U$  a membership in the interval  $[0,1]$ ; and (2) the support of the fuzzy set, which is a set of element  $x$ . The value of the membership function  $\mu_A(x)$  represents the grade of  $x$  in  $A$ . A larger membership value of  $x$  indicates a closer belonging. For example, let  $A$  be a set of young engineers, where  $x_1 = 25$  and  $x_2 = 35$  are the ages of two such engineers, and where the membership function  $\mu_A(x_1) = 0.8$ ,  $\mu_A(x_2) = 0.6$  indicate that the first engineer fits much closer into the group of young engineers.

A fuzzy set can be represented as follows:

$$A = \int_U \mu_A(y)/y \quad (1)$$

where the integral stands for the union.

Some most widely adopted basic operations on fuzzy sets include the min-max model [1]:

$$A \cap B = \int_U \min(\mu_A(x), \mu_B(x))/x \quad (2)$$

$$A \cup B = \int_U \max(\mu_A(x), \mu_B(x))/x \quad (3)$$

where both  $A$  and  $B$  are fuzzy sets.

The process of designing fuzzy logic application usually involves five steps: (1) formulating the problem and selecting vari-

ables as control signals and the signals for measuring the system performance; (2) deriving inference rules; (3) designing fuzzy membership functions for each variable; (4) performing fuzzy inference based on the inference rules; (5) obtaining a control signal, performing "defuzzification" to derive an actual control action.

### Fuzzy Reasoning

Fuzzy reasoning is based on the compositional rules of inference. There is more than one way of generating fuzzy reasoning rules. Generally, their design requires significant insight and understanding of the problem. Very often, the rules can be derived heuristically rather than from closed-form mathematical formulae. Hence, it is difficult to automate the design process. Nevertheless, the rules should be derived (1) to reflect a human expert's experience and knowledge; (2) to have sound analytical background; and (3) to exhibit some learning and generalization capability. Consider the following example:

Rule 1: If  $x_1$  is  $A_{11}$  and  $x_2$  is  $A_{12}$  then  $y$  is  $B_1$

Rule 2: If  $x_1$  is  $A_{21}$  and  $x_2$  is  $A_{22}$  then  $y$  is  $B_2$

The truth values of the premises are given by  $w_1 = \min(\mu_{A_{11}}(x_1), \mu_{A_{12}}(x_2))$ ,  $w_2 = \min(\mu_{A_{21}}(x_1), \mu_{A_{22}}(x_2))$ .

The actual control signal as the inference result is calculated by

$$y = \frac{\sum_{i=1}^2 w_i y_i}{\sum_{i=1}^2 w_i} \quad (4)$$

where  $y_1 = \mu_{B1-I(w1)}$ , and  $y_2 = \mu_{B2-I(w2)}$ . This process is illustrated in Fig. 1.

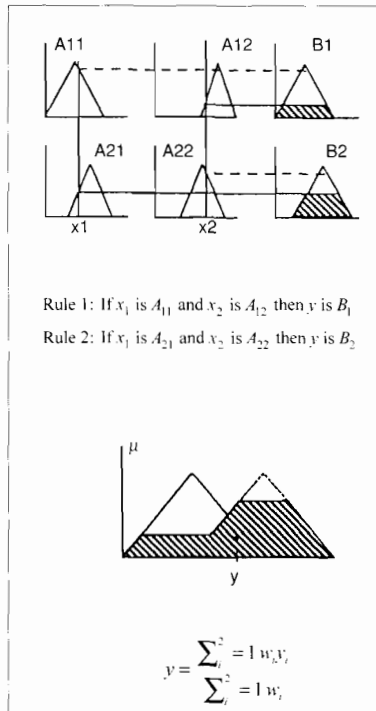

1. Fuzzy inference and a defuzzification process.

### Dimple Defect Detection

As mentioned previously, we have applied fuzzy logic to automated visual inspection of polished wafer surfaces, in particular, the detection of dimple defects. The inspection of polished-wafer surfaces has traditionally been done by human operators. The accuracy of human inspection declines with dull, endlessly routine jobs and no human operator has achieved better than 87 percent effectiveness on a shift basis [7].

Dimples are common surface defects of polished wafers. They appear as circular-shaped bright spots, which usually vary in size and location. They may also have ir-

regular boundaries and co-exist with other image features. The boundary between circular shape and non-circular shape is gradual. Humans are able to classify distorted objects based on partial information. For example, the notion of an object that "well belongs to," or "somewhat belongs to" a given class are used in daily life to describe the degree of "fitness." However, it is difficult to use conventional mathematics to describe this notion.

The semiconductor industry addresses the problem by using computer vision. These include the inspection of printed circuit boards [8]. Many different techniques have been developed, but an algorithm that possesses a *distortion-invariant* property has yet to be found. Our objective was to develop an algorithm to detect dimple defects regardless of their sizes, positions, orientations, and shape distortions. Our goal was to find a means by which we could (1) efficiently characterize the dimples; (2) make the identification process not only scale-, position- and orientation-invariant, but also distortion-invariant. Our system consists of two major processing stages: pre-processing and identification.

### Preprocessing

Given a wafer image  $I(x, y)$ , its edge map  $E(x, y)$  is defined by two-dimensional convolution as  $E(x, y) = I(x, y) \otimes S(x, y)$ , where  $S(x, y)$  is a nonlinear edge detector.  $E(x, y)$  is further binarized to obtain  $B(x, y)$  by simple thresholding. Let  $b_i(x, y)$ ,  $i = 1, 2, \dots, n$ , represent individual binary pattern. Thus, the binary image  $B(x, y)$  is a collection of binary patterns,  $B(x, y) = \{b_i(x, y), i = 1, 2, \dots, n\}$ . A  $b_i(x, y)$  is a potential defect if its size falls in the range of  $[T_1, T_2]$ .

### Defining Defects

It is well observed that a simple equation

$$(x-x_0)^2 + (y-y_0)^2 = r^2, x, y \in R \quad (5)$$

cannot be directly utilized to characterize a digital circle for a finite resolution of a digital display device. To cope with this, we employ Bresenham's algorithm, which is based on the concept of a digital circle. Close examination of two different size Bresenham circles (Fig. 2a) reveals that the finite resolution of a circle alters its appearance. In the extreme case, a small circle degrades to a symmetric pattern that may be perceived as a diamond-shape object (Fig. 2b). In addition, dimples are not

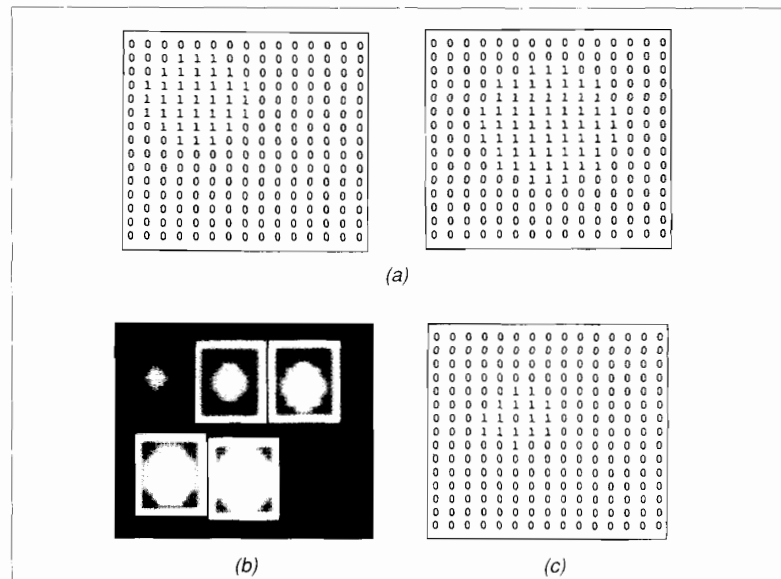

2. Two of Bresenham's digital circles (a). Note how the finite resolution affects the appearance of the circle. (b) The display of five Bresenham circles. Note that the finite resolution of the display device degrades the smallest circle to a diamond-shape symmetric pattern. (c) A dimple defect taken from a real image.

perfect digital circles. It may have irregular boundaries. Figure 2c shows a dimple defect taken from actual experimental data.

Using a fuzzy membership function, we can describe the pattern's closeness to a circle. Our algorithm involves three stages. First, we reject all badly-asymmetric patterns. Then, among the remaining patterns, we use fuzzy membership to define the "acceptance" of distorted circular-shaped dimples. Finally, decision-making based on the membership of "acceptance" is performed to identify dimple defects.

*Selecting Symmetric and Circular Patterns*  
Discriminating badly-asymmetric patterns from symmetric or slightly-asymmetric patterns is achieved in two steps. In the first step, a symmetric pattern is selected by utilizing moment functions,

$$m_{p,q} = \iint x^p y^q f(x,y) dx dy \quad (6)$$

of order  $p + q$ . Now,  $m_{pq} = 0$  when  $x^p y^q$  is odd and  $f(x, y)$  is symmetric. This property can be extended to central moments  $\mu_i$  and moment invariants  $\phi_i$  [9].

We further identify circular patterns from the symmetric patterns by defining four parameters,  $\alpha, \beta, \gamma,$  and  $\delta$ , where  $\alpha = A_p / A_w, 0 < \alpha < 1$ , and where  $A_p$  is the size (area) of the pattern and  $A_w$  is the size of the window, which circumscribes the given pattern (Fig. 3). In addition,  $\beta = P_p / P_w, 0 < \beta \leq 1$ , where  $P_p$  is the perimeter of the pattern and  $P_w$  is the perimeter of the window. Also,  $\gamma = (y_{\max} - y_{\min}) / (x_{\max} - x_{\min}), \gamma > 0$ , where  $(x_{\min}, y_{\min}), (x_{\max}, y_{\max})$  are the upper left corner and lower right corner of the given pattern. Finally,  $\delta = P_p^2 / A_p, \delta > 0$ .

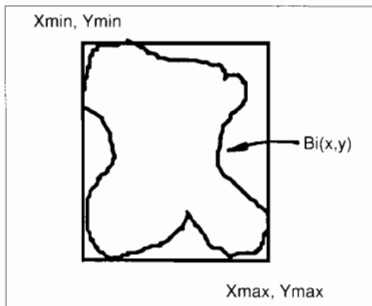

3. A given pattern  $b(x,y)$ , and the window circumscribing it.

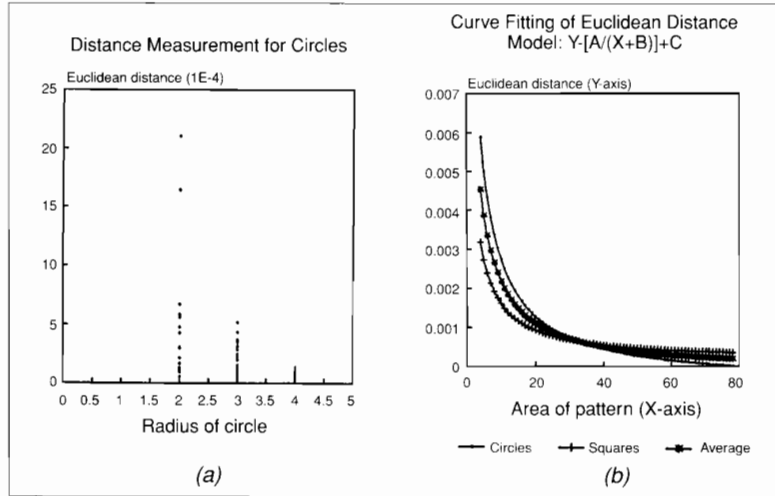

4. The experimental data (a) illustrate the set of ADCP (acceptable distorted circular patterns), denoted by  $X^p$ . The critical measurement is obtained from this experiment to generate decision-making function. (b) A non-linear fitting is performed to generate the decision-making function. Below the function is the region that accepts a pattern known as a "dimple." A membership function can be generated to move the function up and down to cope with symmetric distortion and asymmetric distortion.

For an ideal circle regardless of its size and position, we should have a cluster  $(\pi/4, \pi/4, 1, 4\pi)$  in the  $(\alpha, \beta, \gamma, \delta)$  space.

#### Handling Distortions

The distortion of digital circles mainly comes from two sources: the limitations of finite resolution of a digital circle when its size is too small; and the random variations of its boundaries.

In the first regard, a method can be developed to handle the effect of size distortion. That is, to use measures in the  $(\alpha, \beta, \gamma, \delta)$  space to characterize distortion. We have previously determined that the distorted patterns have their parameters defined in the following range,  $1/2 \leq \alpha \leq 1, 1/2^{0.5} \leq \beta \leq 1, \gamma = 1$ , and  $\delta = 16$ . When it comes to considering distortion from random variations of the dimple boundaries, a more sophisticated algorithm is needed.

#### Distortion-Invariant Operator

The development of distortion-invariant operator includes defining the "degree" of acceptable distortion and designing a decision-making algorithm that will discriminate any "acceptable" distorted circular patterns (ADCPs) from others. ADCPs may be obtained by adding or deleting some portion or portions of circular patterns

which define the "acceptability" as that for which (1) slightly asymmetric patterns are allowed, (2) different positions and sizes are possible.

Generally speaking, small size symmetric patterns can be treated as ADCPs due to the limitation of the display device's finite resolution. However, as the size of a non-circular symmetric pattern grows, the "acceptability" of the pattern degrades. There is a threshold beyond which symmetric patterns are no longer acceptable. Experiments are performed to generate two sets of functions to separate "acceptable" from "non-acceptable" patterns for both symmetric and asymmetric classes (Fig. 4). Using nonlinear interpolation, two functions,  $f_1(b_i(x, y))$  and  $f_2(b_i(x, y))$ , are obtained.

Each of these functions partitions the pattern space into two subspaces. When  $f_j(b_i(x, y)) \leq 0, j = 1, 2$ , the patterns are acceptable. By assigning different offsets to  $f_j(b_i(x, y))$ , we change the threshold of acceptability. Using fuzzy membership, we can control the threshold whose fuzzy membership function,  $\mu_{\theta}(Y)$ , describes the closeness of a pattern to a "perfect" dimple. The membership function ranges from 1 for a "perfect" dimple to a threshold  $T\alpha$  for barely "acceptable" dimples. The value in between indicates the acceptable detection result.



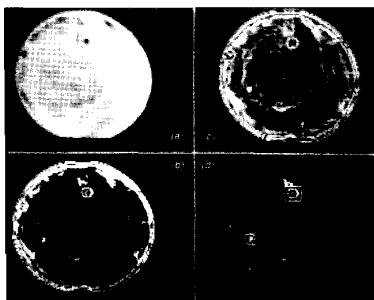

5. The process result: (a) is the original image, (b) is the convolution result by using Sobel operator, (c) is the binarized image of (b), and (d) is the image after removing all noise and non-potential candidates. The fuzzy decision-making algorithm assigns markers around the detected dimples.

The decision-making algorithm based on the membership value is developed as:

$$b_i(x,y) = \begin{cases} ADCP, & \text{if } \mu_a(Y) \geq T_a \\ \text{Reject}, & \text{otherwise} \end{cases}$$

#### Experimental Results

The algorithms were implemented on a 386 machine. Test pattern images were used to verify the algorithms. Then an 8-bit wafer image with 256 x 240 resolution was used as input data. Resolution reduction of the input image was first performed before the preprocessing. Fuzzy membership functions were evaluated according to the algorithm given in the previous section. Fuzzy decision-making was performed by using a properly chosen threshold  $T_a$ . The experimental results confirm our design. Figure 5 shows a processed wafer image. As one can see, the dimples are detected.

#### Beam-Balancing System

In the semiconductor manufacturing industry, many systems are highly dynamic, nonlinear, and constantly under random disturbances. These includes gas distribution systems, furnaces, and so on. Closed-loop control, adaptive and model-based control techniques have been used quite successfully for controlling certain processes, but not that effective for dealing with the processes having high nonlinearity and random disturbances. We recently developed a fuzzy control demonstration system, called a beam-balancing system [10], to demonstrate fuzzy control.

The control objective is to balance the beam and bring a ping-pong ball to the center of a beam (Fig. 6). The control algorithm is based on the knowledge of the system parameters as given in the vector form  $V = (J, m, g, r)$ , where  $J$  is the moment of inertia of the ball,  $r$  is the radius of the ball,  $m$  is the mass of the ball, and  $g$  is the gravity constant. The mathematical formulation of the control objective and control algorithm can be formidable in the case where the system parameters are unknown or changing as functions of time, or high random disturbances exist. In order to cope with these factors for real-time control, we developed a fuzzy logic controller.

#### Methodology

The controller performs three major functions. It (a) determines the types of sensory data and performs the "fuzzification" of these inputs; (b) selects fuzzy inference

rules for reasoning; and (c) computes the control action.

In fuzzification, the three inputs selected are displacement,  $d(t_i)$ , (position of the ball); a beam angle,  $\alpha_i$ , and the velocity of the ball,  $I(t_i)$ . Here,  $I(t_i) = \{d(t_i) - d(t_j)\}/\tau$ , and  $\tau$  is a unit time interval. The control action,  $C$  is a set of control sequence  $C(t_i)$  for  $i = 0, 1, \dots, n$ .

We first quantize each of these parameters into six levels and use linguistic variables, positive (or negative) large  $\pm L$ , positive (or negative) median  $\pm M$ , and positive (or negative) small  $\pm S$ , to describe each level. Hence, we have

$$D = \{ D_{+L}, D_{+M}, D_{+S} \}$$

$$\alpha = \{ \alpha_{+L}, \alpha_{+M}, \alpha_{+S} \}$$

$$I = \{ I_{+L}, I_{+M}, I_{+S} \}$$

$$C = \{ C_{+L}, C_{+M}, C_{+S} \}$$

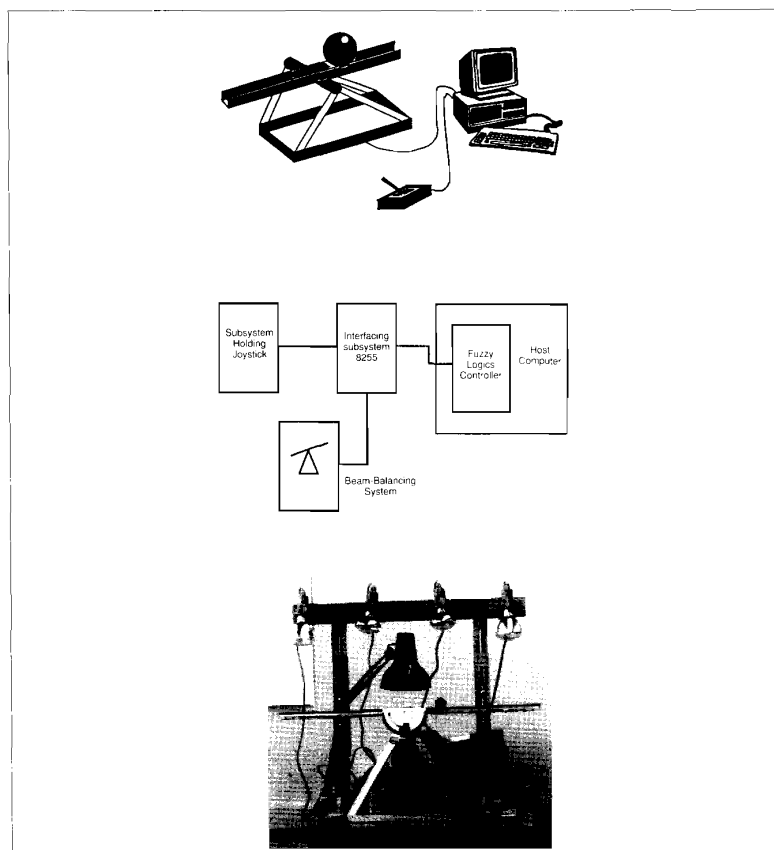

6. In-house beam balancing system and its block diagram.

Control Rules for the Beam Balancing System					
If angle is +SMALL					
+LARGE	+LARGE	+MEDIUM	-SMALL	-SMALL	-MEDIUM
+LARGE	+MEDIUM	+MEDIUM	-SMALL	-SMALL	-MEDIUM
+LARGE	+MEDIUM	+SMALL	-SMALL	-MEDIUM	-LARGE
+LARGE	+MEDIUM	+SMALL	-SMALL	-MEDIUM	-LARGE
+SMALL	+SMALL	-SMALL	-MEDIUM	-LARGE	-LARGE
+SMALL	-SMALL	-SMALL	-MEDIUM	-LARGE	-LARGE
If angle is +MEDIUM					
+LARGE	+MEDIUM	+SMALL	-SMALL	-MEDIUM	-LARGE
+LARGE	+MEDIUM	+SMALL	-SMALL	-MEDIUM	-LARGE
+LARGE	+MEDIUM	+SMALL	-SMALL	-MEDIUM	-LARGE
SMALL	-SMALL	-MEDIUM	-MEDIUM	-LARGE	-LARGE
-MEDIUM	-MEDIUM	-MEDIUM	-MEDIUM	-LARGE	-LARGE
-MEDIUM	-MEDIUM	-MEDIUM	-LARGE	-LARGE	-LARGE
If angle is +LARGE					
+LARGE	+LARGE	+MEDIUM	-SMALL	-MEDIUM	-LARGE
+LARGE	+MEDIUM	+SMALL	-SMALL	-MEDIUM	-LARGE
+MEDIUM	+SMALL	-SMALL	-MEDIUM	-LARGE	-LARGE
+SMALL	-SMALL	-MEDIUM	-MEDIUM	-LARGE	-LARGE
-MEDIUM	-MEDIUM	-LARGE	-LARGE	-LARGE	-LARGE
-LARGE	-LARGE	-LARGE	-LARGE	-LARGE	-LARGE

Then fuzzy membership functions for each linguistic variable are defined. Membership functions  $\mu_{D+L}$ ,  $\mu_{D+M}$  and  $\mu_{D+S}$  are shown in Fig. 7 for D+L, D+M, and D+S, respectively. The membership functions for the negative part are the mirror images of these functions.

As for fuzzy inference rules, we perform  $D \times \alpha \times I$  to cover all the possible combinations of the inputs. Using the compositional rule of inference [11] and a connective "AND" operation, we have derived 216 inference rules. The list of some rules are given in Table 1. The membership value for

each control action for each inference rule is determined by the  $\min$  operation, as  $\mu_{C+L} = \min(\mu_{D+L}, \mu_{\alpha+L}, \mu_{I+L})$  for rule 1, etc.

Computing the control signal is done through linguistic variables for each set of input signal from  $D \times \alpha \times I$ . Then defuzzification is performed by the following center of gravity algorithm:

$$C(t_{i+1}) = \frac{\sum_{i=1}^{216} w_i C(t_i)}{\sum_{i=1}^{216} w_i}$$

where  $w_i$  is the corresponding membership value.

#### Experiments

The prototyping system was built in-house. It consists of a host microprocessor Intel 80486, a joystick that allows human intervention so that the comparison between human control and fuzzy control can be made, and a fuzzy logic control program stored in the host computer. The algorithm for fuzzy-

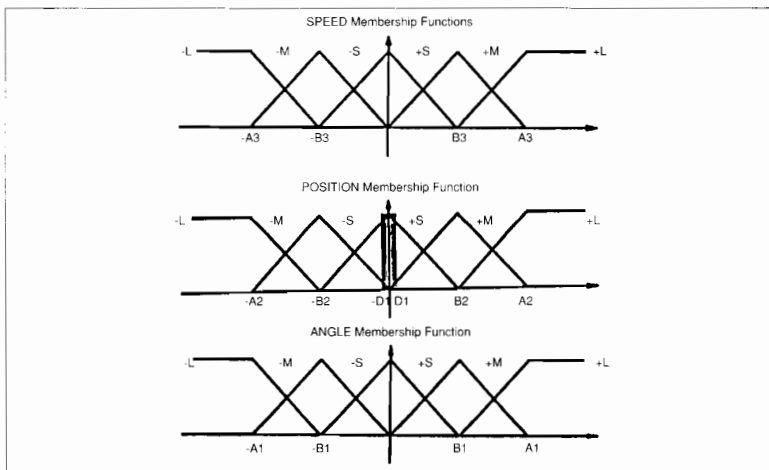

7. Membership functions for  $D+L$ ,  $D+M$ , and  $D+S$ , respectively.

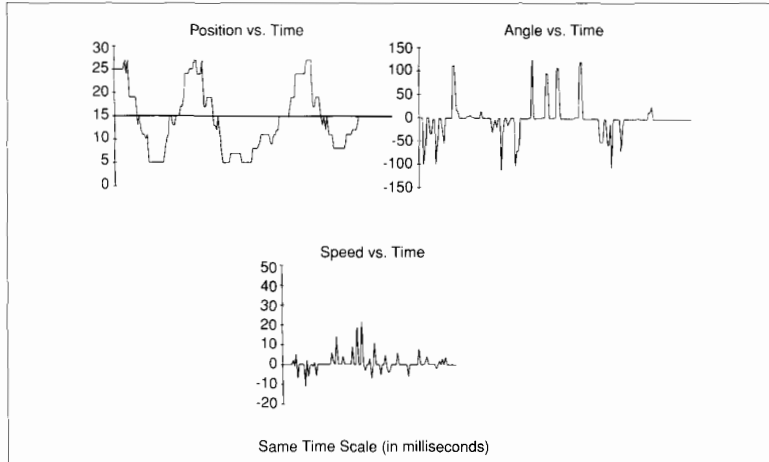

8. Response of the beam-balancing system. Note that the position and angle are converging, which essentially ensures the system is stable.

fication, fuzzy reasoning, and computation of the control signal were written in C, and the driver program that directly controls the Intel's 8255 I/O chip was written in Microsoft Assembly Language.

Our prototyping system can be operated in two different modes, human operator control mode via a joystick, or fuzzy logic control mode through the host microprocessor. The human control takes quite practice especially when the angle is beyond 10 degree. The average player takes quite a few trials before being able to balance the system and bring the ball to the center of the beam. The computer control mode works under a 50 MHz 486 machine. It calculates each control action, which includes fuzzification, reasoning, and defuzzification. The beam is balanced faster with less number of control actions and less overshoot (Fig. 8).

### Conclusion

In this tutorial article, we briefly described the concept of fuzzy logic, and developed a technique for detecting dimple defects for automatic visual inspection of polished wafer surfaces. Our fuzzy logic controller bal-

ances a beam in real-time without an explicit closed-form mathematical formulation. This in-house prototype can be operated automatically through the execution of a fuzzy control algorithm. Unlike most of the conventional and optimal control algorithms, this controller requires no system dynamics, and it is characterized by its simplicity and easy implementation. It is a convenient tool for automating operator controlled processes, although theoretical results concerning the system's stability and robustness are still not available and cannot be easily obtained.

### Acknowledgment

The authors would like to thank the reviewers for their comments. In particular, we thank graduate students Jen-Chung Lin, who assisted the wafer inspection project; and Nowell Godfrey, for his work in prototyping the beam-balancing system. We are also grateful to William Marcy for his expertise. A special thanks also goes to FSI International for their support to the fuzzy logic controller project.

**CD**

Hua Li is an assistant professor in the Computer Science Department, College of Engineering, Texas Tech University. His current research interests include vision computing, neural networks, and their implementation in VLSI. Yuandong Ji is a visiting assistant professor at the Department of Systems Engineering at Case Western Reserve University.

### References

1. L. A. Zadeh, "Fuzzy Sets," *Information Control*, **8**, pp. 338-353, 1965.
2. S. Chiu, S. Chand, D. Moore and A. Chaudhury, "Fuzzy Logic for Control of Row and Moment for a Flexible Wiring Aircraft," *IEEE Control Systems Magazine*, June 1991, pp. 42-48.
3. T. Onisawa, "Fuzzy Reliability Assessment Considering the Influence of Many Factors on Reliability," *International J. of Approximate Reasoning*, **5**, pp. 265-280, 1991.
4. M. Galluzzo, V. Cappellani, and U. Garofalo, "Fuzzy Control of pH Using NAL," *International J. of Approximate Reasoning*, **5**, pp. 505-519, 1991.
5. L. J. Huang and M. Tomizuka, "A Self-Paced Fuzzy Tracking Controller for Two-Dimensional Motion Control," *IEEE Trans. on Systems, Man, and Cybernetics*, **20**(5), pp. 1115-1124, Sept. 1990.
6. S. G. Kong, B. Kosko, "Adaptive Fuzzy Systems for Backing up a Truck-and-Trailer," *IEEE Trans. on Neural Networks*, **3**(2), pp. 211-223, March 1992.
7. K. L. Harris, P. Sandland, and R. Singleton, "Wafer Inspection Automation: Current and Future Needs," *Solid State Technology*, Aug. 1983, pp. 199-204.
8. C. A. Harlow, et al., "Automated Inspection of Electronic assemblies," *IEEE Computer*, April, pp. 36-45, 1975.
9. M. K. Hu, "Visual Pattern Recognition by Moment Invariants," *IRE Trans. on Information Theory*, Feb. 1962, pp. 179-187.
10. K. J. Astrom and J. Wittenmark, *Computer Controlled Systems*. Prentice-Hall, 1984.
11. L. A. Zadeh, "Outline of a new approach to analysis of complex systems and decision process," *IEEE Trans. on Systems, Man, and Cybernetics*, SMC-3, No. 1, pp. 28-44, Jan., 1973.



# WHAT'S ALL THIS MENTAL EXERCISE STUFF, ANYHOW?

Now, I coulda titled this column "What's All This Alzheimer's Stuff?", but you would probably think I'm going on a health kick after the Diabetes and Carpal Tunnel Syndrome columns, and that's really not the point. Recently I got a neat mailing from Mead Killion<sup>1</sup>, who has invented some very good high-fidelity hearing aids. Write to him if you think that most hearing aids are lousy, and he'll send you some info.

One of the reprints he sent me showed that violins sound best when they're played a lot. A maker of very fine violins selected four freshly-minted



**BOB PEASE**  
OBTAINED A  
BSEE FROM MIT  
IN 1961 AND IS  
STAFF  
SCIENTIST AT  
NATIONAL  
SEMICONDUCTOR  
CORP.,  
SANTA CLARA,  
CALIF.

violins that sounded just about the same. A panel of experts listened to a good violinist play these four violins, and they agreed that all of them sounded about the same. Then the four violins were left in a controlled atmosphere—but two of them were taken out and "played" about 16 hours per day, by means of a mechanical link between a loud-speaker cone and the bridge of the violin. After three months, the panelists returned for a retest, and they agreed that two of the violins sounded *much* better. And they were the ones that had been "played." So Mead thinks the world needs an automatic violin player, to exercise a violin and keep it sounding good.

I wrote to Mead, suggesting that a violin may really like to be HELD and CARESSED, even as much as it needs to be bowed. So, I suggested that a little more research is needed. If you hold a violin without bowing it, or bow a violin without holding it, which sounds better? If 16 hours a day is good, is 24 hours better? Or is eight better? Is one hour a day enough to keep it in good form, after it is "warmed up" or "broken in?" There are a lot of things about this that we don't know. Is classical music better than playing scales?—or rock-and-roll? (Wouldn't that be a horrifying development!) If you're an aficionado of fine fiddles, you can write to Mr. Killion for that reprint.

But that was not the most interesting part of Mr. Killion's mailing. He enclosed a reprint from the *Chicago Tribune* about the human brain, and aging, and how researchers are beginning to understand a lot of how the brain works. Now, I bet a lot of you folks have parents or colleagues or friends who are getting OLD. Some of them are going to have diminished mental capacity. Some of them are probably going to get Alzheimer's disease. Some of them are going to get bad at thinking, or remembering, or even talking. I know it isn't politically correct to say that, but, there, I said it.

Some people have problems with their bodies getting old and others have troubles thinking, and then there are other people who keep their ability to think and remember. We're aware of Alzheimer's Disease, which is known to be related to a loss of ability to remember, or think, or analyze—or even talk. It's pretty much dreaded. When ex-President Reagan went public about his Alzheimer's problem, we all respected his bravery. We're all concerned about that problem, and more aware of it.

This reprint points out many kinds of interesting research on the human brain. The brain can repair itself, after certain kinds of damage, but mostly when it's young. Not really new info, but it's interesting to see all of these facts put together. The most interesting observation, I thought, was that the correlation between Alzheimer's disease and thinking now is being questioned. There are many people who despite being very old are still bright, perky, and quick at thinking. But after they die, an autopsy shows that their brain has all the signs of Alzheimer's disease—all the protein plaques, all the tangled nets.

The apparent difference is that these people kept their brains busy. They talked, they THOUGHT, they did puzzles, they did WORK. They kept mentally active and agile. So the preliminary recommendation is that if you want to avoid the symptoms of Alzheimer's disease, just THINK. Keep your brain active. The researchers feel that the "neurotropic factors"—the chemicals that keep your brain in good working shape—are actually MADE by THINKING. People who are losing their ability to think, talk, and remember are actually helped by tutoring and enforced mental activity. Needless to say, much research is going into this. Also, chemicals such as indomethacin, an anti-inflammatory drug, are suspected to be able to slow mental decline due to Alzheimer's disease—and to reverse some of the symptoms.

I've been recommending, in a common theme over many of my columns, that you should THINK. Don't just rely blindly on spreadsheets, on computers, on Spice, on other people, to do your thinking for you. My point has been, it's good for your business health, so you won't be fooled by computer goofs. And now these researchers think it's good for the long-term health of your brain.

One of my reviewers, who read the first draft of this, remarked bitterly, "Don't count on it." He observed that a person he knew, who was always very active mentally, was going downhill fast due to an early onset of Alzheimer's at age 50. That person was his mother. So, while it's a good idea to try and keep mentally active, if it doesn't work, don't be too astonished.

# PICO

ULTRA-MINIATURE  
SURFACE MOUNT  
DC-DC Converter  
Transformers &  
Power Inductors

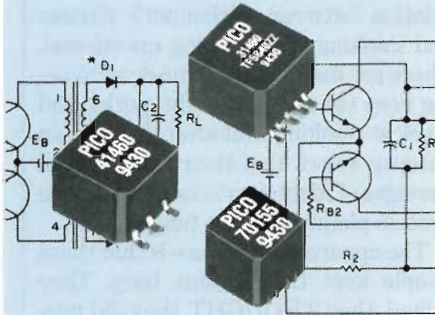

## Gull Wing / J Lead

These units have gull wing construction which is compatible with tube fed automatic placement equipment or pick and place manufacturing techniques. Transformers can be used for self-saturating or linear switching applications. The Inductors are ideal for noise, spike and power filtering applications in Power Supplies, DC-DC Converters and Switching Regulators.

- Operation over ambient temperature range from  $-55^{\circ}\text{C}$  to  $+105^{\circ}\text{C}$
- All units are magnetically shielded
- All units exceed the requirements of MIL-T-27 ( $+130^{\circ}\text{C}$ )
- Transformers have input voltages of 5V, 12V, 24V and 48V. Output voltages to 300V.
- Transformers can be used for self-saturating or linear switching applications
- Schematics and parts list provided with transformers
- Inductors to 20mH with DC currents to 23 amps
- Inductors have split windings

Delivery—  
stock to one week

See EEM  
or send direct  
for Free PICO Catalog.  
Call toll free 800-431-1064  
in NY call 914-699-5514  
FAX 914-699-5565

## PICO Electronics, Inc.

453 N. MacQuesten Pkwy., Mt. Vernon, N.Y. 10552

READER SERVICE 180

## PEASE PORRIDGE

Now let's say your great Aunt Tillie has been very bright and active, and does crossword puzzles every day. Then one day she just decides that she's not going to do crossword puzzles any more. Can we argue that the cessation of thinking is going to *cause* her brain function to go downhill? Or, has that downhill slide already started? Hey, I'm not going to argue that you should get a gun and *coerce* Aunt Tillie to continue to do those crossword puzzles. But it might be a factor. I know many "retired" old-timers who are very active mentally. "Retiring" is all a relative concept. They have "retired" from a formal job—but they volunteer at schools or museums, act as docents, study like crazy, take courses, take up a challenging new hobby, or actively carry on consulting businesses. Thinking is sort of a habit. So is sitting on a beach and goofing off, or watching the soaps. You take your habits, I'll take mine. But this is kind of an interesting area, and I suggest that all you guys THINK about it. Pass along the word.

After I got that one reprint from the *Chicago Tribune*, I must admit I made a few photocopies for some of my friends who would be most interested in this. I mean, Frank Goodenough, *Electronic Design's* editor on Analog STUFF, is over 70, but he still has a steel-trap mind. He reads ALL SORTS of stuff, and gives me tips on what I might want to look into. It's POSSIBLE that if he retired and sat on a beach, his brain would turn to mush in about eight months. But I bet we never find out, because Frank isn't gonna do that. Now I would LIKE TO recommend that everybody call up the *Chicago Tribune* and buy a copy or two of this excellent reprint.<sup>2</sup> I called them to buy 100 copies, but they only had 30 copies left. So I bought them all. You can buy one from me for \$3.00, while I still have them. I've asked the *Chicago Tribune* to tell me when they get more reprints back in stock.

Once I was staying in Minnesota at the Registry Hotel in Bloomington. In the morning, the electricity went out. It was kind of dark in my room, so I went down to the lobby. I knew they had a flame-heated coffee urn there for all guests.

That weekend, the U.S. 6th Army was having a 50th reunion. All of the guys who fought their way up the length of Italy in 1944-1945 had a reun-

ion in this hotel. There were some very nice people there, mostly about 70 years old. I got a cup of coffee and started up a conversation with one of the guys, Kingsley Mann from Michigan. We got to talking about people and ideas. After I got home, I sent him a couple copies of my columns, and he sent me a few reprints.

One reprint was about people who have suffered strokes. When a little blood clot blocks up an artery in your brain, part of your memory can be damaged. The interesting thing I learned from this study was that some stroke victims lose certain groups of words. Not just a whole lot of words, but SPECIFIC groups of words. For example, a person might lose only the names of animals. They might be able to talk about any other topic, but if you ask them a question that has an answer of bears or goats or cows, they can't say the word. They can think about those animals, but they can't say the word without extreme effort or coaching. That tells us something about the organization of the brain.

Other stroke victims are able to talk about nouns such as *a run*, or *a cut*, or *a flight*, but they can't use the words *running*, or *to cut* or *to fly*. They can remember all of the nouns, but they're unable to remember a lot of the verbs, even if they're the same words. Other stroke victims can remember a word that's a verb, but *not* the corresponding noun. So, that tells us something else about the organization of our brains. Kinda interesting. Enough to make you think.

All for now. / Comments invited!  
RAP / Robert A. Pease / Engineer

Address:  
Mail Stop D2597A  
National Semiconductor  
P.O. Box 58090  
Santa Clara, CA 95052-8090

1. "The effect of extended playing on the tone of new violins," Mr. Mead Killion, Etymotic Research, 61 Martin Ln., Elk Grove Village, IL 60007.

2. "How the brain keeps itself healthy," reprinted from the *Chicago Tribune*, Sept. 18-21, 1994. Call (312) 222-3080. The price is \$3.00 for one, or \$1.95 in quantity of 50 or more *when available*.



## PEASE PORRIDGE



# BOB'S MAILBOX

### Dear Bob:

I am often asked by my military customers for MTBF (Mean Time Between Failure) predictions, which the customer wants to predict spares holdings and to give himself a "Warm Feeling" about reliability. The problem is, I think predicted MTBFs (as opposed to measured ones) are nonsense!

As a designer of small-volume military equipment, my experience has been that *electronic* components selected appropriately, fitted correctly, and stressed well within their limitations (mechanically, thermally, and electrically) just don't fail. The sorts of things which *will* fail are switches, connectors, wiring, anything which suffers thermal cycles, or knocks, or gets wet. If I used MTBFs to write the spares holding, I know damn well they'd run out of connectors long before 33-k $\Omega$  resistors! Knowing these things is what makes designs reliable and maintainable in service—not some phony statistical garbage that few designers actually believe in!

Now before you tell me to go back to college, I do understand the *principles* of statistical failure analysis; I can read a databook and calculate how many thermal cycles a power MOSFET will stand before keeling over with its legs in the air. I just feel that the theoretical failure rates for electronic components are generally dwarfed by failure mechanisms for which MTBFs can't be calculated, or have little relevance. Nine times out of ten, a failure indicates poor design, manufacture, assembly, or misuse. What use is MTBF when the squaddy uses his new Digital Radio to knock in tent pegs, or snaps the antenna to avoid staying out on patrol? Don't laugh—these are real cases!

I can see that MTBFs might work in a very large production run in which process and design have time to be characterized well, and in which design or use problems can gradually be ironed out. But, in our fast-changing technology, how often is this true? As a semiconductor designer, Bob, what

do you think. Do you calculate your failure rates, or do you measure them?

### ANTHONY NEW

*BAeSEMA Marine Division  
Bristol, England*

*Yes, Anthony, I did write about MTBF stuff, in the Oct. 24, 1991 Electronic Design—"What's all this Mil-HDBK-217 Stuff, Anyhow?" Yes, we agree that a well-designed modern electronic system is very reliable these days—if you beware of Moving Parts. On all our new ICs, we burn in big samples and check for short-term, medium-term, and long-term stability. They gotta be pretty good, before we will release them.—RAP*

### Dear Bob:

Thanks for your column on diabetes and lifestyle that appeared in the April 17 issue. Diabetics have their own eye disease called diabetic retinopathy. It affects capillaries in the retina, causing leakage, blockage, and proliferation of weak, bleeding new capillaries.

Risk of developing this disease increases with time, severity of diabetes, and poor management. Approximately 80% of insulin-dependent diabetics develop retinopathy within 25 years. Without treatment, 50 to 60% of these become blind. This was once the most frequent cause of new adult blindness in the U.S.

At present, the preferred treatment is laser photocoagulation. Using an argon ion laser, the ophthalmologist treats the peripheral retina to prevent formation of the weak vessels. The procedure is usually done on the doctor's office with minimum discomfort for the patient. Using this treatment, only about 1% become blind.

An estimated 10 million patients have been treated by lasers made by my company since 1971. Currently, at least 30,000 patients per week are treated. Anyone diagnosed with diabetes should have an eye exam by an ophthalmologist, as treatment is most effective if started early.

The above information was col-

lected by Tom Brunner of the Coherent Medical Group. Tom managed the team that developed the first commercial argon laser photocoagulator.

From an EE's point of view, the most challenging part of designing these instruments is the assurance of safety. The present designs use dual control systems in which no single part failure can cause an accidental overexposure. The systems are tested every time the instrument is turned on. No dangerous overexposure has ever been reported with this design. This job sure beats working on "STAR WARS!"

### ROBERT J. RORDEN

*Coherent Inc. Medical Group  
Palo Alto, Calif.*

*I am impressed by the excellent engineering, and the safety and performance of your equipment.—RAP*

### Dear Bob:

I was really surprised at your July 24 column about UNIX. Firstly, I'm used to you commenting on something you know something about, rather than from a position of ignorance. Secondly, the book you reference is probably the least accurate and fair book about UNIX's failings, so people wishing to know about UNIX and/or its failings should NOT buy that book. Thirdly, you even quoted some parts that aren't about UNIX! For example, C++ has got no more to do with UNIX than it has to do with MS-DOS, VMS, or MVS.

That quote about "losing a file in a large hierarchical" is priceless: Ever tried looking for a file in a flat file system with thousands of names? In any case, UNIX is by no means the only system with a hierarchical file system. A lot of today's successful systems have them (e.g., MS-DOS and VMS).

Many other things in the book are just garbage, not the least of which is the reference you gave to UNIX staying up for weeks at a time. Vast numbers of systems run for months with no unplanned stoppages.

Sure, there are some things wrong with UNIX—the biggest being the





Turn your **excess inventory** into a substantial tax break and help send needy **kids to college** as well.

Call for your **free guide** to learn how donating your slow moving inventory can mean a generous **tax write off** for your company.

Call (708) 690-0010  
**Peter Roskam**  
 Executive Director



P.O. Box 3021, Glen Ellyn, IL 60138  
 FAX (708) 690-0565

*Excess inventory today...student opportunity tomorrow*

## PEASE PORRIDGE

utter failure of the manufacturers to pull in the same direction! Not to mention their habit of underestimating Microsoft, fighting yesterday's war (e.g., worrying about the desktop five years too late).

And no, I don't sell UNIX. I do have an ancient UNIX system here as a server, though. Please go back to your usual well-informed commentary! Retracting your UNIX comments would be a good idea, too.

**JOHN SKELTON**

*Via e-mail*

*I have had a fair amount of grief with UNIX. The complaints of authors Garfinkel, Weise, and Strassman are also consistent with the observations of my colleagues. But I am glad YOU enjoy working with UNIX. Personally, it ticks me off when I type "print SPEEDINGj" and the stupid computer replies, "cannot access SPEEINGj." That just ticks me off. WYS is not WYG.—RAP*

**Dear Bob:**

Bill Sturgeon's idea of charging for home delivery of mail and free P.O. Boxes (Sept. 15 issue) is not a good idea. Even though you may elect to use a P.O. Box, if your neighbors on either side of you use home delivery, the Post Office has saved nothing—not to mention the crowds and traffic jams around the Post Offices if there was a major shift to using P.O. Boxes. If we're going to start thinking that way, we should charge the good citizens of Alaska and Hawaii a premium for mail delivery; unless, of course, they choose to use a P.O. Box located in the lower 48 states....

**MARK SEBALD**

*Waukesha, Wisc.*

*If I go right by the post office every day, I can't think of a good reason not to stop in and pick up my mail. I'm not asking for a cheaper mail rate. I just think I should not have to pay EXTRA, for Box Rental.—RAP*

All for now. / Comments invited!  
 RAP / Robert A. Pease / Engineer

Address:  
 Mail Stop D2597A  
 National Semiconductor  
 P.O. Box 58090  
 Santa Clara, CA 95052-8090