

# *A Tribute to Bob Pease*

**Pease Porridge – 6 (2005-2007)**

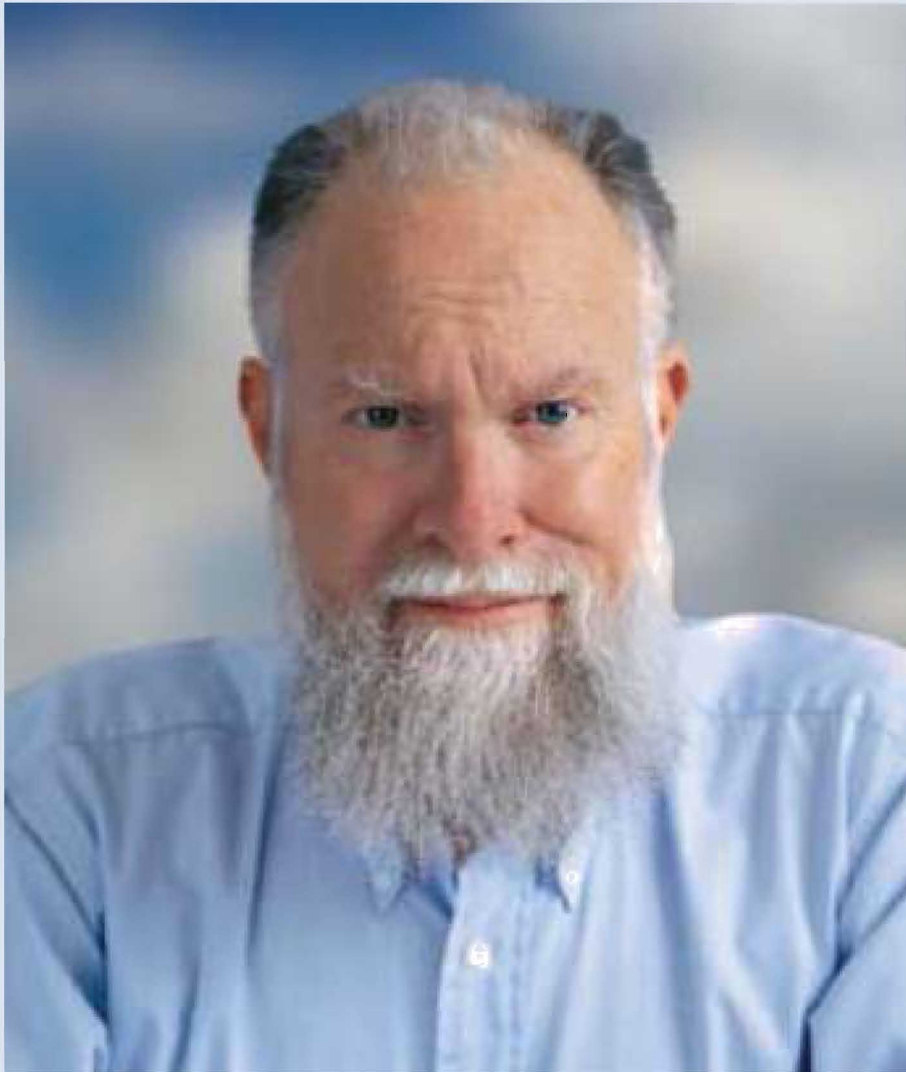



**Pease**PORRIDGE

**BOB PEASE**, *Contributing Editor*

• • • rap@galaxy.nsc.com

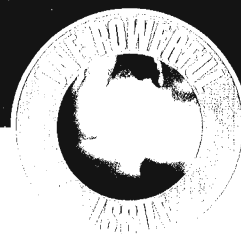

# WHAT'S ALL THIS RESONANCE STUFF, ANYHOW?

I was walking down a hallway on the top floor of NSC's building D, when something I heard made me suspicious. It sounded like a series of tiny clicks rattling around the hallway. I stopped and slapped my thigh to make a sharp sound. I heard TICK-TICK, tick-tick, tick-tick. I was surprised, because there was no obvious reason why this hallway should do this. It even had a carpeted floor. I tried the slap in several other hallways—and in tile bathrooms—and got almost none of this effect. What's going on?

I decided to tape the effect, and if I could see the timing of the clicks on my scope, that might be a clue. After all, the hallway goes 270 feet from one end of the building to the other. I'm standing near the middle when I get the best reflections. But there are other frequencies and time relationships in there to study. I'll let you know what I figure out.

I was lying on my bed a while ago, humming, when I heard a strange humming below me. I tuned my hum up and down—there it was at 336 Hz. The mattress was resonating. The funny thing is that this is not just a simple resonance or simple forced damped harmonic motion. When I stop my burst of humming, the amplitude then grows for another half-second, and then it slacks, and then it grows even bigger. Let's see if I can tape this. I may need a limiter amplifier so the recorder isn't fooled by its AVC loops and the initial hum doesn't drown out the rest. See the oscilloscope photo for the results of my taping experiment.

Nope, sorry. Even with the preamp, I couldn't get a clean recording. So the scope photo shown is just a (poorly) simulated waveform.

I've been on the road for quite a few days this fall, and every time I come to a new hotel, I hum at the mattress. I hear a little resonance, but not nearly so much. I haven't got any good calibration for all those frequencies. I'm not going to say that my mattress at home is all worn out or is of lousy construction. I'm just saying that if I had to invent a circuit or structure to make the resonance act like that, I would be puzzled how to do it. I only hear one frequency. not two.

When I go hiking up in the Marin Headlands, or Fort Funston, there are several large concrete tunnels left over from World War II. They're perhaps 20 feet high and 200 feet long. My sons early on figured they could hum and set up some great resonances. I don't know what the Q is, but—several seconds. A Q of hundreds... Of course, they called this "Tunnel Hum." It must drive the other tourists and hikers crazy. We can't resist it!

Many barbershop quartets like to rehearse and record in a concrete stairwell, at least for some songs. They really seem to like that resonance. With only four people in the stairwell, they don't damp out the resonance as they would if there were 40 people. But stairwells seem to provide better results even than a tile bathroom.

I go to church at Grace Cathedral in San Francisco. This is, structurally, a great beautiful concrete barn, and it has a seven-second resonance. This means the organist has to wait after a loud chord and wait a couple seconds more than usual before playing the next chord. When they get the church more than half full, this cuts down to perhaps four seconds. Brass players specifically have to wait for the bright tones to die out. It makes a difference how you play!

What resonant frequency and Q do you get out of your mattress? I gotta slide over to my wife's side and see if its frequency is any different. That might explain why the energy comes up gradually. But the Q has to be well over 100.

Comments invited!

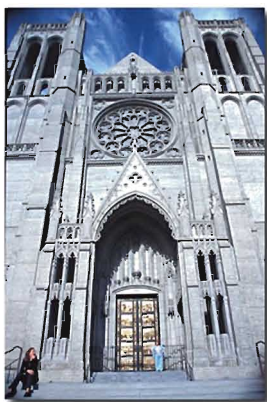

GRACE CATHEDRAL IN SAN FRANCISCO. THIS IS, STRUCTURALLY, A GREAT BEAUTIFUL CONCRETE BARN, AND IT HAS A SEVEN-SECOND RESONANCE.



**Pease**PORRIDGE

**BOB PEASE**, *Contributing Editor*

• • • rap@galaxy.nsc.com

## BOB'S MAILBOX

Hi, Bob: I have a problem and could use your help. It initially sounded easy to me, but proved not so. I need to find an analog circuit for the following problem: I have 13 resistors with different values. I know the list of values and need to randomly pick two resistors from those 13 to put into the circuit.

The circuit should be able to tell me which one is the larger resistance value. If possible, please provide some advice on this problem that has puzzled me for a while.

**Tiejun** (via e-mail)

**Pease:** Hello, Tiejun. It might be of interest for you to study the range of those resistors. If you load a 0.1- and a 0.2-> resistor onto a 5-V bus, you might get a stupid answer if they are destroyed by overheating. There are many ways to compare resistors' ratios. Some use an op amp, while others use a comparator. Most use a matched pair of resistors as a divider, so if the unknowns are close together in ratio, you won't be fooled. This is usually called a bridge, such as a Wheatstone Bridge. Did they ever teach you about bridges, which were used for 110 of the last 120 years? Set up your unknown resistors as a voltage divider. Set up the matched resistors as a voltage divider. Provide a bias voltage. If the resistors are ill-matched, it is very easy to see: The comparator or op amp tells you which R is HIGH.

**Dear Bob:** I read your Pease Porridge column all the time and love it. Now I have a question for you. I have a component that I have to source out and I'm having trouble finding it. The logo on the part is of a pair of hands doing a handshake. Do you know if this is an old National Semiconductor symbol? (I sure doubt it. /rap) The part is some type of video amp for a CCD array. Any info would be greatly appreciated.

**Steve A.** (via e-mail)

**Pease:** Man, I never heard of this nor saw this. I'll ask around. And perhaps some of our readers might know?

**Dear Bob:** Regarding "What's All This Magazine Stuff, Anyhow?" (electronic design, Nov. 15, 2004, p. 18). The word "magazine" is derived from the Arabic word makhzan, meaning storehouse per [www.bhag.net/word/word24aug2003maga.html](http://www.bhag.net/word/word24aug2003maga.html) and my memory as someone (with some Arabic) who lived in Morocco for two years.

**Fred White** (via e-mail)

**Pease:** Hello, Fred, I am a bum for neglecting to include the etymology. I always like to do that, and I can't think of why I neglected to include it in my column. Thank you for mentioning this. But if you went back to Morocco, what do you think a storehouse is now called? If I went back 500 years to old England, what do you think a storehouse was called?

Comments invited! rap@galaxy.nsc.com —or:  
Mail Stop D2597A, National Semiconductor  
P.O. Box 58090, Santa Clara, CA 95052-8090

### TREKKING WITH BOB PEASE

Anybody interested in a great bicycle trek around the Annapurna Circuit? It was pretty tough when we did it in 2002, but I got a couple more friends who want to do it, so I might just go again. We'll be starting up the trail on June 1, 2006. Read about that trek at [www.national.com/rap/trekking/bek/index.html](http://www.national.com/rap/trekking/bek/index.html), parts 14 and 15. Only tough, strong, mountain bikers AND good hikers should apply. But it will be a lot easier for us than our 2002 trip, as we know when and where to hire porters, and how to keep our weight down. Inquire to rap@galaxy.nsc.com.

Is anybody interested in joining us on our next hiking trek in November 2005? This is an easier hike, up from Pokhara to the Annapurna Sanctuary—just 14,200 ft, with the great Annapurna peaks rising 10,000 ft above us, all around, and the full moon overhead on November 15. Our highest camp is at 12,200 ft. Then we traverse to Ghorapaani and Poon Hill for more great views. This is just a 25-day trek. Pricing is around \$1600 plus ~\$1400 for airfare from the west coast. For more information, go to [www.instantweb.com/p/peterowens/Annapurna%20Sanctuary%20Camping2004.htm](http://www.instantweb.com/p/peterowens/Annapurna%20Sanctuary%20Camping2004.htm). Save up for your vacation now. Inquire to rap. Do it early because space is limited to about 12 people. /rap



# WHAT'S ALL THIS COMPARATOR STUFF, ANYHOW?

There are many comparators that you can buy to provide quick (sub-microsecond) response when a large signal changes and crosses a threshold voltage, such as a reference voltage. Unfortunately, comparators don't work well when the input signals are very small. The ability to respond correctly, without offset, drift, or noise, is normally impossible to do with a comparator unless the signal is moving more than a millivolt beyond the reference voltage. And with a comparator, you can't add a chopper-stabilizer because the comparator's offset voltage is unknowable when the input signal applied to the inputs may be many millivolts or volts.

Here's an application where the LMP2011 can act as a precision comparator with better than 10  $\mu\text{V}$  of resolution and precision. Yet by closing its feedback loop continuously, the op amp maintains full dc precision, low offset, and negligible drift.

In Figure 1, the signal is brought in to the summing point through R1. If the desired threshold point is zero, R2 isn't needed. (But if a particular reference voltage  $V_{REF}$  is needed, R1 and R2 must be closely matched so the output will trip when  $+V_{IN}$  crosses ( $V_{REF}$ ).)

Alternatively, if the reference voltage is small (less than 100 mV) and at low impedance, it could be connected to the positive input of the LMP2011 through R4.

The summing point voltage of the LMP2011 is maintained within a few microvolts of its positive input, basically all the time. When the input crosses zero millivolts in a positive direction, the output starts to move down from its limit value, such as +1.4 V. Positive feedback is applied through the R5-R4 divider to drive the positive input negative, increase the response speed, and supply dc hysteresis. Further, ac hysteresis is applied through the R6-R4 divider. So for a short time, additional positive feedback voltage is applied to the positive input--but only for a short time. When R6-C1 has discharged, the hysteresis will be restored to the dc value of about 15  $\mu\text{V}$  p-p, or  $\pm 7.5 \mu\text{V}$ . This is important to get freedom from noise or oscillation when the input signals are very small.

Using 2N3904s as diodes is very important for full accuracy because most ordinary diodes are much too leaky around  $\pm 60$  mV to work well. Ordinary gold-doped 1N914s or 1N4148s are quite unsuitable due to their high leakage and conductance, even at room temperature.

The observed delay time for signals as small as  $\pm 10 \mu\text{V}$  is about 5 ms, decreasing to 0.8  $\mu\text{s}$  for large signals. See the chart of delay time versus signal amplitude. In some cases with small input signals, less than 1 mV, the delay time can be reduced by a factor of three or four by using lower values for R1 and/or R6, such as 2 k $\Omega$ . The improvement in delay time isn't quite as big a factor for large signals. Using low values for R6 may cause dynamic errors or delays if the input waveform is asymmetrical in amplitude or in duty-cycle.

Comments invited!

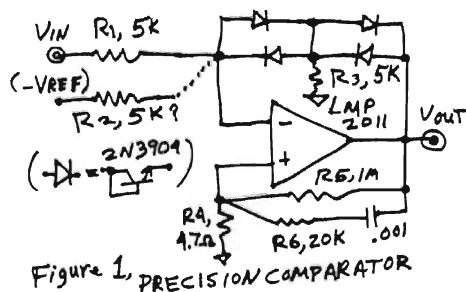

Figure 1, PRECISION COMPARATOR

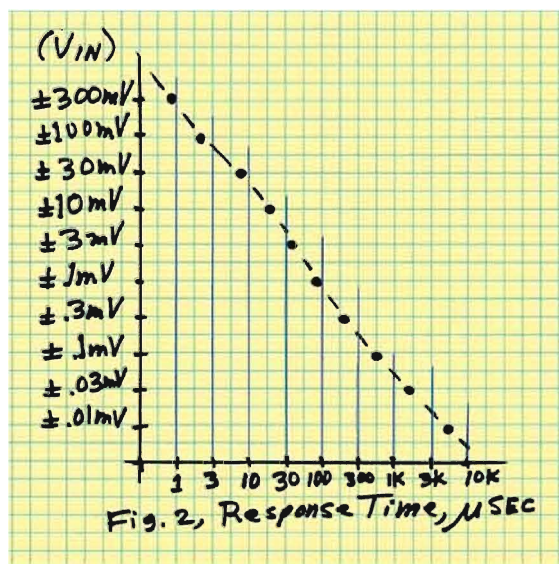

Fig. 2, Response Time,  $\mu\text{SEC}$



**Pease**PORRIDGE

**BOB PEASE**, *Contributing Editor*

• • • rap@galaxy.nsc.com

## BOB'S MAILBOX

Hello Bob: I am looking for professional opinions/experiences regarding pc-board assembly using eyelets. I was told by Sam Reaves that you had written on the subject and could probably offer some good information. The problem that I am facing is that we are using eyelets on some pc boards in an effort to make the joints stronger. But I have seen some failures that are due to the eyelets. I need information to lead me to the correct decision and to use to convince others.

*(Yeah, in my pretty good book on Troubleshooting Analog Stuff (p. 55), I said about 14 years ago that many people had given up on eyelets. They are unreliable when cycled over many cycles. Myself, I preferred to use double-plated-through holes, and I put wires through, and nobody ever argued with me that my solution was wrong, compared to eyelets. /rap)*

I am of the opinion that the eyelets do not offer much insurance for a good solder joint, and in some instances they can and have become a liability. *(You have shown that eyelets have lousy reliability. [That is a technical term.] It is not to put the onus on you to show that the eyelets are lousy. If the guys selling eyelets cannot show a mode of applying the eyelets to make them reliable, then throw them out in two minutes. /rap)* What is your experience regarding eyelets and solder-joint quality? *(I have had very little experience myself, but the guys who say they are bad have never been, to my experience, contradicted. The burden is on the peddlers, and I'd be surprised if they can beat it. /rap)*

The application is an electronic lighting ballast. The pc board is single-sided, and the eyelets are used on the BJTs. I prefer plated-through holes, but because of cost they are not very practical. The eyelets were added to the BJTs because it was believed that they were one of the highest-stressed joints on the board, both electrically and mechanically in the manufacturing process. Because of the inconsistency I see with the eyelets, I think I may be better off with a regular nonplated-through-hole pc board. What is your thought on that?

**Jason Cook**

(via e-mail)

**Pease:** *As you have a pc board where plated-through holes are not cost-effective, can you add wire stitches to connect through the board? Try some experiments. Add bigger foil lands for that transistor to bear the stresses and get the heat out. Your pc-board vendor must have some advice.*

**Dear Bob:** In your recent "Bob's Mailbox" (electronic design, Nov. 29, 2004, p. 20), you mention that the low-leakage diode trick with the 2N3904 (my favorite part) should leave the emitter unconnected. *(The column I just wrote for the last issue uses 2N3904s, too [electronic design, Feb. 3, p. 18]! /rap)* Why can't the base and emitter be connected together and still yield the low-leakage characteristic of the base-emitter junction?

**Dave B.**

(via e-mail)

**Pease:** *It will do no good and no harm to connect the B to the E. But it is important not to connect the base to the collector. That makes an excellent diode, very fast (sub-nanosecond) with low leakage—but just for 3 or 4 V.*

**Hi, Bob:** Your column on "Merit Badge Stuff" (electronic design, Dec. 18, 2004, p. 20) inspired me to e-mail you. I earned the Electronics merit badge in the late 1970s. And the Computers merit badge, too. Funny that I ended up majoring in biochemistry for my first semester of college and then switched to EE. Been a professional EE for over 16 years now with only one month out of work last year.

Now I think my nine-month-old son will grow up to be an EE, too. I just found out that he was born on Gustav Robert Kirchoff's birthday (March 24th)! Isn't this a great way to make a living? (Pointy-haired bosses notwithstanding.)

*Jim Ford (via e-mail)*

**Pease:** *There are many ways to have a satisfying job in electronics! Even if you were—or weren't—born on Kirchoff's birthday. Best regards, and best wishes to your son.*

Comments invited! rap@galaxy.nsc.com —or:

Mail Stop D2597A, National Semiconductor  
P.O. Box 58090, Santa Clara, CA 95052-8090



**Pease**PORRIDGE

**BOB PEASE**, *Contributing Editor*

• • • rap@galaxy.nsc.com

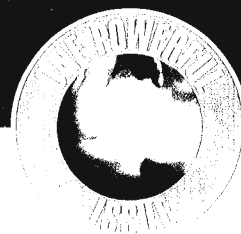

# WHAT'S ALL THIS CONDITIONING STUFF, ANYHOW?

Recently I got an e-mail from a friend, bemoaning that he ran out of breath while trying to climb a 14-er in Colorado. He was upset that he had to turn around at the 11,000-ft level and go back down with the women. I suggested that he use the Bob Pease Conditioning Scheme. You don't have to drag a "Stair-Climber" or treadmill inside a simulated high-altitude chamber, evacuated to 14,000 ft. You just have to walk and run up and down stairs--and not in a 20-story building (though I've done that, too). I do this running in my own house, where one flight of stairs is 9.90 ft high. I step with both feet on the ground floor and with both feet on the top level. I keep a good count. I keep up a good pace for 20 minutes. Then I lie down to rest a few minutes, and cool off, and take a shower.

I start out fast, two steps at a time ascending, and I scamper down. I slow down gradually to four or three flights per minute, and I always breathe through my nose. That's a good way to get your lungs in shape for high altitudes. Running up is great for your uphill muscles, and running down is great for your downhill muscles. Back in 2000, I got in really good shape for trekking in Nepal. I ran up (and down) 33,000 ft of stairs over several months. Then when we hiked up to Everest Base Camp, at 17,800 ft, and Kala Pattar at 18,600 ft, I was definitely in the best shape of all the (younger) guys. Muscles breathing. I walked away from them. Of course, you have to keep hiking (or skiing, or bicycling) or whatever you are going to be doing. You need that, too.

How do I count the number of flights? I don't literally them. I time them. I use an analog clock with a sweep-second hand to note what rate I am making, such as four flights per minute, exactly on the quarter minute. If I've done two minutes at five flights per minute, (every 12 seconds) and six minutes at four per, and then nine minutes at three per, plus a couple flights that I "gained" when I was going a little faster than three per, that adds up to 63 in 20 minutes. It's a surprisingly good way to "count." And surprisingly good exercise. And a well-calibrated method. It's easy to not cheat!

At the foot of the stairs, along with the clock, I set a big glass of water, which I need at ~12 minutes, and a towel to dry off my face, etc. When I'm in good shape I can do 80 to 85 flights in 20 minutes, in the comfort of my home, any hour of day or night, rain or shine. (Or in a hotel.) Usually, I use the stair-rail, but sometimes I don't. Obviously, I have to be careful not to trip or fall. Sometimes I wear light shoes; sometimes my heavy boots. I'll be doing a lot more of this shortly to get in shape for my next treks electronic design, and for some snowshoeing.

## DISCLAIMER

Any exercise program must be taken in moderation, in view of your own physical condition. Don't try to start too fast. Start at an easy rate, and work your way up to a vigorous rate. It's a good idea to keep your heart rate below your recommended rate for your age. Some people say 200 minus your age is a good maximum heart rate. If you are in doubt about your health for such vigorous exercise, consult your physician. Be careful not to fall on the stairs. And if any part of you gets unhappy with the exercise, slow down and take it easy!

And, for best acclimatization, try to ascend no more than 1000 ft/day, as we do when we're trekking in Nepal. In Colorado, nobody does that!

Comments invited! rap@galaxy.nsc.com —or:  
Mail Stop D2597A, National Semiconductor  
P.O. Box 58090, Santa Clara, CA 95052-8090

---

**BOB PEASE** obtained a BSEE from MIT in 1961 and is staff scientist at National Semiconductor Corp., Santa Clara, Calif.



**Pease**PORRIDGE

**BOB PEASE**, *Contributing Editor*

• • • rap@galaxy.nsc.com



# WHAT'S ALL THIS POWER STUFF, ANYHOW?

Sometimes a lot of power is just right. Sometimes 200 hp in a car is a lot better than 100. Sometimes even 1 hp gets a bicycle up the hill quite fast. Yet a bicycle can cruise along at 6 or 8 mph with less than 0.1 hp. That's part of the elegance of the bicycle, as an extremely efficient mode of transportation.

Yet by using external sources of power, I can go uphill much faster than I can by pedaling my bike. The dollars per mile can drop way down, if I count my time at even \$5 an hour.

A 747 at takeoff is generating perhaps 50,000 hp. Yet its controls rely on tiny forces and low-power circuits, in the milliwatt or microwatt levels. Radio signals may be kilowatts when transmitted, but nanowatts when received. We engineers require the ability to comprehend this entire range of power—and to engineer control circuits that are appropriate.

Power is useful when it's in the right place, yet it can be disastrous in the wrong place. So, our task is to keep power in the right place. Sometimes a plain old linear regulator with an efficiency of 30% to 50% is just right. Many other cases definitely call for a switch-mode regulator.

Recently we had a high-power, high-current, high-speed, medium-voltage driver. A potential customer asked us if we could soup it up from 5 V of  $V_S$  to 8 V to drive a couple hundred milliamperes into a higher-voltage load. Well, we said, it does no harm to try. We applied the juice and monitored the temperature of the calibrated ESD diode, which was at the edge of the die. It went up to 175°C. One of the engineers said, "Well, it's a good thing the temperature is constant, all across the die, because we really don't want it to get hotter than that, for best reliability."

But a couple of us guys were suspicious. I computed that the middle of the die could be 60°C or 70°C hotter than the edge. We got mad and etched away the encapsulation and took an IR photo. The middle of the die was indeed 85°C hotter than the ESD diode. It ran at 260°C, all weekend. On Monday, it was still working fine. Then we had to tear down that experiment to do other tests. But we showed that this part could handle a lot of power, get the heat out, and keep running well.

We wouldn't want to recommend that the part would run this hot, for good reliability. But if we added a decent heatsink, we could keep it cool enough to run reliably. Getting the milliamperes out does make it challenging to get the heat out, but not impossible. (A metal heatsink does a much better job than a paper heatsink.)

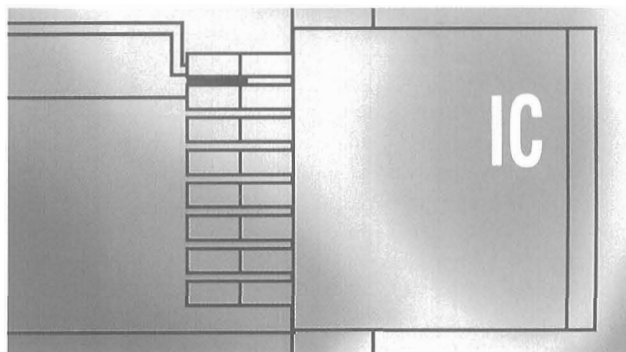

This computer-simulated photo shows how the heat is concentrated in the center of a hot die.

## BOB'S MAILBOX

**Dear Bob:** About "Resonance Stuff" (ELECTRONIC DESIGN, Jan. 13, p. 22): That is an interesting tale and one that I have also experienced! My wife inherited this cabin up in western Mass., and it was a very basic structure with a simple bed that had a coil spring frame to support the mattress. The open springs had very high Qs, so any humming or spoken sound while lying on the bed was amplified considerably! I never took the trouble to haul up a mic, preamp, and scope to analyze this, but we used to joke about the springs doing this! I don't quite follow what the picture of the scope trace in your article is displaying, other than that it looks like bursts of some frequencies!

• **Dale B. Blackwell** (via e-mail)

• **Pease:** As I said, it was a poor simulation. The real amplitude (as soon as I stopped humming) was at a moderately low level, and then the amplitude rose by 3 dB, then fell by 3 dB, and then rose 6 dB, then fell off, after a total delay of a couple of seconds. **ED**

Comments invited! rap@galaxy.nsc.com —or: Mail Stop D2597A, National Semiconductor P.O. Box 58090, Santa Clara, CA 95052-8090

**BOB PEASE** obtained a BSEE from MIT in 1961 and is staff scientist at National Semiconductor Corp., Santa Clara, Calif.



# ALL WHAT'S MAILBOX THIS ANYHOW, STUFF?

**Dear Bob:** Regarding Jason Cook's question on eyelets.\* I worked at Motorola in the '60s, when eyeleted pc boards were still being used. In the days before plated holes were common, eyelets did prevent foil from peeling when a board was repaired, and they were the only way to get vias on two-sided boards.

The eyelets were specially designed "double funnel" and had to be inserted properly so the funnel would split on the top side to allow solder to wick up.

But they did cause headaches because of solderability problems. We found that the plating had a shelf life. If the eyelets weren't used promptly, the surface would corrode or get contaminated. Or if they rattled around too long in the eyeleting machine's hopper, the plating would wear off. A bad eyelet was impossible to see and very difficult to repair. Not only that, a bad eyelet would cause an intermittent fault that might not show up until the board was temperature-cycled or shipped to a customer. As soon as plated holes became affordable, the eyelets were all designed out.

\* **Ken Lundgren** (via e-mail)

• **Pease:** *I always heard that the eyelets would adhere to some of the nearby foil, and then when thermal expansion occurred, the eyelet would lift this foil away from the main part of the foil, and the foil would crack in pieces. Maybe that's not the major fail mode, these days. I have used thin wire through holes and then soldered over, top and bottom. Any two of those, in parallel, are much better than an eyelet, in my opinion. (We have done this with homemade boards, when the delivery on plated-through holes was too slow.)*

**Dear Bob:** Your column on "Resonance Stuff" (ELECTRONIC DESIGN, Jan. 13, p. 22) was especially noticed by me because of my own experience in my childhood. In 1945, at the tender age of 12, I developed an interest in ham radio. I thought I would build myself a crystal radio using a galena crystal. Nobody seems to know what that is these days, but you surely do! (Galena is lead sulfide, a fair semiconductor, capable of making a rectifier. /rap)

Anyway, at that time I lived in Hackensack, N.J., just off Route 17, about a mile from where a 50-kW AM station on 770 kHz resided. The station was then called WJZ, the flagship station of ABC. During the summer, when it was hot, I used to leave the door open, with a screen door keeping out the mosquitoes that N.J. is noted for! The first night when I went to bed, I thought I heard some music and people talking. Using my ears as a directional antenna, I moved around until I found the source. The

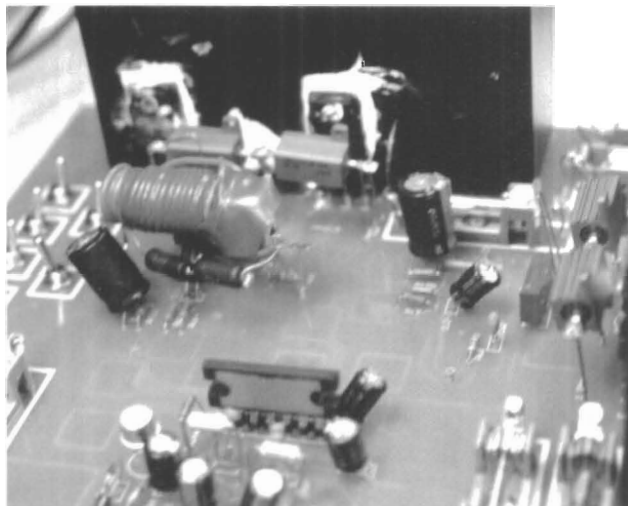

screen, in the screen door, was vibrating and causing, I guess, rectification of the RF coming out of WJZ! Wearing a pair of headphones, I poked around with the pin-jacks on the headphones, and I found a place on the mattress spring where I could connect the jacks with clip leads. I was able to fall asleep every night to music without a radio and batteries!

• **Diran Varzhabedian** (via e-mail)

• **Pease:** *Thanks for the excellent story. I've heard of people whose tooth fillings can similarly rectify out radio signals, and they can hear the radio in their head. This could be used to fake psychic seances. BO*

(If you wondered about the headline, Happy April Fools! /rap)

**Comments invited!** rap@galaxy.nsc.com —or: Mail Stop D2597A, National Semiconductor P.O. Box 58090, Santa Clara, CA 95052-8090

\*ELECTRONIC DESIGN, Feb. 17, p. 20

**BOB PEASE** obtained a BSEE from MIT in 1961 and is staff scientist at National Semiconductor Corp., Santa Clara, Calif.





# WHAT'S ALL THIS "WOMAN SCIENTIST" STUFF, ANYHOW?

After the president of Harvard, Dr. Lawrence Summers, got in hot water for questioning why so many women may not have the aptitudes for science, now it is my turn to put in my two-cents worth. The aptitude of women to be good at science, or engineering, is well documented to be at a lower rate than it

is for men. This has been widely published by the Johnson O'Connor Research Foundation ([www.jocrf.org](http://www.jocrf.org)), which has been studying aptitudes since 1922.

If you take the top 1/4 of men in this aptitude, many of them are the extremely good scientists and engineers. Then take the top 1/16 of women—they are just as sharp at these physical relationships, which the JOCRF calls "Structural Visualization" (S/V), with a similar distribution of excellent skills. I mentioned this in my column on "Aptitude Stuff" (*ELECTRONIC DESIGN*, Nov. 3, 1997, p. 219). (Also see [www.jets.org/latestnews/JOCRF-article.cfm](http://www.jets.org/latestnews/JOCRF-article.cfm).) Now, not every kind of science or engineering requires this S/V, but many do.

So I tend to support that poor beleaguered man, Dr. Summers. He just happened to have the bad luck to be the president of Harvard while he was telling the truth, or at least asking the right question. Give or take a few percent, I think he is largely right. Some people then bleated, "But there are many women who excellently head science departments at many major universities." One cannot argue against these facts, as they are facts.

But just because a woman is running a science department, it does not necessarily mean she is a great scientist—and it does not mean she is not a great scientist. Rather, it means that she is a good administrator and is good at getting along with the wild-men (and women) scientists. That by itself is an admirable art, and a very good talent, but not necessarily directly related to being good at science. This is sometimes called "herding cats."

It's too darn bad we all have to be so (bloody) politically correct these days. And, it's too darn bad that some people have to be so touchy about situations that have been documented as *factual*.



Also, note that some studies show that men who are good at engineering and science get those traits from their mothers. It is not yet well stated where the great women scientists get their aptitudes from.

Was my mother very scientific? I don't ever recall debating her on science. But my mother, Beulah K. Pease, was a schoolteacher for over 40 years, and I would say that her common-sense attitudes were never far from science. And I score at the 99th percentile—or higher—on all the S/V aptitude tests. My wife and both sons are very high at this S/V, also.

Meanwhile, all of us who are good at science and engineering should go out of our way to help any kids who are good at science and/or math—or, indeed, whatever they are good at. We really must encourage young people, and especially women and minorities, when they show a spark of brilliance and natural aptitude.

Girls are often discouraged from taking careers in math or science, and we should not let that happen. I can't easily nor seriously encourage (by example) a kid at drawing or music, but I can do something for kids in science or math. Give her (or him) a Heathkit!! (More on this later...)

Do you folks all agree? Or do you think I should apologize (like Dr. Summers) for what I said here? Fat chance! ☹☹

---

BOB PEASE obtained a BSEE from MIT in 1961 and is staff scientist at National Semiconductor Corp., Santa Clara, Calif.

**Read the Rebuttal:** Editor-in-Chief Mark David has invited the IEEE's Women in Engineering to respond to Bob Pease's viewpoints (which do not necessarily reflect the opinion of Electronic Design or Penton Media). For the rebuttal, go to [elecdesign.com](http://elecdesign.com), Drill Deeper 10117.





## Yes, Engineering Is A Woman's Job

As a woman engineer, I have worked for over 25 years to encourage more girls to pursue careers in science, technology, engineering, and mathematics (STEM). I had to stifle my screams and overcome my first inclination to label both Larry Summers and Bob Pease as Neanderthals (or worse) after reading Mr. Pease's column in the April 14 issue of *Electronic Design*. Instead, I decided to apply my analytical reasoning skills (a highly desirable aptitude for pursuing an engineering career) to Mr. Pease's arguments to see if there was any "there" there.

I found that intrinsic aptitude differences between the sexes are not that significant. The scholarly research on the whole question of nature versus nurture has found that gender differences on science and math tests are small and decreasing and that a significant number of complex and not well understood factors, including expectations, influence performance.<sup>1</sup> If genetic and intrinsic aptitude explained why women still constitute such a small percentage of the STEM workforce, how does one explain the increase in female, undergraduate students studying engineering in the U.S.? In 1970, 0.3% of the degrees awarded nationwide went to women. Now women earn almost 20% of the engineering degrees. This is an increase in magnitude of over 60 times. Surely women haven't improved their quantitative skills by this magnitude just in the last 30 years. Factors other than aptitude must account for this result.<sup>2</sup>

The National Academy of Engineering's (NAE) treatise, *The Engineer of 2020: Visions of Engineering in the New Century*, commented on the rapid pace of technological change. The engineering profession will be driven in the next 15 years, this report predicts, by breakthrough technologies including biotechnology, logistics, high-performance computing, materials science and photonics, and nanotechnology. To function in this quickly evolving world, future engineers must not only possess critical thinking skills but also strong analytical skills, practical ingenuity, and creativity and innovation. The engineer of the future also has to be dynamic, agile, resilient, and flexible; communicate well to diverse, global audiences; be able to master business and management principles; understand and practice leadership principles; hold high ethical standards; possess a strong sense of professionalism; and be a lifelong learner. What are the skill levels of the average male for these characteristics?

These skills somewhat parallel the aptitudes that Mr. Pease alludes to in his article — structural visualization, analytical reasoning, memory for design, and mathematical ability. But much like veterinary medicine, engineering is changing as technology and the information age change our world. Veterinarians no longer need to be big, strong men who handle farm animals. And engineers no longer require a primary aptitude of structural visualization, as did the white males who constituted almost the entire engineering workforce until the mid-1980s and still constitute the vast majority of engineers. In fact, structural visualization is not a characteristic that the NAE identifies as an important skill for the engineer of 2020. Most engineering disciplines no longer even require a drafting class like the one I took in the mid-1970s when I was in college. The advent of the PC and computer programs that produce three-dimensional images changed that.

Women excel in many skills that the NAE projects the engineers of 2020 will require. Women are multitaskers, networkers, communicators, project managers, and problem solvers. Women see things differently than men. Women would not have designed the early versions of VCRs that no one could program. Women would not design a PDA specifically or primarily to fit in a man's breast pocket. Plus, women would not design car airbags that are likely to seriously injure or kill people when it deploys. But 30 women were involved in the design of the Ford Windstar. This very popular van won the five-star governmental award (the highest) for frontal crash tests. In addition, it included such features as square cup holders designed for juice boxes and a reverse sensing system that beeped to warn backing-up drivers of objects in the way. It also had sliding doors on both sides that could be opened by clicks on the key fob.<sup>3</sup> Women think differently.

It doesn't make sense to me to purposely or unintentionally discourage half of the population from pursuing a STEM career, especially when this type of career provides such value for the world's population and can be so satisfying. We are discouraging the female half of the population. One of my coworker's daughters was having trouble with first grade math in a major metropolitan-area public school. This girl's teacher and principal both told her parents, "Don't worry. It isn't important for little girls to do math." Many math- and science-phobic teachers and mothers think math and science are "hard" and thus teach their female students and daughters to avoid math and science. There are also those parents who choose only to pay for higher education for their sons and leave their daughters to pay for and obtain any higher education themselves. The discouragement results in girls who play dumb to be popular and then don't enroll in the advanced math and science tracks in eighth grade that will lead them to STEM careers.

The discouragement continues in the STEM workplace. Here, women who stay in STEM careers do so by battling past or learning to ignore the small insults that occur regularly. (You're pretty good for a woman engineer, you look like a woman engineer, you're pretty smart for a girl, what's a nice girl like you doing in a place like this?) Women even learn



Jill S. Tietjen

to let the large insults that result in a hostile environment slide (being choked on the job site by a client, having a coworker throw a refractory brick at you).

If Larry Summers truly wanted to provoke discussion on the topic of the paucity of women in the STEM workforce, he has succeeded beyond his wildest dreams. The bottom line, however, is that the global economy needs women in STEM careers, and it needs to tap their innovation and creativity and their different way of thinking. Certainly, if women can handle medical, accounting, and legal careers, then science, technology, engineering, and math are also jobs for women!

1. "Response to Lawrence Summers' Remarks on Women in Science," Women in Science & Engineering Leadership Institute, University of Wisconsin, Madison.  
[http://wiseli.engr.wisc.edu/news/Lawrence\\_Summers\\_Response.pdf](http://wiseli.engr.wisc.edu/news/Lawrence_Summers_Response.pdf)

2. "Women in Science: What are the obstacles?"  
[http://whyfiles.org/220women\\_sci/index.php?g=2.txt](http://whyfiles.org/220women_sci/index.php?g=2.txt)

3. "Windstar Moms Team Engineers Parent-Friendly Design"  
<http://www.autoworld.com/news/Ford/ParentFriendly.htm>

As a woman engineer, I have worked for over 25 years to encourage more girls to pursue careers in science, technology, engineering, and mathematics (STEM). I had to stifle my screams and overcome my first inclination to label both Larry Summers and Bob Pease as Neanderthals (or worse) after reading Mr. Pease's column in the April 14 issue of *Electronic Design*. Instead, I decided to apply my analytical reasoning skills (a highly desirable aptitude for pursuing an engineering career) to Mr. Pease's arguments to see if there was any "there" there.

I found that intrinsic aptitude differences between the sexes are not that significant. The scholarly research on the whole question of nature versus nurture has found that gender differences on science and math tests are small and decreasing and that a significant number of complex and not well understood factors, including expectations, influence performance.<sup>1</sup> If genetic and intrinsic aptitude explained why women still constitute such a small percentage of the STEM workforce, how does one explain the increase in female, undergraduate students studying engineering in the U.S.? In 1970, 0.3% of the degrees awarded nationwide went to women. Now women earn almost 20% of the engineering degrees. This is an increase in magnitude of over 60 times. Surely women haven't improved their quantitative skills by this magnitude just in the last 30 years. Factors other than aptitude must account for this result.<sup>2</sup>

The National Academy of Engineering's (NAE) treatise, *The Engineer of 2020: Visions of Engineering in the New Century*, commented on the rapid pace of technological change. The engineering profession will be driven in the next 15 years, this report predicts, by breakthrough technologies including biotechnology, logistics, high-performance computing, materials science and photonics, and nanotechnology. To function in this quickly evolving world, future engineers must not only possess critical thinking skills but also strong analytical skills, practical ingenuity, and creativity and innovation. The engineer of the future also has to be dynamic, agile, resilient, and flexible; communicate well to diverse, global audiences; be able to master business and management principles; understand and practice leadership principles; hold high ethical standards; possess a strong sense of professionalism; and be a lifelong learner. What are the skill levels of the average male for these characteristics?

These skills somewhat parallel the aptitudes that Mr. Pease alludes to in his article — structural visualization, analytical reasoning, memory for design, and mathematical ability. But much like veterinary medicine, engineering is changing as technology and the information age change our world. Veterinarians no longer need to be big, strong men who handle farm animals. And engineers no longer require a primary aptitude of structural visualization, as did the white males who constituted almost the entire engineering workforce until the mid-1980s and still constitute the vast majority of engineers. In fact, structural visualization is not a characteristic that the NAE identifies as an important skill for the engineer of 2020. Most engineering disciplines no longer even require a drafting class like the one I took in the mid-1970s when I was in college. The advent of the PC and computer programs that produce three-dimensional images changed that.



Jill S. Tietjen

Women excel in many skills that the NAE projects the engineers of 2020 will require. Women are multitaskers, networkers, communicators, project managers, and problem solvers. Women see things differently than men. Women would not have designed the early versions of VCRs that no one could program. Women would not design a PDA specifically or primarily to fit in a man's breast pocket. Plus, women would not design car airbags that are likely to seriously injure or kill people when it deploys. But 30 women were involved in the design of the Ford Windstar. This very popular van won the five-star governmental award (the highest) for frontal crash tests. In addition, it included such features as square cup holders designed for juice boxes and a reverse sensing system that beeped to warn backing-up drivers of objects in the way. It also had sliding doors on both sides that could be opened by clicks on the key fob.<sup>3</sup> Women think differently.

It doesn't make sense to me to purposely or unintentionally discourage half of the population from pursuing a STEM career, especially when this type of career provides such value for the world's population and can be so satisfying. We are discouraging the female half of the population. One of my coworker's daughters was having trouble with first grade math in a major metropolitan-area public school. This girl's teacher and principal both told her parents, "Don't worry. It isn't important for little girls to do math." Many math- and science-phobic teachers and mothers think math and science are "hard" and thus teach their female students and daughters to avoid math and science. There are also those parents who choose only to pay for higher education for their sons and leave their daughters to pay for and obtain any higher education themselves. The discouragement results in girls who play dumb to be popular and then don't enroll in the advanced math and science tracks in eighth grade that will lead them to STEM careers.

The discouragement continues in the STEM workplace. Here, women who stay in STEM careers do so by battling past or learning to ignore the small insults that occur regularly. (You're pretty good for a woman engineer, you look like a woman engineer, you're pretty smart for a girl, what's a nice girl like you doing in a place like this?) Women even learn to let the large insults that result in a hostile environment slide (being choked on the job site by a client, having a coworker throw a refractory brick at you).

If Larry Summers truly wanted to provoke discussion on the topic of the paucity of women in the STEM workforce, he has succeeded beyond his wildest dreams. The bottom line, however, is that the global economy needs women in STEM careers, and it needs to tap their innovation and creativity and their different way of thinking. Certainly, if women can handle medical, accounting, and legal careers, then science, technology, engineering, and math are also jobs for women!

1. "Response to Lawrence Summers' Remarks on Women in Science," Women in Science & Engineering Leadership Institute, University of Wisconsin, Madison.  
[http://wiseli.engr.wisc.edu/news/Lawrence\\_Summers\\_Response.pdf](http://wiseli.engr.wisc.edu/news/Lawrence_Summers_Response.pdf)

2. "Women in Science: What are the obstacles?"  
[http://whyfiles.org/220women\\_sci/index.php?g=2.txt](http://whyfiles.org/220women_sci/index.php?g=2.txt)

3. "Windstar Moms Team Engineers Parent-Friendly Design"  
<http://www.autoworld.com/news/Ford/ParentFriendly.htm>



# BOB'S MAILBOX

**Hi Bob:** I see more and more uses of LEDs in place of incandescent lamps every day. However, many of our engineering brethren are not looking at the big picture with these. It would appear that they are not considering the devastating interference that some of these replacement LED (power-supply)

units are creating on the AM radio broadcast bands.

For example: traffic signals. While I was waiting under a red traffic signal, I had a barrage of repetitive static wiping out the AM broadcast station that I was listening to. That is, until the light turned green. This RF buzzing interference had not happened before at this location. Upon closer examination the next day, it appears that (just) the red traffic signal incandescent bulbs were replaced with a load of red LED signal lamps, hence the interference during red signals, and not during the yellow and green incandescent illuminations. (Apparently, some guys have used crude switchers to convert high V to high current, and to hell with the RFI/EMI. Quite unfortunate. /rap)

In summary, more thought should be put into our design projects to ensure that we don't cause problems with other existing technologies, and in this case, we need to be aware of working on LED replacement lamp power-supply solutions that don't cause major interference. (For sure!! /rap)

I doubt if these red LED signals would meet FCC Part 15 regulations, as I would have definitely missed a tornado warning broadcast on that station until I was able to drive away from the offending RF generator. (I'll switch over to AM reception. Here in the Sunnyvale area, there are a lot of LEDs. /rap)

The other item down the pike is the proposed Broadband over Power Line (BPL), which has the potential to derail communications across the board. But that's another topic for another day.

- **John Pavlica** (via e-mail)
- **Pease:** That's a whole other mess. All my ham friends are furious about this proposal.

**Hi Bob:** Just read Jason Cook's inquiry on eyelet usage in pc boards (ELECTRONIC DESIGN, Feb. 17, p. 20). It sent me back to the early '70s when I serviced consumer Hi-Fi equipment. A well-known manufacturer (KLH) produced the first reel-to-reel tape recorder with an integrated Dolby system. Technically, the machine was quite an evolution and sounded excellent. However, the vast majority developed intermittent problems virtually immediately. The KLH Model 41 was plagued by the use of "eyelets" through the pc board to connect upper and lower layers. I've spent many an hour chasing down intermittent connections in KLH Model 41s. All this to say—eyelets? Please no. A plated-through connection is the better way to go. Surely, there was nothing saved by the use of eyelets if reliability was

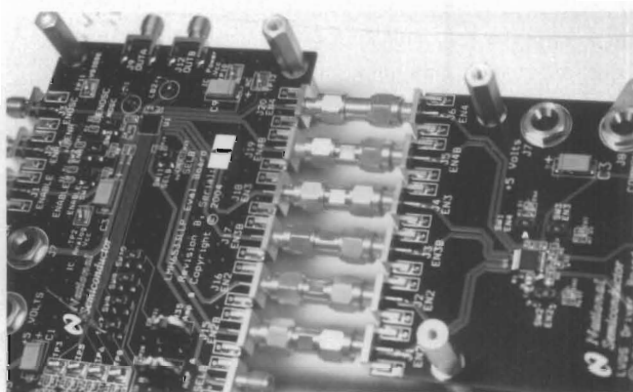

any concern at all. (It is imaginable that a really heavy component might make you wish you had an eyelet to support the heavy weight—in shock conditions—which would, of course cause them to go open! /rap)

- **Geoff Pomeroy** (via e-mail)
- **Pease:** Hi, Geoff, your story is consistent with other people's stories. If I had a board without eyelets, I would just wire a wire through the hole and solder the wire (at least 3/16 in. of it) to the top and bottom foils. Or I would preferably do two of those, in parallel, through adjacent holes. I've done that. I am convinced this is very reliable. If I had a pc board that already had an eyelet, I would solder a wire through the hole (or solder it to the component lead that goes through the hole) and extend it about 1/4 in. away and solder it, top and bottom, to the two foils. The 1/4 in. would act like a strain relief. Is this an adequate fix or "band aid"? It's consistent with what I have seen, but I repaired a lot of my pc boards, and almost none of anybody else's, with eyelets. Philbrick used eyelets, in Malter's SP656, in parallel with shorted (top-bottom) edge connectors, so we would never see any failure. Failures would be unnoticeable. **ED**

Comments invited! rap@galaxy.nsc.com —or: Mail Stop D2597A, National Semiconductor P.O. Box 58090, Santa Clara, CA 95052-8090

**BOB PEASE** obtained a BSEE from MIT in 1961 and is Staff Scientist at National Semiconductor Corp., Santa Clara, Calif.



# WHAT'S ALL THIS NAP STUFF, ANYHOW?

I like to sleep. I like to wake up. But I don't like to wake up at 1:40 a.m. and not be able to get back to sleep for a few hours. Two o'clock, 3, 4... and this lying in bed is not restful. Finally I may get back to sleep at 5 and when I wake up at 7, the newspaper is waiting for me to read it. I'm not off to a good start on the day.

I think I've solved this problem. When I wake up at 2 a.m., I wait for barely 1/2 hour, and if I can't get to sleep, I get up. I read some e-mails or other mail, and I type, and perhaps write a column (as I am doing now). By 5 a.m., I can usually get the newspaper. If I then get a "nap attack" and go back to sleep, that is great.

I can wake up by 7:30 a.m., surprisingly well rested. Trying to get back to sleep at 2 a.m. can be a loser. Big waste of time. Getting up and working, to get sleepy, is not a terrible idea. I don't know why I can't get back to sleep at 2 or 3 a.m. I guess I am rested *just enough* that I can't get back to sleep.

I never have much trouble with jetlag. When I fly at 4 p.m. to Europe, I may fall asleep on the plane, but not get much rest. So by the time I get to London-Heathrow (LHR), I am a little tired. However, by 5 p.m., I get quite sleepy. If I fall asleep then, I might sleep for several hours and then wind up wide awake in the middle of the night! That is the bugaboo of jetlag—not being able to get your sleep/awake cycle into the right phase. So:

(A) If you get sleepy at 5 p.m. on your first day in Europe—go ahead, go to sleep—but set two alarms, as needed, to wake you up after just a couple hours. Then, get up and do the town, and eat and drink, all evening.

(B) Drink is the other part of the solution. Drink lots of beer, or whatever, and stay awake and cheerful until at least 11 p.m., preferably later. Then go to bed. You are then so tired, and well hydrated, and full of alcohol and food, that you can now sleep to morning. This is like taking a phase-locked loop and forcing it to a new phase.

Sometimes I don't get enough sleep during the week. I build up a sleep deficit. When I get to Saturday, I sleep late, and I am still tired. Obviously I need to get another nap.

Once, I was driving down toward work. I was quite sleepy, but I kept awake just fine all the way down to El Camino Real. Then I

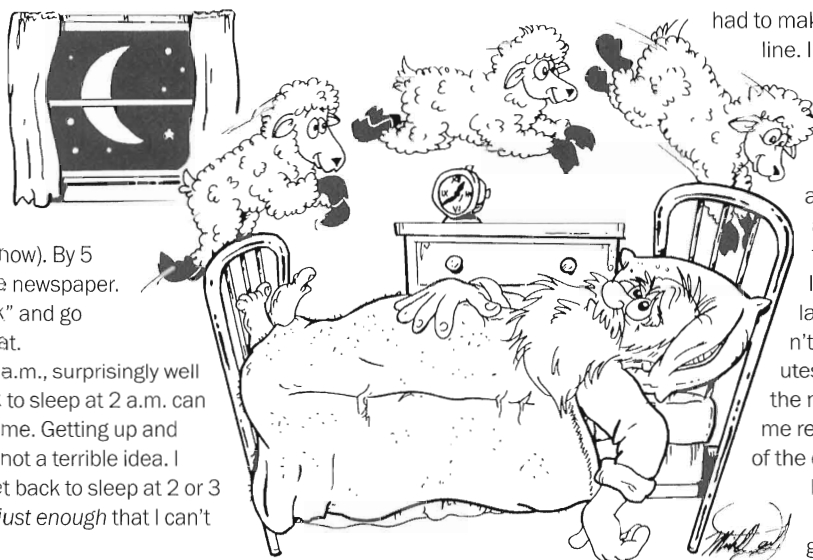

had to make a left turn onto Shoreline. I stopped in one of the two left-turn lanes. A few minutes later, a woman came by and rapped on my window. "Are you all right?" I had fallen asleep while waiting for the green arrow. I figured, I might have to take a nap later in the day—but I didn't. Apparently the few minutes of nap (sitting parked in the middle of the road) kept me rested enough for the rest of the day. I was a bit surprised by that.

As I say in my pretty good book\*, driving while sleepy is pretty dangerous

and comparable in danger to driving under the influence of alcohol. Washing your face with cold water, or taking a snack with caffeine, or singing loudly, may work for a little while. But when these do not work, take a nap. It's dangerous not to.

We've all heard the warning: "If it is very cold, don't go to sleep, or you may never wake up." But this is not necessarily true. Napping when you are only moderately sleepy is probably a good idea. Staying awake until you are exhausted is probably not a good idea, as you may be more prone to chilling when you fall asleep at that stage. **BO**

Comments invited! rap@galaxy.nsc.com —or: Mail Stop D2597A, National Semiconductor P.O. Box 58090, Santa Clara, CA 95052-8090

\*How To Drive Into ACCIDENTS—And How NOT To, page 277, Pease Publishing, at www.transtronix.com.

BOB PEASE obtained a BSEE from MIT in 1961 and is staff scientist at National Semiconductor Corp., Santa Clara, Calif.



# BOB'S MAILBOX

**Dear Bob: I have an odd problem.** Early British cars used an electromechanical vibrating regulator to supply  $-10\text{ V}$  to the gas gauge from the 12- to 14-V battery (“positive ground”). The current demand is low, probably 1 A would do. I have been, so far, unsuccessfully searching for a  $-10\text{-V}$  regulator in a TO220

package. A positive regulator would be trivial to find. I did find an MSK part, but they wanted \$100. New mechanical devices are so poor that many are DOA and others have a short life. They cost about \$25.

- **Gene Mallory** (via e-mail)
- **Pease:** Hello, Mr. Mallory. Look up the LM337 and see if it won't do your job. It will need  $124\ \Omega$ , 1%, and  $866\ \Omega$ , 1% (or  $100\ \Omega$  and  $700\ \Omega$ , 1%). And there you have a  $-10\text{-V}$  output. It will also want 10 or 20  $\mu\text{F}$  of output bypass capacitance for loop stability and to suppress transients. And if the input source is far away, it will need a couple of microfarads at the  $-14\text{-V}$  input. And the case of the LM337T will be at  $-14\text{ V}$ . So, you might need an insulator to couple it to your heatsink. The going price in Akihabara, in Tokyo, is about 79 cents, or 89 yen. They are also stocked by Digkey or similar distributors. (You DID ask the right guy. I designed the LM337T about 28 years ago—and it's still in production. SOLID. /rap)

**Dear Bob:** While reading your conditioning on the stairs article (ELECTRONIC DESIGN, March 3, p. 20), I was reminded of a friend whose mom conditioned him and his siblings indoors. She put backpacks filled with rocks on her children, then marched them through the house day after day. When she thought they were ready, she marched them out of Lithuania to freedom back in the forties. I think I must have just sat there with my jaw dropped while Ivar told me the story of how he walked to America. Gives homework a whole new meaning.

- **Peter Nord** (via e-mail)
- **Pease:** Hello, Peter. Wow, I am impressed! I read the story of a man and his son who walked from eastern Poland across Europe in the 1930s. When they got to France, the man died, but the son kept going to get on the boat to the U.S. Same idea and also very impressive!

**Dear Bob:** I never really thought about using the one flight of stairs in my house for conditioning—although I generally climb the steps at work two at a time with only a light grasp of the handrail, as I don't want the safety geeks to get upset. (Here at NSC, some “safety geeks” put up a sign to “always use the handrails to avoid accidents.” After I see that sign, I never use the handrails! I always run up and down stairs. But I rarely run down two steps at a time. /rap)

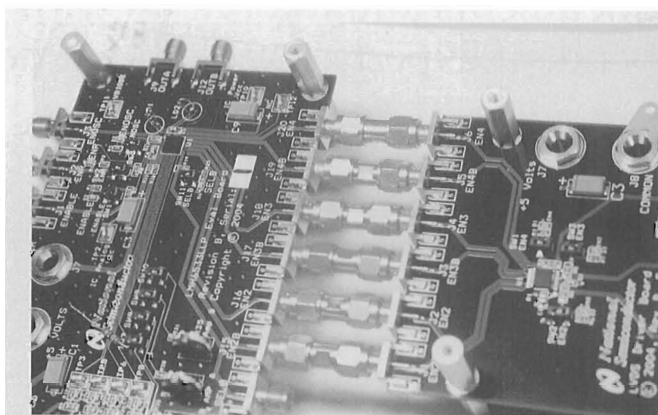

I like bicycling and am convinced this will help build my legs for the hills around here. However, my comment is more aimed at the maximum heartrate issue. I always heard 220 minus your age is an absolute maximum. (You might be quite right, but 200  $-x$  is a good recommended maximum rate. /rap)

Several years ago, after taking a spinning class at a gym and seeing my heartrate hit 175 bpm (at the age of 50), I asked the instructor about this max heartrate thing. She replied that 220 minus age was a good rule of thumb, but people who have regularly exercised for a number of years can usually attain higher readings than the formula predicts.

In case you think I'm just patting myself on the back, I also believe that like any rule of thumb, individual differences exist regardless of other factors. Thanks for the tip on the stairs. I'll probably incorporate it in my own workouts on days off the bike.

- **Barry Cantor** (via e-mail)
- **Pease:** Wow. I've done 160 bpm after a long uphill pull, hiking at the age of 60, and I thought I was pushing it. When I walked away from all my buddies back in 2000, at 18,000 ft, I did not have any measure of how fast my heart was beating, but I was definitely limited by how much air I could bring in through my NOSE. I was probably near 160. **BO**

Comments invited! rap@galaxy.nsc.com —or: Mail Stop D2597A, National Semiconductor P.O. Box 58090, Santa Clara, CA 95052-8090

**BOB PEASE** obtained a BSEE from MIT in 1961 and is Staff Scientist at National Semiconductor Corp., Santa Clara, Calif.



# WHAT'S ALL THIS DOCTORING STUFF, ANYHOW? (PART 4)

Usually, I write my own columns. But recently I received a letter that was just too good to include in a “Bob’s Mailbox.” So I decided to make it the latest installment in my series on self-doctoring. Thank you, Mr. Kraus, for taking the time to share your hard-earned insights with our readers. /rap

**Dear Bob:** I had carpal tunnel, bipolar, migraines, body aches, leg cramps, and crippling prostatitis. My doctor tried to prescribe (respectively) surgery, drugs, nothing, nothing, nothing, and lots of sex. Given the progressive patterns of my symptoms—as I experienced them—I suspected a food-related systemic degenerative problem. And I wanted guidance from my doctor. My doctor would hear nothing of it, because “food intolerances are rare.” But he warned me about a teensy elevation in my cholesterol.

Well, inspired by your self-doctoring articles (ELECTRONIC DESIGN, Sept. 30, 2002, p. 110; Oct. 14, 2002, p. 86; April 12, 2004, p. 18), I studied food intolerances on my own. And to my joy, I have successfully treated these problems and more by eliminating any source of gluten. I used to be derisive of diets like this. Now I’m on the other end of the derision—karmic, eh?

There is a lot of public doubt on the subject. I wouldn’t have believed it myself if I lacked the scientific background to read the research or keep an engineering journal of my symptoms as I tried the diet. My doctor is still cool to the idea, so I finally pestered an out-of-state friend (an MD) for support. He recently sent me this note:

*“No one but one of us who has suffered from gluten intolerance can really understand what you have been through for diagnosis, or the victory you have won. Don’t forget, you already diagnosed this yourself, and just asked me for information to confirm your own hypothesis. You cured yourself!*

*“It brings me huge joy to hear that you have healed and found more joy in your life, and are not a victim of your genetics and well-meaning but not-well-informed doctors.*

*“I saw a patient who I and all her doctors had thought had MS for 15 years, who was dying by inches, have a dramatic turnaround last month on a gluten-free diet. I wept that I had missed her food intolerance. You owe me nothing. You are a friend. Just be alert, and someday you can pass it forward.”*

Self-doctoring seems to be the rule with gluten intolerance. U.S. doctors have been taught that it is only a rare childhood disease. But 21<sup>st</sup> century research proves that gluten intolerance is very common and has many symptoms that are easily mistaken for other conditions. Gluten’s strong contributions to other conditions such as diabetes and depression are only recently under study. Conventional blood tests have been recently shown by Kenneth



Fine, MD, ([www.enterolab.com](http://www.enterolab.com)) and others to produce more false negatives than true positives. Thus, many seriously sick patients have been told that tests show that nothing is wrong with them.

Doctors have hundreds of patients and only get the odd 15 minutes here and there to talk with you, but you are with yourself all of the time. You ought to quarterback your own health care. Lists of gluten intolerance symptoms, tips for diagnosis, and links to research papers and Celiac sites are available at [www.members.cox.net/harold.kraus/gluten.htm](http://www.members.cox.net/harold.kraus/gluten.htm). With sincere gratitude, Bob, for your self-doctoring essays,

- **Harold Kraus Jr.** (via e-mail)
- **Pease:** The occurrence of Celiac disease used to be estimated at a few ppm. Now it’s recognized as around 1%. If you have symptoms, and no cause, consider a three-week vacation from gluten. Thanks, Harold. /rap **ED** **ED Online 10410**

Comments invited! [rap@galaxy.nsc.com](mailto:rap@galaxy.nsc.com) —or: Mail Stop D2597A, National Semiconductor P.O. Box 58090, Santa Clara, CA 95052-8090

**BOB PEASE** obtained a BSEE from MIT in 1961 and is staff scientist at National Semiconductor Corp., Santa Clara, Calif.





## BOB'S MAILBOX

**Dear Bob:** This is a general question about TO-220 packages. I am finding MOSFETs available in TO-220AB packages that claim to have continuous ratings of 120 A. I can believe the die can take it if heatsinked well. But can those skinny 0.044-in.<sup>2</sup> wires take that kind of current? (I think they are tin plated

copper lead frames unless they are some kind of superconducting alloy.) The copper wires in my house are 14 gauge and are only rated for 15 A, and they are bigger. And what about the die bond wires? Is someone pulling my leg or what? Is this a new form of specsmanship?

- **Ed Ganshirt** (via e-mail)
- **Pease:** Hello, Ed, #14 copper wire is rated to fuse at 160 A (per the CRC Handbook). So there's a safety factor of 10, for surges. But a TO-220AB's lead is just 18 mils thick by 45 mils wide, tapering to 28 mils (min), and the datasheets say it's good for 75 A? I can't believe that! Let's try it! Stand back!

**Hi Bob:** I am writing to express my concern over what I regard as premature adoption of lead-free soldering in our industry. There seems to be an almost lemming-like quality in the rush to adopt this technology. (Yeah. /rap)

I have yet to see any concrete data regarding manufacturability and reliability, although the consensus appears to be that both are going to get worse. Would you want to rely on a defibrillator that used lead-free solder? (No! /rap)

- **Ken Neltner** (via e-mail)
- **Pease:** Hello, Ken. NSC's MIL AERO group is keeping the lead-based solder, that is solder-dipped onto the leads of hi-rel parts. Some examples are LM108AH-883 or MIL-38510 parts for military and space applications. Similar industrial parts (LM108AH) will have solder-coated leads without the element lead. It will not be a straight tin solder, as many other IC makers are doing, but we will have a tin-silver-copper coating that is dipped on. And that is apparently better for whisker-free manufacturing. But at any time, if you need the highest reliability you can get—such as for pacemakers or defibrillators (even with inexpensive plastic-packaged parts)—you can use conventional solder with lead. That is, if and when you can get it. That will prevent the tin-whisker problem. Talk to your favorite solder maker, and get his opinion. Okay? Good question, and thanks for asking.

**Hey Bob:** Yesterday, I took a break from the breadboard of my latest design to graze through the new copy of *Electronic Design*. Dick Weiner's letter was nice to see (ELECTRONIC DESIGN, June 23, p. 18.). I'm not the only person who wants to actually see his designs work. Makes it a lot easier to defend yourself in the meetings.

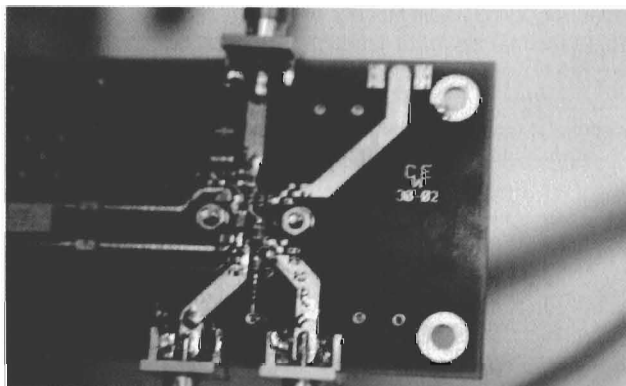

What I was taking a break from was installing eight SOT-23 transistors onto a 24-pin Aries SOIC board. They work just fine, if you have the patience to solder them into place. (Actually, a couple of these are gonna be used as diodes. Thanks to you for that.) You can use the transistors, diodes, Zeners, and such that you're actually going to use in production. (True, but the adapter board does add a little bit of stray capacitance and inductance. Gotta watch out for that! /rap)

I design voltage regulators and similar circuits for my company's line of heavy-duty automotive alternators, so I don't have to deal with speeds above the clock on a microcontroller. Therefore, speed is not an issue. These Aries SOIC boards can even be used for five-pin SOT-23 parts. Takes a little imagination and patience, but they work just fine for the little 7101s and 7301s.

- **Edward Craig** (via e-mail)
- **Pease:** Glad you're having fun with the tiny circuits, Edward.

**OLD PHILBRICK AMPLIFIERS** • My old friend Tom Decker has some old Philbrick Amplifiers that he wants to be selling soon, such as K2-Ws and USA-3s. You could look on eBay or write to him at New Dimensions, 978 West County Road I, St. Paul, Minn. 55126-1315. **EO** **ED Online 10905**

**Comments invited!** rap@galaxy.nsc.com —or:  
Mail Stop D2597A, National Semiconductor  
P.O. Box 58090, Santa Clara, CA 95052-8090

**BOB PEASE** obtained a BSEE from MIT in 1961 and is Staff Scientist at National Semiconductor Corp., Santa Clara, Calif.



## BOB'S MAILBOX

**Hi Bob: Does anyone breadboard** circuits anymore? In the good old days, just a few years ago, you used to draw circuit diagrams in your articles that looked like something a college professor would put up on a white board. We design engineers would all run out to the lab and try it out in a couple of hours.

I always seemed to get more out of actually trying out my more complex circuits than from simulating them.

However, today a lot of the newer, exciting ICs come only in such small packages that even a neurosurgeon would be hard pressed to hook them up. Have you ever tried to solder wires to a quad op amp in a 14-pin, small-outline IC (SOIC) package? Have you seen the packages that these three-pin precision voltage references come in? If you sneeze—game's over? I'm all for miniaturization, but not in the breadboard stage. Not all of us are working in the gigahertz range where lead length is critical. Have you ever soldered #36 wire to one of these parts and then to an old-fashioned DIP socket—so that you could wire wrap to it?

I recently got a sample kit of op amps from one of the major IC vendors. It has some really neat parts. The largest package was an eight-pin SOIC. To add another level of complexity, they included tape and reel parts. I mean, come on, how do you build breadboard circuits with fly-spec parts? (*With perseverance—or with adapters.* /rap) Are there any inexpensive chip carriers that convert these parts to fit into an old-fashioned DIP socket? Does anyone out there have a solution, other than laying out custom pc boards every time you want to breadboard a circuit?

- **Dick Weiner** (via e-mail)
- **Pease:** Yes! Let me find you the standardized answer from Paul Grohe. DigiKey carries them. For non-gigahertz applications, these are good, and they have solder-mask, so they connect up and don't short out.
- **Paul Grohe:** Hi, Dick. For SO-8/14-to-DIP conversion, <100 MHz, the Aries "Correct-A-Chip" series is what I use. The adapters seem pricey at first, but because they are solder masked, they are easier to solder and desolder and can be reused several times ([www.arieselec.com/products/correct.htm](http://www.arieselec.com/products/correct.htm)). Models 08-350000-10 and 14-350000-10 are available from DigiKey and Mouser. I have used these well into the hundreds of megahertz with op amps (with the

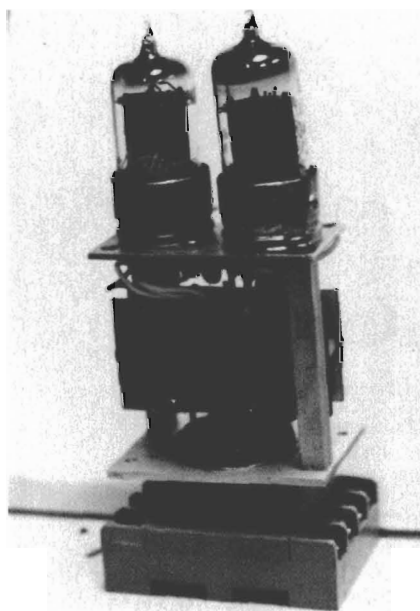

expected peaking), but I would not try them on fast, high-current switchers or other LC RF-critical applications where extra lead inductance and capacitance could be lethal to the circuit. But for low-power, low-speed apps, they are all but invisible.

For SOT-23, SC-70, MSOP-8, and other nasty little "transistor" packages, the Capital Advanced Technologies "Surfboards" can be used ([www.capitaladvanced.com](http://www.capitaladvanced.com)). These adapt SOT-xxx to a 0.1-in. spacing SIP. They do not have solder mask and don't tend to last as long, but they are a bit cheaper. They are available from DigiKey, Newark, Fry's, and Jameco. By the way, you can "stretch" an SC-70-3 onto a SOT-23-3 footprint. So the SOT-23 adapter can do "double-duty" as an SC-70 adapter, too.

**Hi Bob:** I tried your stair-climbing idea (*ELECTRONIC DESIGN*, March 3, p. 20) this morning instead of my usual Sunday morning outdoor downhill/uphill plod, as it was raining a bit here near Seattle, Wash. (Imagine that!) I decided to start with 50 laps and it took me about 20 minutes. Nice little workout. (*Fifty is a pretty good start. When I was out of shape, I did 65—which is lousy—but it was a start.* /rap) The only comment that I have is that I prefer a little 10-minute cool-down walk afterwards, just to gather my wits. Thanks for the suggestion.

- **Dave Gerstenberger** (via e-mail)
- **Pease:** My preference is to just lie there, but I guess I am used to that. While I am lying there, I can count my pulse rate (up near 150 bpm?), then wait two minutes and see if the rate dropped a lot. **ED Online 10521**

**Comments invited!** rap@galaxy.nsc.com —or:  
Mail Stop D2597A, National Semiconductor  
P.O. Box 58090, Santa Clara, CA 95052-8090

**BOB PEASE** obtained a BSEE from MIT in 1961 and is Staff Scientist at National Semiconductor Corp., Santa Clara, Calif.



**Pease**PORRIDGE

**BOB PEASE**, *Contributing Editor*

• • • rap@galaxy.nsc.com

# WHAT'S ALL THIS FLOOBYDUST STUFF, ANYHOW? (PART 14)

**This year I'm going to start off with magazines:** It is well known that huge (astronomical!) quantities of magazines—especially *National Geographic*—have been stored in a million attics across the U.S. This raises the center of gravity of the house and the Polar Moment of Inertia of the whole Earth.

Physicists have predicted that the Earth will wobble excessively, its rotation will slow down to a critical speed, and then the Earth will fall out of its orbit sometime in the first half of this century. It is not known if this will happen earlier than the demise of the Social Security Trust Fund, or later—or simultaneously?

**SCIENCE FICTION** • My friend Bill Bernardi recommended to me a good science fiction book by Eric Harry: *Society of the Mind*. Bill wrote, “Hey Bob, I just read... this book. It reminded me often of you.... It's about this young genius who can't handle the real world, so he buys an island and stocks it with the best and brightest people of the time, from all fields... pays them millions of bucks.... His philosophy is that the digital world of computer technology is a dead end and must evolve in analog form to continue to grow. So he used neural networks and fuzzy logic to let the analog computer teach itself how to grow bigger and better and smarter....”

I read it, and I agree that this was a fascinating, fanciful, and enjoyable story about how one brilliant man could plan one big computer that could build itself bigger and better—until some very interesting things happened. I'm going to buy a few second-hand copies of this 1997 book to give to friends.

**SCIENCE HYPERFICTION** • I had to cobble up a simple clock and a 74C163N counter to make that stair-step waveform for the “conditioning” column (*ELECTRONIC DESIGN*, March 3, p. 20). So I grabbed a solderless breadboard, and I lashed up the circuit—for the first time ever. All the wires were flaky and confusing (not any choice of color, for a given length of wire). The resistors were quite wobbly and flaky. The insulating space between adjacent components was marginal. I got it to work (just barely), but the connections were not reliable. I do not like solderless breadboards. This was a setup—an experiment kit for students—that Forrest Mims sent me. I like his experiments, but I just don't like using a solderless breadboard to connect them. My favorite programming language really is solder. The experiment kit, Learning Lab Model 28-280, costs about \$60 at any Radio Shack ([www.radioshack.com](http://www.radioshack.com)).

**GOOD NEWS!** • I told you a few years ago that across the world, all makers of polystyrene had stopped making the materi-

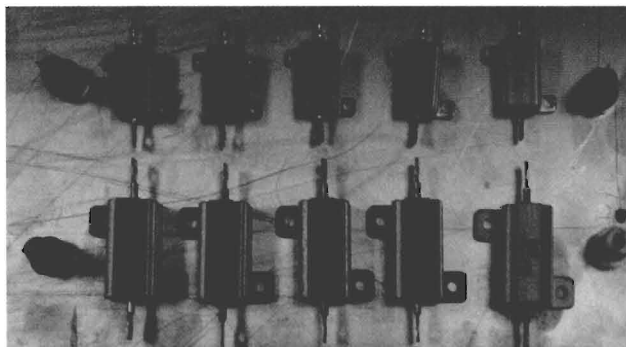

al, and capacitor makers were going to run out of polystyrene. I have been able to use polypropylene for almost all of my precision capacitor needs, with no degradation of accuracy. But now in the U.K., there is a company selling polystyrene capacitors. If you can tell the difference between polystyrene, polypropylene, and any other kind of “poly” caps, you might want to buy some polystyrenes from LCR Capacitors (EU) Ltd. Unit 18 ([www.lcr-capacitors.co.uk](http://www.lcr-capacitors.co.uk)).

**DOCTORING, PART 4-B** • A friend said that his daughters once got really sick with strep throat. After treatment with antibiotics, they got better quickly and went back to school. But shortly, they got sick again, and cured again, and sick again, and again. The doctor tried to figure out how. He tested the mother—was she a carrier? No. Neither were the father and teacher. The MD was stumped—but not the triage nurse. She had their dog tested, and the dog was the carrier. After the dog was treated, the problems went away. (One clue was that the son did not get sick, and the son did not play kissy-poo with the dog.) You can't expect a doctor to know everything. We don't want to be unfair about that. We have to help. **ED** **ED Online 10630**

**Comments invited!** rap@galaxy.nsc.com —or: Mail Stop D2597A, National Semiconductor P.O. Box 58090, Santa Clara, CA 95052-8090

**BOB PEASE** obtained a BSEE from MIT in 1961 and is staff scientist at National Semiconductor Corp., Santa Clara, Calif.



# BOB'S MAILBOX

**Dear Bob:** I'm running into a head-scratcher. I am working on a 2- $\mu$ A current source (pnp transistor plus sense resistor in the emitter lead, and an op amp to control the pnp's base so the voltage across the sense resistor is constant) with as much compliance to use as much of the 5 V as I have available.

(Constancy of current is important but I don't care too much whether it's exactly 2  $\mu$ A as long as it doesn't have much temp-co/drift.)

But I've only found one pnp transistor (PN5138) with any beta specs for collector currents that go down that low. (The PN5138 has—I saw—a guaranteed spec of 50 minimum at 100  $\mu$ A. I did not see any guaranteed spec at 1  $\mu$ A. This transistor is from the Process 66, which is not nearly as high beta as process 62. Good beta at low currents like 1  $\mu$ A is a characteristic—not a guaranteed spec. /rap)

Any idea why? I can see the manufacturers wanting to test/characterize beta at the high end, but why are they leaving off the low end? (It was very uncommon, even 20 or 30 years ago, to see guaranteed specs for beta at 10, 1, 0.1, 0.01, and 0.001 mA. Almost nobody wanted to pay for that. The 2N930s and 2N2484s were npn types, and they were fully specified—at high prices. /rap) Nobody seems to support discrete small-signal bipolar devices anymore. (They never did want to. If you wanted to buy 2N4250s, 2N2605s, or similar pnp devices in mil-spec format, for \$20 to \$40, you could do it. But for your application, just buy some pnp transistors with beta = 200 min at 1 mA. All modern high-beta pnp types will have good beta hold-up at low currents. Get something like the old 2N4250, PN4250, 2N2605, or something similar. If you buy them at Fairchild, they would be anything with high beta such as 300 min at 1 mA, or 250 at 100  $\mu$ A, and they would be from Process 62. That was what they were called when NSC made them. /rap)

I'd use a PFET instead of a pnp, but I'm told FETs begin to leak at high temps with  $V_{GS} = 0$  (e.g. for NFET, 2N7000 specs  $\leq 1 \mu$ A at 25°C,  $V_{GS} = 0$ , and  $\leq 1$  mA at 125°C,  $V_{GS} = 0$ ). And I don't have enough voltage available to apply a reverse bias to  $V_{GS}$ . Any thoughts?

- **Jason Sachs** (via e-mail)
- **Pease:** FETs are not guaranteed to not leak, but they certainly are not guaranteed to leak. The manufacturers just don't want to test below 1  $\mu$ A of leakage, as that takes time, which they hate to waste. Those Process 62s will make you happy.

**Dear Bob:** I was looking at some back issues and I came across your column on the selection of tubes in a Philbrick K2-X (ELECTRONIC DESIGN, Oct. 18, 2004, p. 16). It made me recall an experience of mine. Way back in the middle of a long-gone centu-



ry, I was designing a VHF television tuner. I was using a dual tube, I believe a triode-pentode, specified by the manufacturer for that purpose. We used a major brand, adjusted the circuit, and found that it would work properly with any tube they sent us.

Then we tried another, equally reputable brand. No go. They did not work properly. Both were specified for tuners. They had the same published specs. But the specs defined only the operation of each section. They did not specify the physical layout. It turned out that the orientation of one section was the same for both companies. But the orientation of the other section was different. This caused a difference in the mutual inductance between the elements of one and elements of the other. At 200 MHz, mutual inductance was crucial. (Uh, yeah! /rap)

This indicates the danger of relying on specifications that cover only the major requirements of a product. These are adequate for most applications but omit "minor" details that may be crucial for your particular application. On occasion I have encountered the same problem with mil-spec integrated circuits and generic prescription drugs.

- **Matthew W. Slate** (via e-mail)
- **Pease:** You're exactly right, Matthew. There are many factors that are not trivial. **EO**

Comments invited! rap@galaxy.nsc.com —or: Mail Stop D2597A, National Semiconductor P.O. Box 58090, Santa Clara, CA 95052-8090

**BOB PEASE** obtained a BSEE from MIT in 1961 and is Staff Scientist at National Semiconductor Corp., Santa Clara, Calif.



**Pease**PORRIDGE

**BOB PEASE**, *Contributing Editor*

• • • rap@galaxy.nsc.com

# WHAT'S ALL THIS TYPING STUFF, ANYHOW?

**In the old days**, it was so easy to try to type “3M” to get 3 MΩ in a Spice program, and of course you got 3 mΩ. A typo error can really waste a lot of time! Typing was a large part of our job as a means of communicating to a computer. These days, there are still many things to type, in addition to just typing

e-mails. I type these columns and I write replies to people who send me e-mails.

When I was a kid of about 10, my mother got a couple of instruction books and started to teach me to type on her big upright Royal. It was not easy for a kid to learn, but not too bad. I never did achieve the skill to type a paragraph without errors. I kept making an error and going back and restarting. In those days, we didn't have any “error correction.”

I was supposed to be doing touch-typing without looking at the keys. Maybe I did almost learn that, but over the years, I've noticed that I have to peek at the keys for much of my work. Of course, if I just have to back up a couple strokes and then insert an s, I don't have to look at the s. But when I was typing at my computer in my dining room, I discovered that when it got dark, I had to turn on the lights to type. I'm not a very good typist, nor fast, but I can type about 20 or 30 words per minute after making corrections.

When I type, I usually keep my left fingers at the proper home positions, “asdf.” But my right hand is more free to range around, as I have to be prepared to hit the backspace or delete keys or (with my right thumb) the left-click. My right middle finger has to be busy, pushing around the tiny red joystick on my laptop, in lieu of a mouse. So my ability to touch-type has been further wrecked by the requirements for word processing. My mother would be horrified! But it works.

Anyhow, I have learned to recognize quickly when I type a mistake. With modern word processing, I find it easy to go back a couple of spaces and make a correction almost instantly, and without any need for thinking or reading what I have typed wrong. That saves time.

I started out word processing on a Coleco Adam, and its daisy-wheel printer was far superior to most cheap dot-matrix



printers of its day. The Friday I bought that Coleco Adam, I was asked if I could write a 2000-word story about temperature sensors. “When do you want it?” Tuesday. “Yeah, I think I can do it.” I had enough basic facts, and I cobbled together enough text to mail in on Tuesday.

I graduated to PC Write Lite (Quicksoft) on an old IBM PC. PC Write really did have some nice features.

You could use PF8 to convert uppercase to lowercase, and vice versa. This was very handy if you had inadvertently hit the caps lock, and typed a lot of stuff as caps, by mistake. I miss that. Later, I graduated to an IBM ThinkPad T42. I'm still not that good a typist. On the other hand, I did wear smooth the right hand of the space bar. I almost wore it out in three years. I typically type about 1 Mbyte in a year—various papers, columns, e-mails, and replies...

I've noticed that a good typist will type an “@” with the ring finger of the left hand. But most computer experts (and many engineers) will hit the shift with their left little finger and reach over with the right index finger to hit the “@.” No good typist would do that. But I usually do. It doesn't really slow me down much. To this day, many engineers still use a hunt-and-peck method. Do schools teach typing these days, or do engineers just have to learn as they go? I'm not sure. It's not the same thing as writing software or playing computer games. **EO**

**Comments invited!** rap@galaxy.nsc.com —or:  
Mail Stop D2597A, National Semiconductor  
P.O. Box 58090, Santa Clara, CA 95052-8090

**BOB PEASE** obtained a BSEE from MIT in 1961 and is staff scientist at National Semiconductor Corp., Santa Clara, Calif.



**Pease**PORRIDGE

**BOB PEASE**, *Contributing Editor*

• • • rap@galaxy.nsc.com

## BOB'S MAILBOX

Dear Bob: This is a general question about TO-220 packages. I am finding MOSFETs available in TO-220AB packages that claim to have continuous ratings of 120 A. I can believe the die can take it if heatsinked well. But can those skinny 0.044-in.<sup>2</sup> wires take that kind of current? (I think they are tin plated copper lead frames unless they are some kind of superconducting alloy.) The copper wires in my house are 14 gauge and are only rated for 15 A, and they are bigger. And what about the die bond wires? Is someone pulling my leg or what? Is this a new form of specsmanship?

**Ed Ganshirt (via e-mail)**

Pease: Hello, Ed, #14 copper wire is rated to fuse at 160 A (per the CRC Handbook). So there's a safety factor of 10, for surges. But a TO-220AB's lead is just 18 mils thick by 45 mils wide, tapering to 28 mils (min), and the datasheets say it's good for 75 A? I can't believe that! Let's try it! Stand back!

**Hi Bob:** I am writing to express my concern over what I regard as premature adoption of lead-free soldering in our industry. There seems to be an almost lemming-like quality in the rush to adopt this technology. (*Yeah. /rap*)

I have yet to see any concrete data regarding manufacturability and reliability, although the consensus appears to be that both are going to get worse. Would you want to rely on a defibrillator that used lead-free solder? (*No! /rap*)

**Ken Neltnor (via e-mail)**

**Pease:** Hello, Ken. NSC's MIL AERO group is keeping the lead-based solder, that is solder-dipped onto the leads of hi-rel parts. Some examples are LM108AH-883 or MIL-38510 parts for military and space applications. Similar industrial parts (LM108AH) will have solder-coated leads without the element lead. It will not be a straight tin solder, as many other IC makers are doing, but we will have a tin-silver-copper coating that is dipped on. And that is apparently better for whisker-free manufacturing. But at any time, if you need the highest reliability you can get—such as for pacemakers or defibrillators (even with inexpensive plastic-packaged parts)—you can use conventional solder with lead. That is, if and when you can get it. That will prevent the tin-whisker problem. Talk to your favorite solder maker, and get his opinion. Okay? Good question, and thanks for asking.

**Hey Bob:** Yesterday, I took a break from the breadboard of my latest design to graze through the new copy of *Electronic Design*. Dick Weiner's letter was nice to see (electronic design, June 23, p. 18.). I'm not the only person who wants to actually see his designs work. Makes it a lot easier to defend yourself in the meetings.

What I was taking a break from was installing eight SOT-23 transistors onto a 24-pin Aries SOIC board. They work just fine, if you have the patience to solder them into place. (Actually, a couple of these are gonna be used as diodes. Thanks to you for that.) You can use the transistors, diodes, Zeners, and such that you're actually going to use in production. (*True, but the adapter board does add a little bit of stray capacitance and inductance. Gotta watch out for that! /rap*)

I design voltage regulators and similar circuits for my company's line of heavy-duty automotive alternators, so I don't have to deal with speeds above the clock on a microcontroller. Therefore, speed is not an issue. These Aries SOIC boards can even be used for five-pin SOT-23 parts. Takes a little imagination and patience, but they work just fine for the little 7101s and 7301s.

**Edward Craig (via e-mail)**

**Pease:** Glad you're having fun with the tiny circuits, Edward.

OLD PHILBRICK AMPLIFIERS

My old friend Tom Decker has some old Philbrick Amplifiers that he wants to be selling soon, such as K2-Ws and USA-3s. You could look on eBay or write to him at New Dimensions, 978 West County Road I, St. Paul, Minn. 55126-1315.

Comments invited! rap@galaxy.nsc.com —or:  
Mail Stop D2597A, National Semiconductor  
P.O. Box 58090, Santa Clara, CA 95052-8090



# WHAT'S ALL THIS TOASTER STUFF, ANYHOW?

Well, I never owned a toaster, but I have owned several kinds of toaster ovens. A long time ago, I had a good GE one. But then Black & Decker took over GE, and while the toaster ovens performed okay, they showed me poor reliability after a while. They would fail shortly after the warranty ran out, and I'd buy

another. I soon got tired of this. They would either quit open-circuit, or the heating element would go gablooney. (That's a technical term.) Either way, they were unrepairable. My wife volunteered to buy the next one.

She went out and bought a new kind of toaster oven from Black & Decker. When she got it home, it didn't work at all. She decided to try a DeLonghi toaster oven. It looks handsome, and it seemed to have many nice features. It's a model AS960, now about two years old, and it does seem to be reliable. The only problem is that it doesn't toast.

Whether you put in two pieces of bread, or six, it takes forever to get them even light brown. I have to put it through two "Dark" cycles to get it even light brown. I measured the power, using my watt-meter (*ELECTRONIC DESIGN*, May 13, 2002, p. 86), and it was barely 1200 W on our 112-V line. Not very healthy.

I decided to add a booster transformer to get it up to over 1400 W. I went down to Halted Specialties Corp., which had many small transformers—and a few BIG HEALTHY power transformers. Surely one of them would put out 10 extra V! I got a few and doped out which windings would do what. I wired three 115-V primaries in parallel and three 3-V secondaries in series. Lovely (surplus) transformers—this rig would put out 14 A and stay cool.

I set up some standard bagel pieces. I set up my wattmeters and voltmeters all around the toaster, along with the transformers. Sure enough, adding the boost transformers kicked up the power from 1260 to 1470 W. The heating elements got red. I prewarmed the toaster for three minutes, let it cool for one minute, and toasted some bagel pieces at 1460 W for exactly three-and-a-half minutes.

I let the toaster cool off for one minute and toasted a matched set of bagel pieces at 1260 W—to get them exactly the same color. And the time was—exactly three-and-a-half minutes. H'mmm. I'm not sure what went "wrong," but I'm glad I ran the experiment very carefully. Maybe this weekend I'll buy a loaf of white bread and repeat the experiment—1260 W, then 1460, 1260, 1460 W... I may learn a trick.

So if you buy a piece of consumer electrical equipment, don't be surprised at anything. Don't even be surprised if you have to add a little helper to Ohm's Law.



The bagels toasted at 1460 W for 3.5 minutes are on the left; at 1260 W for 3.5 minutes on the right.

**RELATED STORY** • There was a guy, George Gobel, who wanted to decrease the time for starting his charcoal broiler. He tried several kinds of boosters, chemicals, etc. Finally he hit on the ultimate charcoal starter: LOX. He would apply a small flame under the charcoal. Then from the end of a 10-ft pole, he would pour a few gallons of liquid oxygen over the charcoal. His camcorder could not record any actual details, as the flame was too bright. But in three seconds, the charcoal was hot enough to broil meat. Think of all the time you have wasted trying to get charcoal started. Now you will never waste more than three seconds! There is one minor drawback: If you use a cheap metal grill, it will burn right through. You may find that a porcelain or ceramic grill lasts longer... Hey, maybe I should do that with my toaster! The URL is [www.doeblitz.net/ghg/](http://www.doeblitz.net/ghg/). **ED**

Comments invited! [rap@galaxy.nsc.com](mailto:rap@galaxy.nsc.com)  
—or add your comments online at ED Online 10940  
—or: Mail Stop D2597A, National Semiconductor  
P.O. Box 58090, Santa Clara, CA 95052-8090

**BOB PEASE** obtained a BSEE from MIT in 1961 and is staff scientist at National Semiconductor Corp., Santa Clara, Calif.



# WHAT'S ALL THIS WIRELESS STUFF, ANYHOW?

**As Jaye P. Morgan sang 50 years ago**, “They all laughed at Wilbur and his brother, when they said that man could fly. They told Marconi, wireless was a phony, it’s the same old cry.”\* For over 60 years, I have been enjoying many wireless things. But these days, people think “wireless” is a great *new* deal.

If somebody invents a wonderful new system with electromagnetic radiation and digital coding, it must be good. “Radio” is obsolete. “Wireless” is wonderful.

Just this morning, I heard Disney head Michael Eisner say that before 1948, there were only three major movie studios, and no television, for entertainment. He seemed to have no inkling that there were several large (and lively) radio networks broadcasting music, news, drama, and entertainment all around this country (and around the world) many years before World War II. People don’t seem to pay no respect to radio and other early wireless inventions. (Personally, I think the pictures are better on radio.)

As you may have noticed, National Semiconductor is not a major provider of digital VLSI chips that go into cell phones. So you might say that NSC isn’t a player in this wireless market, eh? No, you shouldn’t say that!

When the VLSI chips began to get specialized and optimized for high performance in cellular phones, the clock frequencies began to go up, and the logic feature sizes began to go down, as did the power-supply voltages—just like for microprocessors. And what falls out? A magic word! *Disintegration*.

When you make smaller features and run your VLSI chip on lower voltages, certain functions are hard to do. A decent audio amp can’t run efficiently on 1.8 V. Furthermore, a cell-phone amplifier has to reject certain kinds of nasty noise. So a good audio amp for a cell phone works a lot better on a separate chip at 3.3 V. Thus, this disintegration makes an external amp a good idea.

We have many good amps optimized for various cell-phone, portable, and wireless activities, such as the LM4880. (Why do people want stereo amplifiers in a cell phone? Why not use two cell phones, one for each ear? Don’t ask.) When your GSM phone has a lot of “bumblebee noise” at 217 Hz, an amplifier like the LM4890 can reject it nicely.

Switching regulators that can convert a wide range of battery voltages efficiently to the needed regulated voltages are never included on the VLSI chip. So we make lots of those regulators, such as the LM3200. Others are used to pump voltages up to go into LEDs and backlights for various displays. If you needed a

precision reference, you could integrate it on the main chip. But the yield loss makes this a loser. Do the math. It’s cheaper to add a separate chip. There are log-amplitude detectors for the RF power output like the LMV225. There are power-amplifier controllers, too.

Temp sensors for the voltage-controlled crystal oscillators and the output RF power transistors—and for battery recharging—usually do not go on the main chip. The LM20 draws very low power, and there are many other temp sensors optimized for portable use, with analog or digital outputs. After all, the main chip ain’t at the same temperature as

the crystal, which ain’t at the same temp as the battery. A single temp sensor isn’t right to do all those jobs. There’s a lot of places where cell-phone makers like to use linear chips, just like the digital computer makers do. They just don’t talk about it a lot.

So, is wireless really “everywhere?” Not at my house. **ED**

#### Comments invited!

rap@galaxy.nsc.com —or:  
 Mail Stop D2597A,  
 National Semiconductor  
 P.O. Box 58090, Santa Clara, CA  
 95052-8090

**BOB PEASE** obtained a BSEE from MIT in 1961 and is staff scientist at National Semiconductor Corp., Santa Clara, Calif.

\* George Gershwin, “They All Laughed,” 1937

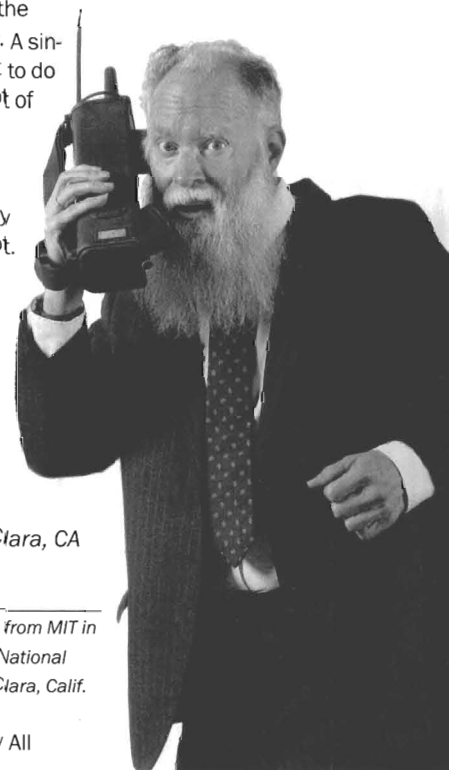





## PEASE PORRIDGE

BOB PEASE, *Contributing Editor*

• • • [rap@galaxy.nsc.com](mailto:rap@galaxy.nsc.com)

# BOB'S MAILBOX

**Hi Bob: I think this may interest you.** I repair electronics and had a guy bring me a TV/VCR. A month later he came back, and the belt I replaced was broken. It was one of those take-everything-apart-to-get-to-the-belt kinds. This time, the belt looked like it was 20 years old—nothing but little, hard chunks of rubber.

Yes, it was the same unit. He did not try to sneak in his friend's for repair. I started asking him what he could have in his house that could do this. It turned out it was the electronic air cleaner. Soon after that, a lady brought in a six-month-old VCR and the pinch roller looked 20 years old. "You have an electronic air cleaner," I told her. She looked a little shocked and asked, "How do you know?" After some thought she said, "Now I know why the rubber on my patio doors is gone."

Then there was another customer who turned white when I told him about air cleaners. He stated, "I have to replace all my windows at a cost of \$4000." He went on to tell me about how he had just replaced his carpet as the rubber backing had turned to dust.

• **Jonn van Laar** (via e-mail)

• **Pease:** Hi, John. Wow, I'm impressed. Good sleuthing. Thanks for the info. We're publishing your warning. Please tell me more about the "electronic air cleaners." Is this one of those types that emits negative ions? Please find out from your customers the name of the maker and the model number. How is it described? Note: when the rubber on the patio doors is replaced (and the rubber mat under the rug), there may be some synthetic material, such as neoprene, that will resist the ions a lot better than rubber. I'm not much of a chemist, but your customers might want to contact one!!

**Jonn van Laar responds:** Hi, Bob. I found the "Living Alpine Fresh Air Purifier Model 3500HL," also known as "Healthy Living HL-2," on eBay. It seems similar to the one that was allegedly causing the trouble. (Yes, that "electronic air cleaner" is the type that costs several hundred dollars, and it emits negative ions and "activated oxygen"—ozone. I guess that is the main problem!! /rap)

We had a guy selling them for as much as \$600. I remember smelling the air and it was just like what you got in the old days when you held a screwdriver close to the plate cap of the horizontal output tube on a TV. So my guess is that it is ozone. What got me was that it could do this to a belt inside a TV/VCR that is not open to the air—and in less than a month! (Hey, that activated oxygen really does get in everywhere! /rap) I do not know what kind of rubber it was. I am sure different kinds would react in different ways.

The unit uses some kind of RF signal because I remember looking on a scope. Just holding the probe close showed all kinds of



junk. I feel sorry for anybody that has one in their garage.

• **Pease:** Oh, man!!! Think of all the rubber hoses you'd have to replace!! Not to mention rubber tires and rubber toys!

**Dear Bob:** Mr. Ed Ganshirt wrote to you about a 120-A rating on a TO-220 packaged MOSFET (ELECTRONIC DESIGN, Aug. 18, p. 22). I think that this must have been a misprint (or misread) of what was meant to be 120 W.

• **Kent Nickerson** (via e-mail)

• **Pease:** You can go look up the datasheet, and it is very clearly amps, not watts. Go ahead and Google the IRF1407-ND! Besides, a TO-220 definitely can not handle 120 W, not even with an infinite heatsink!!

**HELP! PLL QUESTION** • I got an e-mail from a guy inquiring how to make a precise 59-Hz signal using a phase-locked loop (PLL), and my hateful computer ate the message before I could reply. Amigo, please resend your message, as I do know how to solve your problem. It's easy, using Application Note 210. /rap

**ED Online 11084**

**Comments invited!** [rap@galaxy.nsc.com](mailto:rap@galaxy.nsc.com) —or: Mail Stop D2597A, National Semiconductor P.O. Box 58090, Santa Clara, CA 95052-8090

**BOB PEASE** obtained a BSEE from MIT in 1961 and is Staff Scientist at National Semiconductor Corp., Santa Clara, Calif.



**Pease**PORRIDGE

**BOB PEASE**, *Contributing Editor*

• • • rap@galaxy.nsc.com

# WHAT'S ALL THIS MARKETING STUFF, ANYHOW?

**Okay, marketing is a dirty and nasty job**, but somebody has to do it. Sometimes I put on my “marketing hat” and try to do some of it myself. But the best insight into that is the quote I have paraded before a couple thousand attendees at my recent linear seminars: “The only valid market survey is... a signed

purchase order.” Well over 2000 people attended these seminars, and nobody knew who said that. Answer below. Hint: He was one of the Fairchild Eight. Your chances of guessing the right answer are about one in 10.

Marketing has several tasks, all involving judgement (i.e. guessing). The marketing manager has to come up with the answer to: “If we brought out THIS product, with THAT set of features, would it be popular?”

If you guess right, you get to try again. If you guess wrong, you get to try again—at a different company.

Here at NSC, many people have tried to guess what the market would favor. I have heard several contradictory stories of which products were recommended by whom. Nobody ever said it was simple.

When I was at Philbrick, we had lots of great and profitable products that were invented by engineers. I guess there were some marketing guys, but I don't recall who. But when we had a great new product idea, they got the heck out of the way, greased the slides, and let us bring it out. Bob Malter's P2 was a fantastic example. Nobody ever asked for it until it popped out full-fledged. My 4701 series comprised very popular V-to-F converters, and nobody ever asked for them.

When I was leaving Philbrick in 1976, I looked at several other companies. Some were run by engineers, and some were run by marketing people. The companies run by marketing people seemed to be proud of how they could imagine a new product that was great and force the engineers to make it. I could see where they had forced some amazing but overpriced (and not very attractive) products into the marketplace. But they had failed to bring out some naturally winning products. I recall that after I'd designed those V-to-F converters, the marketing guys at one company refused to believe there was any “market for VFCs.” But finally the sales guys and engineers convinced them that while there was no “market” for them, there were customers, so they finally got into that business.

When I joined National, it was the other way around. In those days, it was easy to invent a new product that people would like—and love. We didn't have to ask the permission of any marketing manager. We just had to put on our marketing hats. It wasn't really hard, and some of us got pretty good at it.

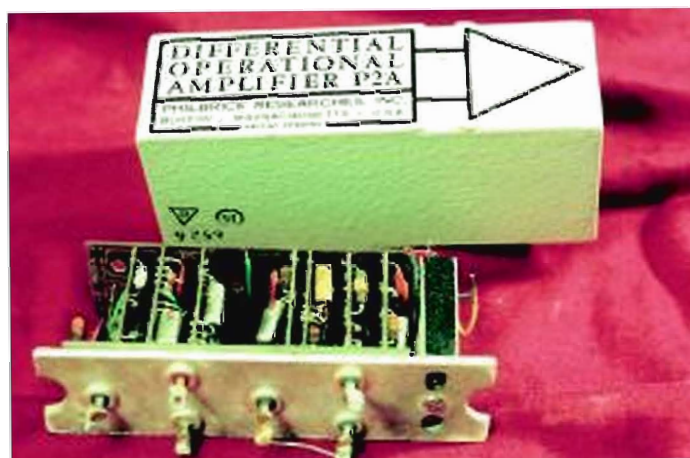

I mean, every new product I designed started with the concept of a datasheet for the new product. I would invent all sorts of features I wanted to make the datasheet look great. Then I would start my circuit design to try to meet all those specs and features. Occasionally, I had to redesign the datasheet, or the circuit, to get closer agreement. And all this time, I kept thinking about the features that would make me happy if I were a potential customer. Thinking like a customer is not too bad a way to design products.

So the guy who said that quotable saying was Jay Last, one of the Fairchild Eight and a very knowledgeable guy. In his context, it was largely true. His marketing guy could ask many customers, “Who would like to buy THIS integrated function, or a new silicon planar THAT?” Very few people would say “no.” But did they vote with their dollars when the product came out? Not so fast! **E D**

**ED Online 11138**

**Comments invited!** rap@galaxy.nsc.com —or:  
Mail Stop D2597A, National Semiconductor  
P.O. Box 58090, Santa Clara, CA 95052-8090

**BOB PEASE** obtained a BSEE from MIT in 1961 and is staff scientist at National Semiconductor Corp., Santa Clara, Calif.



## BOB'S MAILBOX

**Hi Bob:** I've been an avid fan of yours for many years, and I'm writing now to plumb the depths of your arcane knowledge. We've got a design that needs a little bit of insulation, and I told the engineer to use fish paper to do the job. She asked me a question that's got me stumped: "What's the origin of the term fish paper (and how did it come to be associated with vulcanized fiber)?" A search on the Internet left me still scratching my head. Any ideas?

■ **Matthew L. Severns** (via e-mail)

■ **Pease:** If you go to [www.jjorly.com/fish\\_paper\\_die\\_cut.htm](http://www.jjorly.com/fish_paper_die_cut.htm), it will explain about fish paper—why it has an electrical spec drawing and conforms to MIL-I-695F, and why it is rated to high temps with good electrical and mechanical characteristics. I gotta admit, it does not seem to explain the source of the name. On the other hand, [www.smallparts.com/products/descriptions/fshp.cfm](http://www.smallparts.com/products/descriptions/fshp.cfm) says that fish paper is made out of cotton rags. Maybe it's thus named because it smells like fish. Does anyone know the origin of the name?

**Dear Bob:** I want to raise a concern about the gaining popularity of using spread-spectrum techniques in switching power supplies (As in other digital computing chips... /rap) to allegedly reduce EMI. Of course, this does not really reduce the EMI. It just spreads it out so the equipment can pass the regulatory tests, which are performed using narrow-band detectors. Because a real receiver like a TV set is wideband, in practice, the interference is not reduced. (The total radiated power may actually be increased, as there is no need for shielding or good layouts. /rap)

One advertisement shows a CW interference carrier being reduced by what looks like an impressive 20 dB. But the reduction is only because the measurement is being made in a 100-Hz bandwidth. With the proliferation of wireless RF technology, I think we all need to design products that truly pass EMI requirements without resorting to tricks that exploit loopholes in the test methods. With the proliferation of switching power supplies and unfiltered lamp dimmers, AM radio has already become almost unusable.

■ **Mark Kolber** (via e-mail)

■ **Pease:** Well, every loophole will be investigated, and if they seem to work legally and save money, people will use them. Hey, shielding is expensive! And making a good new re-layout usually takes a lot of time—and it's hard to be sure that it will work! I don't see the FCC cracking down on this in the near future. Heck, people are permitted to spray broadband noise over our power lines (and they are not even twisted pairs)! Permissiveness seems much more rampant. Regulators don't give a damn. Anything that lets you get out a product faster and cheaper is a great idea, no?

**Dear Bob:** I am remiss not to write sooner—been terribly busy with hurricanes, grandkids, work, etc. I just got to your column on naps (ELECTRONIC DESIGN, May 12, p. 20) and I found it to be very funny, but quite accurate. Could it be that you and I are getting a bit long in the tooth? I am now 73—the days of working with Bob Widlar, Brent Welling, Brian Hollins, and Bob Swanson are a faint, but fond, memory. (I was with you at National Semi from 1976 to 1980.)

As I have told you, I still work full-time consulting for the USAF and plan to continue to do so as long as my health will allow. But on the subject of naps, I find that going home during the lunch break and taking a 15-minute "power" nap will refresh me entirely for the remainder of the afternoon. I have no trouble working a nine-hour day (with a 45-minute lunch period). So, I totally agree with you—naps are good things. And I really enjoyed your column.

■ **Jerry Robertson** (via e-mail)

■ **Pease:** Surprisingly, I usually get through the day without a nap during lunchtime. Not sure why. Keep up the good work!! Best

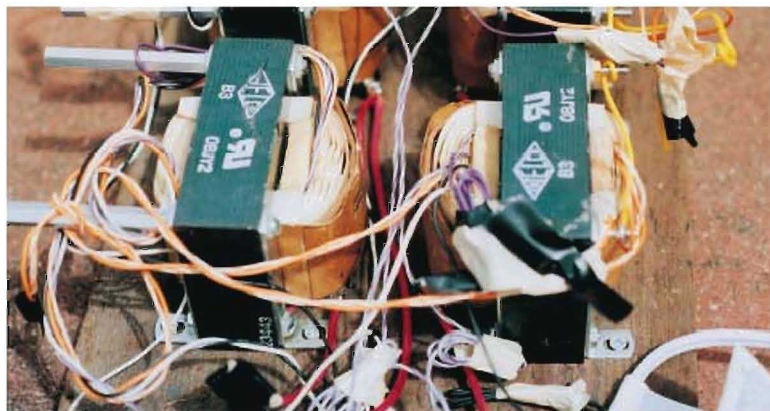

These transformers boosted my toaster from 1260 to 1460 W.



# WHAT'S ALL THIS LOGARITHMIC STUFF, ANYHOW? (PART 2)

The  $I_C$  versus  $V_{BE}$  of modern transistors has some excellent log characteristics, as we have discussed.\* If you ground a transistor's base and compensate for its  $V_{BE}$  with a matching  $V_{BE}$ , you can do some good logging over a wide range, from 1 mA to 1 pA, and really quite accurate from 100 pA to 100  $\mu$ A.

That's six decades where the limitation of  $R_{EE}'$  on the high end is the major limitation. Input leakage currents on the low end are not really a limitation, these days, as good CMOS amplifiers have  $I_{IN}$  smaller than 1/1000 of the 100-pA signal. Of course, this works best around room temperature. The compensating resistor  $R_x$  (1-k $\Omega$  wirewound resistor at +3500 ppm/ $^{\circ}$ C) works fairly well for a moderate temperature range, and it works best around room temperature. Figure 1 shows a standard log ratio circuit, found in AN-29 and in many books. Its output is -1 V per decade for inputs larger than 0.2  $\mu$ A.

However, there are definite limitations in speed of response. A large input current requires a large feedback capacitor, such as 500 pF, because the transistor adds so much gain to the loop that it ruins the loop stability. When  $I_{IN}$  is as large as 1 mA, the transistor has a gain of 800—too much gain to add to an op amp. (Op amps are happy with attenuation in the feedback loop, but they don't like gain added.) So we have to add a large  $C_F$ , such as 500 pF, to make the loop stable at high frequencies.

Now when  $I_{IN}$  is decreased down to 1  $\mu$ A, the loop is very stable and very slow. The 500 pF is much too big. The bandwidth falls below 1 kHz. A feedback capacitance of 2 pF would be plenty. Some of our customers needed a logger with good audio bandwidth over a wide range of input currents. What to do?

I remembered that some engineers back in the 1960s had this problem and used some diodes to solve it. But I never saw how they did it. So I went back to the scene of the crime. All I needed was a feedback capacitance that was big when the signal was big, and small when the signal was small.

I figured out that the circuit of Figure 2 might do it. All I had to do was build it up and try it out. Do a cut-and-fit on the capacitance sizes. Sure enough, it worked quite well. The effective feedback capacitance increases as the output goes more negative, and the diodes start to conduct. I used a fairly spacious layout, so the stray feedback capacitance ( $C_0$ ) was only 1 or 2 pF, due mostly to the amplifier's socket and the 1N914. If you made a really good layout, you could get the strays even lower than that and get fast response below 1/10  $\mu$ A.

I kept a bandwidth of 12 kHz, from 1/4  $\mu$ A up to 0.4 mA. I didn't really try hard to optimize it further. I stopped, as it was working entirely well enough for me. It did overshoot a bit, but it did not

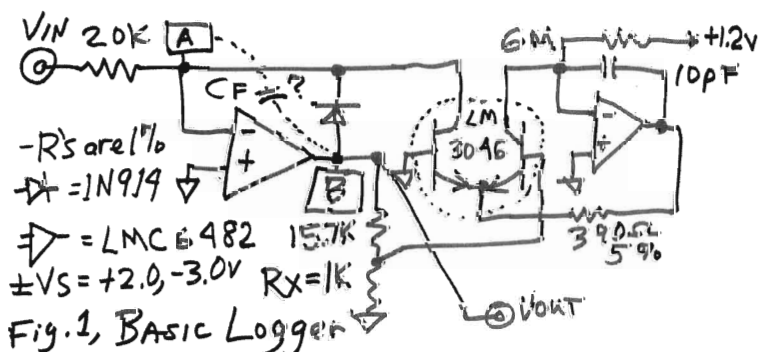

ring at any signal level. You have my permission to optimize it as needed. You might use three or four diode-R-C networks to cover a wider range or to get cleaner response at all levels. So there's an old trick that hasn't been seen for about 40 years, but when we have to reconstruct it, it works pretty well. **ED**

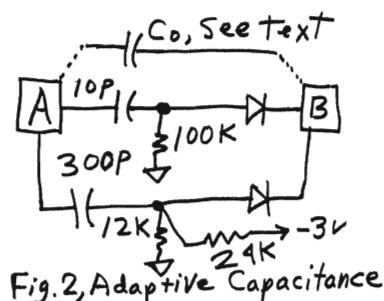

Comments invited! rap@galaxy.nsc.com —or: Mail Stop D2597A, National Semiconductor P.O. Box 58090, Santa Clara, CA 95052-8090

\* "What's All This Logarithmic Stuff, Anyhow?" *Electronic Design*, June 14, 1999, p. 111; ED Online 6068 at www.elecdesign.com

BOB PEASE obtained a BSEE from MIT in 1961 and is staff scientist at National Semiconductor Corp., Santa Clara, Calif.



## BOB'S MAILBOX

**Dear Bob:** I had to laugh at your recent column.\* I experienced similar product destruction with my (brand x) air cleaner. Let's see, I lost: all belts and wheels in two high-end (industrial) VCRs—and one a second time. Also, belts in three audio CD players, in a DVD player, three computer CD drives and one

DVD drive, plus a belt in a vacuum cleaner—three times.

*(Ouch!! That's painful!! /rap)* The air cleaner seems to be two appliances in one. It has an ozone generator and a positive ion generator. The positive ions don't destroy anything but make your walls and windows dirty by depositing dirt on them. If I were the litigious type, I'd smell class action.

- **John Spangler** (via e-mail)
- **Pease:** Well, I can't say I'm in your class action, but I am trying to help by warning everybody. Note that some companies, such as the Sharper Image, will sell you an air cleaner guaranteed free of ozone.

**Dear Bob:** I was the chief engineer of a Cleveland, Ohio, FM radio station back in the mid-1970s. Inside the transmitter building was the usual high level of ambient noise from the transmitter blowers. To hear program audio I had a fairly hefty receiver and speaker system. One day I noticed that there was something not quite right about the sound.

Pulling the front cover off revealed that the compliant rubber ring supporting the cone had completely disintegrated on both units. *(Uh, yeah. /rap)* I never actually smelled any ozone, but I'm certain some was being generated by the high potentials.

Judging from the September issue article, there must be some pretty elevated levels of ozone in those living spaces to cause the problems mentioned. Sounds like we should be more worried about ozone than radon gas!

- **John Mattesini** (via e-mail)
- **Pease:** Yeah, but a transmitter has a set of big fans to keep it reasonably cool. And the hot air is then sent out of the building, along with most of the ozone. So it's not as bad there as in some other places.

**Hi Bob:** I certainly do agree with your comments in "What's All This Wireless Stuff, Anyhow?" (ELECTRONIC DESIGN, Sept. 15, p. 22). Pictures are indeed better on the radio. A few years ago, Stan Freeberg, a once-notable comedian, made a series of commercials for radio, which were broadcast on (what else?) the radio. The purpose of the advertisements was to vividly illustrate the power of the human mind to visualize objects and tasks that would otherwise be impossible to portray on television or other visual media.

Imagine, as did Stan Freeberg, Lake Erie totally covered in whipped cream with giant battleships delivering maraschino

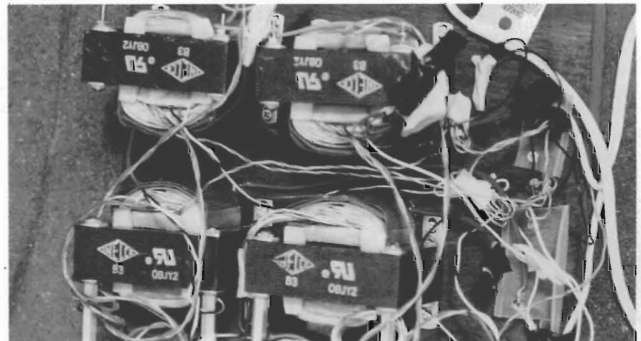

cherries! I can actually "see" that in my mind, can't you? *(Heck, I got it memorized! It's a classic. But wasn't it a bomber that dropped the cherry on top? I can still see that in my mind's eye. I don't recall seeing any battleships. /rap)*

The "eye of the mind" has always been more graphic and demonstrable than any graphic that can be presented. Remember all those radio programs that you and I listened to as kids? How did the "Green Hornet" look to you? How about the squeaking door on *The Inner Sanctum*?

- **Karl Kanalz** (via e-mail)
- **Pease:** Man, *Inner Sanctum* was too scary for me. It made me uncomfortable. These shows were a little too real!

**Dear Bob:** Your article on "Wireless Stuff" was most amusing. On a similar note, you might want to look at the wired world as well. In the 19th century, we had cable communications. And the system was totally digital. It was called the telegraph.

- **John A. Rupkalvis** (via e-mail)
- **Pease:** Gee, I don't even have digital cable communications at my house. I do have a telephone, but it's analog. 

**Comments invited!** rap@galaxy.nsc.com —or:  
Mail Stop D2597A, National Semiconductor  
P.O. Box 58090, Santa Clara, CA 95052-8090

\* ELECTRONIC DESIGN, Sept. 29, p. 18

**BOB PEASE** obtained a BSEE from MIT in 1961 and is Staff Scientist at National Semiconductor Corp., Santa Clara, Calif.



# WHAT'S ALL THIS AMT STUFF, ANYHOW? (PART 1)

The IRS recently "invited" me to fill out a form that puts fear in the hearts of strong men—Form 6251 for the Alternative Minimum Tax (AMT). I was "invited" to find out if this form would show any more tax liability. Hey, I paid my taxes back in August. I don't mind paying my taxes. I don't mind filling in my tax forms.

I have always done my taxes by hand without a computer or any professional preparer. (Actually, I never have any trouble filling in my tax forms. It's just collecting the numbers to plug in that's a lot of work.)

So I started trying to fill in this form. Unlike any other tax forms, it refers in a circular way to other tax forms and worksheets that have supposedly been completed in the past. Unfortunately, some of these alternative worksheets are hard to dig up, so I had to re-duplicate and re-invent them. The lines to fill in had a lot of circular thinking. I had to refer to various lines on worksheets for other lines. Often I was told to add zero to zero, then compare this to another number, possibly also zero. Then I had to multiply by 15%, 28%, or maybe 26%. It did seem to be a rotten and absurd form.

The AMT was originally designed in 1970 as a tool to harass tax-avoiders. Thirty-six years ago, some citizens and legislators were outraged to learn that 155 people with over \$200,000 dollars of income (which was a lot of money in 1969) were paying zero income tax. They did this by exercising various deductions and exemptions and tax loopholes. So the AMT's purpose was to make them pay something.

Now, 30 years later, outraged people are complaining that there are still over 600 millionaires who are paying nothing in taxes. They have an income of over \$1M but are still not paying income tax or even AMT. However, because it was not indexed against inflation, many more ordinary people and taxpayers are creeping up into the ~\$100,000 brackets where they (we) get nailed by the AMT.

Apparently you get into the AMT by having lots of deductions, such as state income taxes, mortgage interest, various kinds of incentive stock options, and exemptions for children. When Congress passed our tax codes, imperfect as they are, they wanted

to provide incentives for people with these expenses to have a tax break. But the AMT has no such incentives. It nails you on those items.

I had computed my AMT back in August and was satisfied that I owed \$000 of AMT—as in previous years. After all, I didn't have any exemptions for dependents or incentive stock options. So on Oct. 23, I started re-computing my AMT. I was quite surprised to find that I supposedly owed \$5414. I didn't like that answer, so I re-computed it. Maybe I had made some errors. In that buggy, corrupt AMT form, it would have been astonishing if I hadn't made an error. I cranked through it on clean sheets of paper and came up with \$17,300. I checked the first one and the second one, and I could not find any obvious errors. I started from scratch and came up with an answer of \$4222. I

compared this computation with the previous two, and I could now see where I'd probably made errors.

I decided to check it again, and it seemed to tell me \$3878. But I was nervous about that. I sent in the form for \$4222. If they tell me I made an error, and it's really \$3878 (plus penalty), I won't be surprised. I won't be surprised at anything.

If you have ever been surprised by an AMT tax bill, check 550 on the Reader Response card. If you think the Form 6251 is the worst form of all, and worse than all other tax forms put together, check 551.

Comments invited! rap@galaxy.nsc.com —or: Mail Stop D2597A, National Semiconductor P.O. Box 58090, Santa Clara, CA 95052-8090

BOB PEASE obtained a BSEE from MIT in 1961 and is staff scientist at National Semiconductor Corp., Santa Clara, Calif.



# WHAT'S ALL THIS AMT STUFF, ANYHOW? (PART 2)

As I said in my last column, I don't mind filling in my tax forms.\* I can usually look at the 1040 forms and figure what is happening. If I am normally in a 33% bracket, I can tell that the tax is really at a marginal (incremental) rate of 36.8%, or whatever. But in the AMT, I cannot decipher my marginal rate.

I may get the nerve to go in and increment my income by \$1000 and see what the real change is. But it would take me a couple of hours, and I'd have to be sure I was not making any mistakes in the first place. I'm guessing it's up near 38.9%, due to discontinuance of various exemptions.

The big trouble with the AMT is that it brings in so much money! Many congressmen have expressed their unhappiness with the AMT, but they recognize that if they want to reform it, they will have to find some other source of funding for the government. And, (R) or (D), nobody has a good idea how to do that.

I think I know what I'll do next year. I'll get my taxes all done in July, the best I can do it. Then, I'll turn in an advance copy to a good honest tax preparer and get his opinion if I have done everything right. If I've done anything wrong, I'll leave time to recompute and recopy them before August 15. I wouldn't trust the preparer to do them for me, but I'll look at what he has to say.

Is there any way to plan ahead and avoid paying AMT? Not very easily. There are discretionary expenses you can take in different times to minimize your conventional 1040 taxes. But that doesn't work well for AMT.

One thing you can do is avoid exercising a big stock option and getting hurt if the stock goes way down. I wouldn't mind exercising a stock option and having to pay taxes on my gains. But if I exercise and the stock goes down, I will have to pay AMT on the stock gain, even if there was a loss making the stock basically worthless. If I take an option, I always sell some of it, to make sure I don't take a beating, paying taxes on something that's worthless. Usually I prefer to sell old stock, of the same type, so I only have to



pay taxes on long-term capital gains. At first when I started studying the AMT, I thought I would get screwed out of the 15% rate for long-term capital gains, but apparently not.

So when will Congress do something about this AMT injustice? When enough people complain. Every year, more and more people are caught up in this net, and when enough complain, maybe we'll get some action. And if I sell this column 10 times over, maybe it will pay for my AMT bill. No, not really.

## BOB'S MAILBOX

**Hi Bob:** ...I would like to know how you normally do the following: In some high-frequency circuits, for instance in resonant dc-dc converters operating in the range of a few megahertz, it is necessary to look at current and voltage waveforms simultaneously. How do you ensure that the current

and voltage waveforms have the same time delays so they can be compared?

- **Javier Chivite** (via e-mail)
- **Pease:** I don't use a current probe very much, but I guess you just put in a calibration test. For example, if you have a nice crisp voltage, put that on one probe, add a 1-kΩ resistor to ground, and let the current probe see that current. If there is any delay, such as a few nanoseconds, you can easily see it and subtract it from ongoing measurements. Write a note on the current probe to help you remember it. **ED**

Comments invited! rap@galaxy.nsc.com —or: Mail Stop D2597A, National Semiconductor P.O. Box 58090, Santa Clara, CA 95052-8090

\*ELECTRONIC DESIGN, Dec. 1, p. 20

BOB PEASE obtained a BSEE from MIT in 1961 and is staff scientist at National Semiconductor Corp., Santa Clara, Calif.



# What's All This Future Stuff, Anyhow?

I was down at an "Arrowfest" in Plano, Texas, a few months ago. We had a little panel session about the future with Bill Klein of Texas Instruments, Arnold Williams from Analog Devices, and myself. Most of the audience agreed with the three

of us (and the moderator)—the future will have a lot of analog.

When we see that the power-supply drain of a fast processor at 0.09  $\mu\text{m}$  is largely related to the device leakages—which aren't very predictable and can't be modeled easily—hey, that processor is relying on analog characteristics.

Remember the old days, when engineers were struggling to bias up germanium transistors so their bias wouldn't suffer from thermal runaway? Now, the silicon circuits are on the verge of thermal runaway.

It will take some good, tough engineering to solve the layout and heating problems. Maybe when they turn off the clocks to some subsystems, that area of the chip will stop self-heating, the temperature will go down, and the leakage will decrease—a kind of thermal un-runaway.

I wonder what Moore's Law has to say about that. Obviously, when the "process" goes down to 0.065  $\mu\text{m}$ , it will get much worse. Now that designers can't keep shrinking things, the digital field is going to look a lot different. What will they sell us next year? Microprocessors that aren't just fast battery dischargers?

**FUTURE POWER** • People are still bringing up the old saying that "Fuel cells are the power source of the future—and always will be." Down here in Silicon Valley, the Transit Authority operates a couple of busses running on fuel cells. This is an ideal area, because it's so flat with very few hills. (They'd never cut it in San Francisco.) From what I hear, the fuel cells have a very finite life and will need to be replaced every few months. And they're expensive! I'm waiting to hear how those busses work out.

Engineers, scientists, and chemists have been trying for many years to reduce the price of fuel cells by an order of magnitude or two. Great! NASA is very happy to pay for such exotic energy sources. Now the fuel-cell makers only have to improve the cells by three or four more orders of magnitude before they fit into future cars.

Are high-efficiency solar panels headed for a big future? I've seen studies that say inexpensive (not-so-high-efficiency) solar arrays are the right way to make cost-effective energy. It's fine by me, if the cost of a watt keeps going down. Mr. Ovshinsky of Energy Conversion Devices (ECD) has been saying that for years, and people are starting to follow him.

Furthermore, people are beginning to see that nuclear power plants have a future. It's better than pretending we can buy cheap oil forever. Besides, nuclear power has a much more reliable availability factor than solar power or wind power.

All we have to do is get the politicians to agree to hide the nuclear spoils where they won't contaminate us and poison us all.

And maybe this time, we can make sure the shale-oil conversion experts get going and keep going. The U.S. has enough oil-shale to last us many decades into the future for a large fraction of our energy needs. We only have to prove that we can rely on it at some plausible, reasonable price—and not chop the support for that energy when the oil shock decreases.

So while I'm not very good at predicting the future, lots of other people are predicting good things! I just hope I'll be hanging around for many more years to smile at them when they get here! Nuclear-powered op amps, anyone? ☺

**ED ONLINE 11688**

Comments invited! rap@galaxy.nsc.com —or:  
Mail Stop D2597A, National Semiconductor  
P.O. Box 58090, Santa Clara, CA 95052-8090

BOB PEASE obtained a BSEE from MIT in 1961 and is Staff Scientist at National Semiconductor Corp., Santa Clara, California

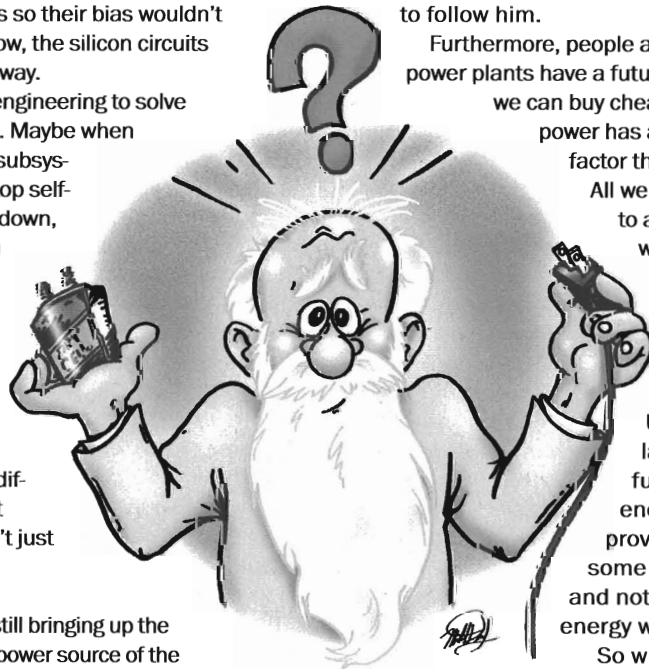





## PeasePORRIDGE

**BOB PEASE**, *Contributing Editor*

• • • rap@galaxy.nsc.com

### Bob's Mailbox

**H** **I Bob:** Back in the early '70s, I was an EE major at Lowell Tech in Lowell, Mass. Within easy walking distance of the dorms, there was an electronics surplus store in one of the old textile mill buildings. One day I found some Philbrick P65AU op-amp modules there.

I bought several of them, for maybe \$5.00 total. (A bargain. /rap) I decided to build a stereo hi-fi amp around them. It took the better part of the semester to build it, and I nearly flunked out as a result. But I ended up with a pretty good stereo amp at the end. I learned a lot by building the amp, a lot more than they were teaching me in class at the time!

Limited by the 30-V supply the op amp would run at, it didn't put out a lot of power. But with some efficient bass-reflex speakers, it was loud enough. (Check. The P66s were useful? If you had enough of them, you could parallel several of them or add other boost transistors. /rap)

A few years later I took the amp to a Tech HIFI audio clinic, where they got a good chuckle when they saw my homemade amp. But when they ran the frequency-response and distortion checks, they were quite impressed.

(The P65 wasn't very fast for slew rate. It had about 0.6 V/ $\mu$ s, so at 20 kHz, it could barely swing 8 V p-p. But most program material doesn't have a large amount of content at 20 kHz. The P65 also was a good low-noise preamp for phono cartridges, etc. /rap)

I used that stereo amp for many years and eventually gave it to a friend of mine, who might still be using it. I still have a "spare" P65AU module and a P66A booster follower, which I never did find a use for.

- **Steven Weber** (via e-mail)
- **Pease:** Take good care of them, Steven! We may need them someday! I've recently been running some P65s in a 1-ms delay line, using 10 H of inductance.

**Hi Bob:** My son is a chemist, so I sent him an e-mail asking him about the ozone reaction on rubber and rubber products (ELECTRONIC DESIGN, Sept. 29, p. 18.). Here is his reply:

"Ozone is a highly reactive form of oxygen, which is why it can be dangerous to human health as well. Ozone is one of the primary causes of the degradation of rubber because it reacts with any unsaturated double bonds left in the rubber polymer. It can also react with regular covalent-type polymer bonds, but this is more of a minor reaction. Once the reaction has started, it basically goes down the polymer chain via free-radicals and 'unzips' the polymer molecule—effectively destroying it. Tire manufacturers minimize the effect of ozone degradation by adding antioxidants to their tire formulas and waxes that protect by blooming to the surface of the tire and forming a coating, effectively sealing the surface molecules of the rubber from the air and ozone. This is why the tire manufacturers discourage the use of products like Armor All on the sidewalls of

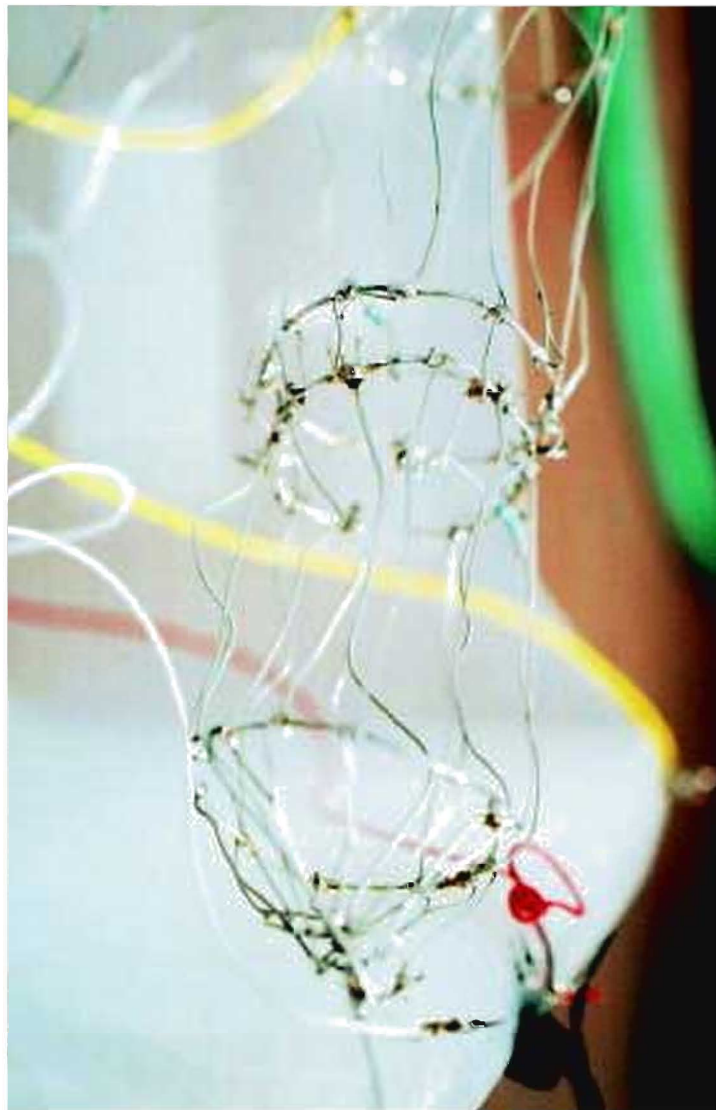

the tires because the Armor All can solubilize the waxes and then remove them over time."

- **Dave Miller** (via e-mail)
- **Pease:** Hello, Dave. Well, that certainly seems to be the right story on ozone. If it beats up rubber, imagine what it does to our covalent bonds! That's what they were complaining about when Los Angeles was so smoggy! It's interesting how tire makers protect their tires. Too bad rubber belt makers can't do that. Or our lungs!

**Dear RAP:** Since you were quoting only the lyrics from "They All Laughed" (ELECTRONIC DESIGN, Sept. 15, p. 22.), and not the music, perhaps the credit should have gone to Ira Gershwin, instead of George. George just did the music...

- **Bruce Walker** (via e-mail)
- **Pease:** Hello, Bruce. Well, you are quite right. I must have goofed. My big reference book, American Popular Song by David Ewen, did say exactly that. I'm sorry! ☺

**ED ONLINE 11865**

Comments invited. rap@galaxy.nsc.com —or:  
Mail Stop D2597A, National Semiconductor  
P.O. Box 58090, Santa Clara, CA 95052-8090

**BOB PEASE:** obtained a BSEE from MIT in 1961 and is Staff Scientist at National Semiconductor Corp., Santa Clara, Calif.



**Pease**PORRIDGE

**BOB PEASE**, *Contributing Editor*

• • • rap@galaxy.nsc.com



# What's All This Crampon Stuff, Anyhow?

**B**ack in February 1955, when I was just 14, I snowshoed with Professor John A. Williams, “Alpine Fred” Torrey, and a group of Explorer Scouts up to Crag Cabin at the 4200-ft level on Mt. Adams in New Hampshire.

I was strong enough to carry a little extra weight, so they volunteered me to carry some crampons—a set of spikes for climbing on ice and hard-packed snow. I carried them, though I had no idea what they were good for.

After we ascended up to 4400 ft, we started onto some ice and frozen snow slabs. Wearing the crampons, I immediately realized that I was master of the snowscape. After I helped escort my friends over the icy spots, I had the best fun hiking. I could amble easily across these slanted drifts, at any angle, without worrying about the rough rocks or lumpy shrubs under the snow. It made ascending the 5798-ft mountain easy and fun.

The next February, I decided to lead my own trek up there. I was just 15, and a good camper and hiker, and I knew how to do all the things we had done a year earlier. So we planned carefully and got all the necessary clothes and equipment. It never got below -20°F, and we had a great hike. All the hikers had crampons this time, and we strode easily across the frozen snow, farther than ever. In later years, we went back for more of such climbing, and it was wonderful.

Now, 50 years later, we're going to climb up there again for a 50th anniversary trek. But one of my friends has very large boots, and it's hard to find crampons to fit them. What to do?

In November, I was trekking up in the Annapurna region of Nepal. (See my trip report at [www.national.com/rap](http://www.national.com/rap).) I had brought

along some ice creepers, in case we were waylaid by a lot of ice or snow. I tried some tests up above 14,000 ft at Annapurna Base Camp and walked across some frozen snow. The four-corner stamped-steel ice creepers worked, with traction just a little better than good climbing boots (when they didn't fall off).

Likewise, I evaluated some Yaktrax, and they also provided good traction. “If I were crossing an icy parking lot, they would work just a little better than a few handfuls of salt or sand,” as I explained to my buddies.

“But there are no parking lots up here,” they replied.

“Sure, this hard-packed snow and ice over here is just like a stomped-down parking lot!” I said. I motioned to a strapping young Nepali porter, and he put the creepers on. We started a friendly pushing contest. Both types had surprisingly good traction. There was no serious advantage. So I found that the Yaktrax are suitable for icy or slippery, snowy parking lots. The four-corner steel cleats weren't quite as good, but they would save you from falls on a flat area of slippery snow or ice.

Later I went shopping in Kathmandu and visited the used-equipment markets. I found several kinds of excellent new crampons, but at good, high prices. I mean, \$120 to \$180 is a fair price if you're going to do technical ice climbing, but I wouldn't pay that much. Finally I found the secondhand ones shown in the photo, adjustable up to 14 in., with excellent welding, for just \$21. So we are all set for our New Hampshire trek.

Would I bring the Yaktrax as backup for our good crampons? Nah. But I will bring some baling wire for any needed repairs. The main problem with crampons (assuming they don't break) is that you can easily slash the legs of your pants—or your legs—with the sharp spikes. We plan to hike slowly and carefully and use lots of rubber bands to keep the legs of our pants from flapping. ☺

ED ONLINE 11919

**Comments Invited!** rap@galaxy.nsc.com —or:  
Mail Stop D2597A, National Semiconductor  
P.O. Box 58090, Santa Clara, CA 95052-8090



**BOB PEASE** obtained a BSEE from MIT in 1961 and is staff scientist at National Semiconductor Corp., Santa Clara, Calif.



## Bob's Mailbox

**D**ear Bob: I have a little microcontroller circuit powered from a 115-V ac to 24-V dc supply that is then further stepped down to 5 V with a buck converter. An RS-232 converter, whose switched capacitors give  $\pm 8$ -V swing, is used to communicate to a PC. The problem I have is that connecting to a grounded PC has blown out the serial port on the PC. We grounded the common in the circuit and have had no problems since.

I'm looking to understand what possibly could have happened. Could the 24-V supply have floated up and accumulated enough charge to blow out the port? If so, how does this happen? I have also seen in many circuits a 1-M $\Omega$  or larger resistor and a 0.01- $\mu$ F capacitor in parallel tied between the power-supply common and earth ground. Is there some standard or something else I missed that suggests this? Can you please enlighten me or point me to a reference? Thanks.

- **Jeff Slefke** (via e-mail)
- **Pease:** I am not an expert on this, but I can make a guess.  
(A) The ground of the RS-232's supply must have floated up to a high voltage, perhaps more than 100 V. There probably was something like a 0.01- $\mu$ F capacitor, as you suggested.  
(B) When the pins of the connector were connected to the serial port, the ground pin (or pins) did not connect first. (If it had, it would have resulted in no harm.)  
(C) In a well-designed system, the ground pin (or pins) would be longer than the signal pins, so it couldn't help but connect first. If the signal pin connected first, that might cause some harm. And it did.  
(D) A well-designed serial port ought to have 1 k $\Omega$  in series with the inputs, going over to some protect diodes. But these days, everybody leaves protection components out of their computers because "it's too expensive" or because "extra components hurt reliability." That sounds like enough to explain it.

**Hi Bob:** I was teaching a unit on transistor amplifiers yesterday, and a student asked me why transistors are labeled as Q1, Q2, Q3... in schematic diagrams. So as an old timer with a wealth of trivia, why the letter Q for transistors? Love your *Electronic Design* column.

- **Michael Halbern** (via e-mail)
- **Pease:** When vacuum-tube circuits were developed, all the other letters were used to identify Transformers, (Vacuum) Tubes, Diodes, Rs, Cs, Ls—and Q was left over for "miscellaneous." When transistors came along, they were about as miscellaneous as you could get, so they became Qs.

**Hello Bob:** Last night I was replacing the CR2032 battery in an inexpensive digital tire-pressure gauge, when the small liquid-crystal display fell out. On closer inspection, I found it had no wires or electrical contacts whatsoever. I was able to sandwich

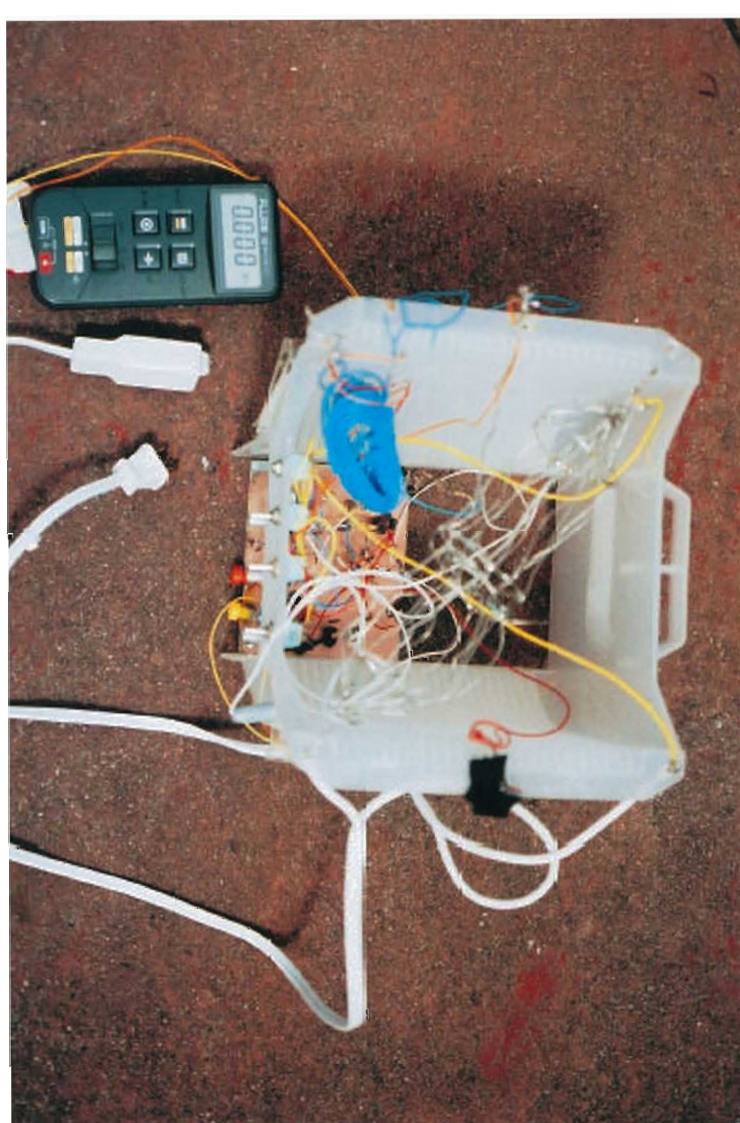

the LCD and two associated foam pieces back between the PC board and the housing, and it worked. How do they do that?

- **Steve Goss** (via e-mail)
- **Pease:** The foam is made of alternate vertical stripes of conductive and insulating foam. Both are kinda squishy. The pitch of these is like 10 times smaller than the pitch of the electrodes on the PC board and the LCD. And I bet you can see these, presuming you look real close.

**Dear Bob:** Read with interest your experiences and recommendations on napping (*ELECTRONIC DESIGN*, May 12, 2005, p. 20). When I am caught by my boss with head on desk later this afternoon, I shall be sure to have on hand your invaluable guide to use in self-defense.

- **Howard Jones** (via e-mail)
- **Pease:** No, all you have to do is lift up your head, lift up your eyes, lower your eyes, and say, "Amen." Then stand up and ask your boss what you can do for him. Of course, this doesn't work very well if you're snoring! ☹

**Comments invited!** rap@galaxy.nsc.com —or:  
Mail Stop D2597A, National Semiconductor  
P.O. Box 58090, Santa Clara, CA 95052-8090

**BOB PEASE** obtained a BSEE from MIT in 1961 and is Staff Scientist at National Semiconductor Corp., Santa Clara, California.



# What's All This Autosave Stuff, Anyhow?

**W**hen I first began to type on a computerized word-processing system, I realized that a power outage was potentially disastrous. You could type a carefully crafted four-page memo, nicely polished, and

it all would go away if the power went out—even for a second, or if somebody kicked the cord a little too hard.

When I used the Coleco Adam, the process of saving was quite a big deal. Copying onto Adam's audiotape took well over two minutes, and you could prepare and drink a cup of coffee while waiting. Worse yet, if you saved the text too often, you could fill up one tape with 14 saves. Each document "save" was saved separately and didn't write over the previous save. This was okay, better than no save at all, but not great.

Lately, I have been getting fewer and fewer power outages. A laptop with its own battery power is substantially immune from power loss, too. But I can still lose my story if the computer locks up. Just last week, I typed for an hour, and the computer locked up and refused to let me save or copy anything. Thanks, Bill. Time to retype from memory.

In between, I was using PC Write Lite from Quicksoft (no longer in business, alas). One of its nice features was its autosave. I could just set the autosave for "10 minutes min or 2000 bytes min." After that amount of typing, it would stop briefly and save what I had typed. I consider that to be one of the finest features of a civilized computer.

When my wife got a Mac, I asked her how her autosave worked. Her reply was, "the what?" I looked in her computer manuals, and I was horrified to learn that there was none. I looked in the big, comprehensive book on OS-X by Robin Williams. The best advice she has is "SOS," that is, "Save Often, Sweetie." Thanks a lot, Robin.

There are too many ways for computers to goof up, destroy your carefully typed messages, and leave you in the lurch. I'm not a connoisseur of error messages, but I've been shafted in about 80 different ways that lock up the computer or destroy a message. Sometimes there isn't even any error message. It's just all

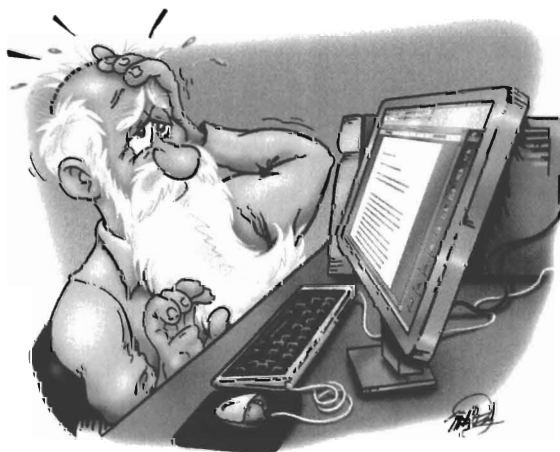

locked up. So maybe I should get a cheap little timer, set it for 10 minutes, and save every so often. For sure, five minutes of lost typing is a lot better than 50.

Somebody told me that Microsoft Word has an autosave. You can set it for every so many minutes, but not for the number of bytes. I guess that would be better than nothing, but a fast typist still could get in trouble.

Recently, I had a couple of e-mails arrive about three days late. One of them was blamed on a balky firewall, which has

probably been fixed. The other was blamed on some balky aspects of Mozilla 1.0. Maybe the newer 1.5 version will fix that. Usually, only spam is delayed. But this time I noticed that a colleague had sent an e-mail that arrived three days late. I sure noticed that discrepancy.

I've had other problems recently, too. A couple of e-mails arrived and then disappeared. A boffin is trying to reconstruct them from backup files, but they aren't showing up yet. I guess the main point is that computers hate me, and I despise them—that is, digital computers. I get along fine with analog computers.

When I try to send myself a copy of an e-mail, the autocomplete guesses that when I type "rap," I'm trying to send it to my colleague Anne Rapp. I keep erasing her name from my address book, and it keeps popping up again. At least this one can't be blamed on Bill Gates.

P.S.: Yes, I have been saving this draft. ☺

**Comments invited!** rap@galaxy.nsc.com —or: Mail Stop D2597A, National Semiconductor P.O. Box 58090, Santa Clara, CA 95052-8090

**BOB PEASE** obtained a BSEE from MIT in 1961 and is staff scientist at National Semiconductor Corp., Santa Clara, Calif.



## Bob's Mailbox

**D**ear Bob: The letter from Dave Miller\* reminded me of a recent tire episode and questions. The front tires of my Camry needed replacing. The dealer insisted that the new pair go on the rear (and rotated the rear tires to the front). He claimed that was now the recommendation of the tire manufacturers. I recall that new tires used to be put in the front. When did this change, and why?

*(What about the recommendation of the car manufacturer? Does its owner's manual give any advice? As far as I'm concerned, recommendations of tire manufacturers are about as valuable (and trustworthy) as you-know-what on a boar hog. When people get stupid, I have to be very skeptical of that advice. Of course, on a rear-wheel drive car, you may want better traction from new tires on the rear. Likewise, on a Camry, you may want better traction from new tires on the front. /rap)*

Also, they left a sticker on explaining that the tires were inflated with nitrogen. What's wrong with air, as available at most gas stations?

- **Mike Smolin** (via e-mail)
- **Pease:** Technically, the oxygen in air can oxidize the rubber a little. So I suppose the dealer is trying to impress a bunch of yuppies. Or, the dealer is admitting its lousy tires are liable to be oxidized... But I guess if we soon will be able to refuel our cars at a hydrogen station, we can fill up our tires at a nitrogen station. What a bunch of crapola. (That's a technical term...)

**Dear Bob:** Just a quick note to make you aware of my Web site devoted to analog electronics and history. Check out [www.kennethkuhn.com/hpmuseum](http://www.kennethkuhn.com/hpmuseum). Take the picture tour of my shop and museum. This may be one of the largest home electronics shops anywhere. All of this vintage analog electronics is menu driven using an analog GUI—the instruments perform the function the knobs point to. No programming required. Help menus not needed. (That, I like!! /rap) I enjoy your column in *Electronic Design*. Keep up the good work.



**These vintage HP oscillators, meters, and related devices represent just a fraction of Ken Kuhn's collection of electronic equipment.**

- **Ken Kuhn** (via e-mail)
- **Pease:** Hello Ken. That's a very nice museum! At first I was worried about those tall racks of equipment—just an invi-

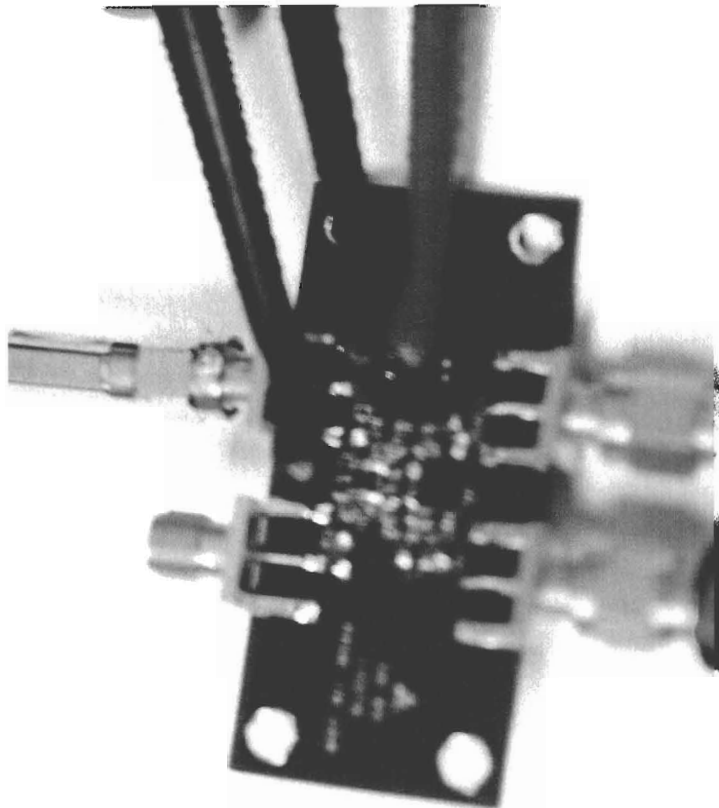

*tation for an earthquake to knock them all down (see the figure). But as you appear to live in Alabama, I guess they are safe. I hope you aren't too close to that earthquake site near New Madrid, Illinois, or Missouri, or whatever. I guess you're at least 100 miles away, allowing for the size of Mississippi.*

*Do you have a "Wanted List" of old HP instruments or instruction manuals? I too used to study the schematics of the new instruments such as TEK, HP, Data Precision, etc. These days, everything is so computerized, and most of it I hate. Menus, I hate. I prefer your analog GUI. It's like Analog PowerPoint. There also is a Philbrick Archive people should check out. Take a look at [www.philbrickarchive.org](http://www.philbrickarchive.org).*

**FINDING PAST COLUMNS** • People often ask me how they can find a recent column on a particular subject. It's easy to find most of the most recent 200 columns and Mailboxes going back over nine years, and a few dozen before that. Go to my Web site at [www.national.com/rap](http://www.national.com/rap). While you're there, take a peek at some of the horrible pictures. There are also links to various vacuum-tube op amps, other old columns (such as *Widlar Stuff*), and my *Lists*.

Next, click on the "ED Columns" and then on "click here." A fairly good little search engine will appear. But if you're interested in my stuff on "doctoring," don't just search on "doctoring," but on "doctoring stuff." If you're interested in searching for recent "Ozone" topics, that turns up nicely, even if there wasn't any column about ozone. It searches the readers' letters, too. /rap

\**ELECTRONIC DESIGN*, Jan. 19, p. 18

**Comments invited!** [rap@galaxy.nsc.com](mailto:rap@galaxy.nsc.com) —or: Mail Stop D2597A, National Semiconductor P.O. Box 58090, Santa Clara, CA 95052-8090

**BOB PEASE** obtained a BSEE from MIT in 1961 and is Staff Scientist at National Semiconductor Corp., Santa Clara, California.



# What's All This Mental Math Stuff, Anyhow?

**S**ome night when you can't get to sleep, try these puzzles in your head in the dark. They're at least as good as counting sheep. I've done them in my head, and they're kinda fun.

**1** Little Egbert bought a mountain. Its shape was a perfect hemisphere with a 5270-ft radius, set on a flat plain. He decided to build a railroad to transport him to the top. It was a monorail, which made it very easy to plan, with minimum width, and only one rail. The rail was offset 10 ft away from the surface of the mountain, to avoid digging, so the radius was exactly 5280 ft. The train could only ascend a 4% grade. The basestation was at the very bottom of the mountain, so the train could not get a running start up the hill. How much track did Little Egbert have to buy? (a) 25.00 miles (b) 25.020 (c) 25.040 (d) 25.40

**1b** For extra credit, if the train leaves the basestation going north on the west side of the mountain, from which direction does it approach the summit? I don't have a really solid answer for this one. You tell me!

**2** Little Egbert was walking across a field at 2.000 mph. The closest road ran true north, but the place he was going was 2 miles north and 0.1 miles east of his starting point. So he walked straight across the field, the shortest route between two points. His brother Pythagoras decided to walk along the road at 2.000 mph, for 2 miles, and then cut true east. When he got to the corner and started east, he saw that Egbert was quite close to the end point. He decided to speed up to get there at the same time. How fast did he have to walk to achieve that? (a) 8.0 mph (b) 16 (c) 80 (d) 160.1 (e) 442

**3** It's easy to set up two double-pole double-throw switches, one at each end of a room, so people entering the room can turn a common lamp on or off with either switch. Little Egbert added a new kitchen and dining room to his house. The kitchen was triangular with three doors. How could he arrange three switches so that anybody entering at any door could turn the main lights on and off just by throwing the adjacent switch? The dining room had four doors. How could he arrange switches at all four dining-room doors with the same capability? (Note, I just got a new kitchen with three doors and a new dining room with four doors.)

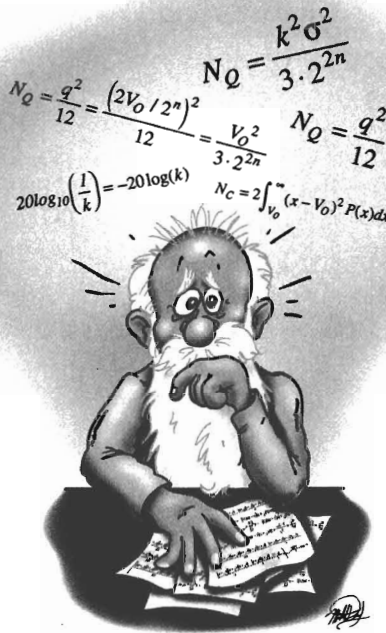

**4** Here's another sphere problem. Little Egbert sat atop a 16-ft stepladder, in Quito, Ecuador, astride the equator. He lowered a weight by a thread from a well-defined point at the top of the ladder to mark the place on the ground directly below it. Then he pulled up the weight—and waited—and dropped it. It hit the ground at a place not exactly the same as the first point. What was the difference in position? This goes to show that when you drop something, it does not just fall "down." (Unless you are at the North Pole or the South Pole.) Assume the radius of the Earth is 4000.000 miles and that  $g = 32.0 \text{ ft/s}^2$ . Thus, the rotational velocity of the Earth is 25,132.74 miles/24 hours, or 1047.20 mph, or 1535.89 ft/s, or 18430.70 in./s. An accuracy of 1% is requested. (If you have a release mechanism that does not affect the weight's transverse motion, you can find out how far you are from the equator.

Or, you could find out if you have a release mechanism that does not affect the weight's transverse motion by rotating the release mechanism in various directions.) (a) 1.4 mils (b) 14 (c) 34.2 (d) 112

**5** Compute the square root of 156 to a precision better than 1 ppm. (It is easy to compute to 1 ppb.)

The answers will be published in *Electronic Design*. Complete solutions with explanations will be posted on my Web site at [www.national.com/rap](http://www.national.com/rap) on April 15. (I apologize in advance for any complaints that I should have written this in metric terms. Sorry, but that's not going to happen. Brain puzzlers do not start out "There was a hemispherical mountain with a radius of 1609.265 m...")

**Comments invited!** rap@galaxy.nsc.com —or: Mail Stop D2597A, National Semiconductor P.O. Box 58090, Santa Clara, CA 95052-8090

**BOB PEASE** obtained a BSEE from MIT in 1961 and is staff scientist at National Semiconductor Corp., Santa Clara, Calif.



# What's All This Bivouac Stuff, Anyhow?

**O**kay, my old friends Mal and Jon and I were planning to hike up a big hill, Mt. Adams, near Gorham, N.H., in early February. On snowshoes. We'd have 3000 ft of snow to ascend, and it gets steep.

We considered the potential terrain, like a lot of packed snow on the ground, which would be fine. But would there be a lot of new snow? A foot of new snow would really slow us down. Two feet of new snow would cause some serious problems, because in a group of three, each person has to do an average of one-third of the work breaking trail. Even if you have never hiked in deep snow on snowshoes, you would figure out pretty quickly that breaking trail is a lot of work. We all figured this out fast in 1955, when we started up this same hill.

Even a half-foot of snow is a good, hard test for a group of six or 10 people, as the relevant fraction is still challenging. With only three of us—as well as the possibility (probability) of one or two feet of new snow—what would we do? Give up and go home? Heck, no!

I figured out fast, as I contemplated this problem, that we would have to be prepared to bivouac up on the trail if there were bad conditions. We would have to set up a minimal shelter, lay out our sleeping bags, sack out for the night, and restart the next morning. We certainly wouldn't want to go back down to our car and restart from down there. That would be too slow. But I've heard of people who have had to do that, as they had no better plan.

**GIMMIE SHELTER** • So, what's the shelter? A big square of plastic, about 8 feet square per person, would keep us from getting too damp or snowy. Wearing our snowshoes, we'd have to stomp down a shallow, broad hollow into the snow, even if the hillside had a steep slant. Next, we'd have to put the plastic sheet over our packframes and under our foam pads and then lay out our sleeping bags on top of that. And, we would have to pull the rest of the plastic sheet over us—and hunker down for a dozen hours. It's not exactly the same as sleeping, but some sleep may be possible.

Also, we would have to plan some sustenance. I've invented some light and quickly heated food—a dehydrated soup with pre-



cooked sausage and crackers for supper. On the trail, I would have to fire up our stove and heat some water. Then, after some coffee and/or hot chocolate plus a couple of breakfast bars for the morning, it would be back into the snowshoes and up and at 'em.

What if the only good bivouac spot is well below where we want to stop? We would set up our camp and take a break. Then we would walk up farther and keep breaking trail for a while until we almost got tired, or until it got kinda dark, and then go back and sack out. It's very important to keep from getting too tired.

After we got to our camp, Crag Cabin, at 4200 ft, we would have no great

amount of trouble with snow. Up above the timberline, the fluffy snow blows away, mostly. We would just put on our crampons and walk, per my recent column on that subject (*ELECTRONIC DESIGN*, Feb. 2, p. 20, *ED Online 11919* at [www.electronicdesign.com](http://www.electronicdesign.com)). The descent would be trivial. Even if we got one or two or three feet of powder, it would barely slow us down.

So while I have rarely done much bivouacking, I sure know what to do. All we needed were some good plans and that 7-oz square of plastic.

How did this work out? We had very little snow, and that was hard-packed. So we left our tarps in the car and had no trouble. We never even put our snowshoes on! But we knew we were prepared for anything. For the complete trip report, see Part 17 at [www.national.com/rap/nepal/index.html](http://www.national.com/rap/nepal/index.html). ☺

**Comments invited!** [rap@galaxy.nsc.com](mailto:rap@galaxy.nsc.com) —or: Mail Stop D2597A, National Semiconductor P.O. Box 58090, Santa Clara, CA 95052-8090

**BOB PEASE** obtained a BSEE from MIT in 1961 and is staff scientist at National Semiconductor Corp., Santa Clara, Calif.



## Bob's Mailbox

**D**ear Bob: I once had a problem identical to what Jeff Siefske mentioned (ELECTRONIC DESIGN, Feb. 16, p. 18). The way he described it, his circuit did not originally have the power-supply common connected to the line cord green wire.

Often supplies have 0.01  $\mu$ f or so from each side of the ac line connected to the common to reduce conducted EMI. If the common is not grounded it floats to 60 V rms, with enough current available to give a nasty shock and also blow RS232 inputs. At 0.01  $\mu$ f, about 0.5 mA is available. (That sounds like "only 60 V," but that is 84 V peak. If you have a 0.01- $\mu$ F cap charged up to 80 V ac peak, the momentary surge will be larger than 0.5 A, which is capable of blowing a lot of computer inputs—and semiconductors in general. You can make inputs that will survive such an 80-V surge, but you'd have to add resistors and diode clamps. And it takes some real engineering, some significant expense, and some extra board size to protect the inputs. /rap) Another good reason to not pull out the third pin on your power cords!

- **Jim Harman** (via e-mail)
- **Pease:** Uh, yeah! Or, you might avoid this by not doing hot-plug connections, if you don't know what's going to happen. Thanks for the comments, Jim.

**Dear Bob:** I have a story you might be interested in about "Autosave Stuff" (ELECTRONIC DESIGN, March 2, p. 20). Several years ago, a coworker and I were writing a document (using MS Word) and had autosave turned on. We were using many of the features of Word, including drawing and autoshape options for many complex drawings. Autosave worked nicely, saving everything every 30 minutes. This went on for two days. At the end of the second day we tried to load from the autosaved file and found it corrupted.

(Ouch! And you trusted it to work, so you never checked it before you trusted it. Presumably, it had worked in the past but started to go bad when you needed it. If I have an important document, I will "save to file" and also occasionally "save to template," which is less likely to get scrambled or erased. I also print out important pages on paper, where it's easier to proof-read with full accuracy—and slightly less likely to burst into flames. /rap)

We never saw any warnings. And it did not save each new autosave in a separate file. Ouch! Now when I see that an autosave is engaged, I manually save to the file name + a sequence number.

It gives me the feel of being back in 1969 and resaving every 10 lines entered when logged onto timesharing on a mainframe. All that time and technical progress, and we still can not depend on the hardware/software beyond the keyboard and monitor, be it a mainframe or a PC.

- **Charles Ryan** (via e-mail)

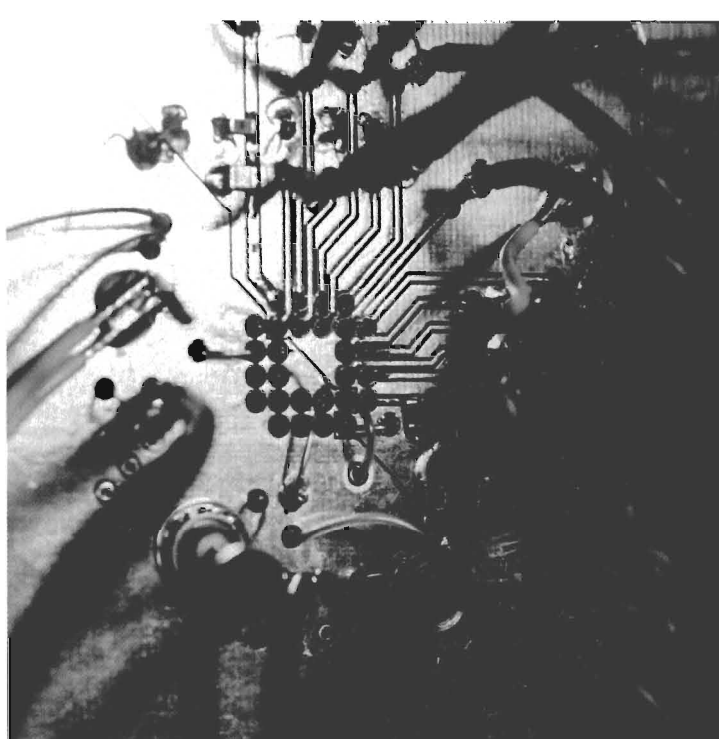

- **Pease:** Yeah, I guess you can hardly trust any computers. Not even analog computers... or punched cards?

**Dear Bob:** Autosave is one of those things I keep turned off in MS Word. Consider this scenario: I have just done one of those stupid things where I somehow delete a block of text (maybe click on delete instead of cut). The phone rings and I am on one of those long support calls. So autosave soon saves the corrupted document. Of course there is a .bak copy, isn't there? Sure. But 10 minutes later, while I am still on the phone, autosave again saves my corrupted document and saves a backup copy of it as well.

(Ouch! I never had that problem. /rap)

Sure, I could still come back and undo the changes. But I am less likely to remember to do this than I was to manually save my work at regular intervals. What is needed is a pop-up reminder.

- **Frank Delts** (via e-mail)
- **Pease:** Hello, Frank. PC Write Lite used to provide that, too, on request.

**MENTAL MATH STUFF** • Here are the answers to the brainteasers in my "What's All This Mental Math Stuff, Anyhow" column (ELECTRONIC DESIGN, March 30, p. 18). For more details, see [www.national.com/rap](http://www.national.com/rap).

1. 25.0400 miles, or 132,211.087 feet
- 1b. I don't know, but maybe soon
2. 80 or 80.05 mph
- 3: Three or four double-pole double-throw switches are fine (see my Web site for a full explanation)
- 4: 12.48999600
- 5: 14 or 13.97 milli-inches  $\infty$

**Comments invited!** rap@galaxy.nsc.com —or: Mail Stop D2597A, National Semiconductor P.O. Box 58090, Santa Clara, CA 95052-8090

**BOB PEASE** obtained a BSEE from MIT in 1961 and is Staff Scientist at National Semiconductor Corp., Santa Clara, California.





# What's All This License Plate Stuff, Anyhow?

**L**et's call this the License Plate Game, because that's the easiest place to get three nearly random letters. You start with three given letters, and you have to make them into a word. And you start with eight points.

If you add one (or more) vowels to the beginning or end of the letters, that costs you one point. Or if you have to add one or more consonants to the beginning or end of the letters, that also costs you a point. If you have to add some (one or more) vowels and also some consonants, your score is down from eight to six points. It doesn't make any difference how many letters you add. But that's just the start.

If you have to change the order of the given letters to turn it into a word, that costs you two points. And/or if you have to insert any new letters into the original letters, that costs you two more points. So if you have to do all those things, you are down to just two points. But if you can't make any word at all, then it's not too surprising that you get zero points.

You can see that this is not at all like sudoku, where every move is just logical. In this game, you have to be able to manipulate letters and make words. And as a first hack, I'd say the scoring is based on elegance.

Now, that isn't the end of the scoring. Let's say that by using those rules and procedures, you can make a word that's worth six points, or whatever. But you can win one bonus point if you can take the given letters and make one word using only added vowels and make one word with only added consonants. And that is a nice little challenge. I think it's fun. I got the concept of this game from an old friend, Karen, but she started with six points. I think eight is fairer.

There is one more side rule. If the three given letters already make a word, that doesn't count. You have to change or add something to make some new word. Now, there may be only 20<sup>3</sup> combinations of letters that will show up on license plates. But that's pretty good. 8000 is enough. Note that "ABC" is not the same as "CBA" or "BCA," so it's not too boring.

How can two or more people play in a competitive way? I haven't really thought of any firm rules, but obviously you have to have some plans for allowing enough time for all the players to find a word or words. Then at a suitable time, somebody has to decide who states his solution. Maybe the player with the highest number of claimed points goes last. What words are



considered legal? Well, you can set your own house rules and pick any dictionary you choose. Myself, I tend to accept plurals, but not proper names, such as geographical places.

Here's an example. RED is already a word, and you can easily make REED or REND. However, those involve splitting the original letters, so those would make just five points. Therefore, SHRED is better, as it does not involve splitting. And those seven points, added to the bonus point (for the one word you made by only adding consonants, and the other word you made by only adding vowels) brings you back to eight.

When there are awful combinations like JXZ, you concede quickly and go on to the next car—the next set of letters. At least, I can't make a word with J, X, and Z. If you find any combinations of letters that seem hard, send them to me as a challenge! 🙄

**Disclaimer:** This game specifically is not recommended for drivers, who may get distracted and forget where they need to turn off or when they need to put on the brakes. Avoid playing this game if you get distracted.

**Comments invited!** rap@galaxy.nsc.com —or:  
Mail Stop D2597A, National Semiconductor  
P.O. Box 58090, Santa Clara, CA 95052-8090

**BOB PEASE** obtained a BSEE from MIT in 1961 and is staff scientist at National Semiconductor Corp., Santa Clara, Calif.



## Bob's Mailbox

**D**ear Bob: Just read your recent "Mailbox" column (*ELECTRONIC DESIGN*, March 16, p. 20). You commented on a reader (Mike Smolin) who stated that his tire dealer put nitrogen in his tires. There are good reasons for this. The main advantage is that nitrogen is dry, whereas compressed air has a lot of water vapor in it. (*Ordinary compressed air may have some water vapor in it. A little. It may or may not have much. /rap*) When the tires get hot the water boils and increases the pressure in the tires, which affects handling, braking, etc.

• **Cliff Harris** (via e-mail)

• **Pease:** How often do you run your tires above 150°F? Racers may. I don't. I doubt if you do. So do you want to pay \$8 or \$12 for nitrogen in four tires? Yuppies may want to have "the very best," even if they can't tell the difference. Just like the Emperor's New Clothes.

NOTE: Even at 220°F, water does not boil in an atmosphere with 30 psi of pressure. So how much "vapor pressure" will they add at 150°F? I'll guess 3 psi if you have a lot of water in there (1/4 cup) and perhaps 1 psi if you had 1/8 teaspoon. For sure, on my VWs, the tires don't get above about 150°F, no matter what. The temp rise is barely 25°F above ambient, and even in a desert, it rarely gets above 125°F. If they are that hot, your 30-psi pressure has already risen to 34 psi, and that's not a big deal (on my Beetle, from 27 psi to 31). If you are running your tires hotter than that, well, you probably have other problems. You said there were "good reasons." Good reasons for the mechanic? Like what—boat payments? I'll just keep air in there. For racers, balanced inflation is very critical, so they use dry nitrogen to prevent any 3-psi imbalances.

**Dear Bob:** My thoughts are that the new tires always go on the front. I put a very high premium on being able to steer. (Yeah, but these guys argue that being able to steer only a little, and to skid not at all, is better. Better for them, maybe. /rap) Only a real yahoo would put the new ones on the rear of a front-wheel-drive car. (That is exactly what these guys think is safest. /rap)

I miss rear-wheel-drive cars because they always wore the rear tires faster. Then you would put the new ones up front and have nice new ones for steering and half-worn ones on the rear for decent traction. I like a little oversteer! Always hated front-wheel-drive (a Saab, two Toyota Camrys) because of its sometimes abrupt understeer. (Yeah, but that is about all you can rent these days. /rap) Remember that stupid myth about front-wheel-drive: "If you go into a skid, floor it—it'll pull you out?" Talk about crapola.... (Check. Have you seen my pretty good

book, *How To Drive Into Accidents...? Check it out at www.transtronix.com. I put at least half of the chapter on skidding on the Web. Comments invited. /rap*)

I've been driving Subarus for years, now, and you can't beat four-wheel-drive. Plus the torque is biased towards the rear, so you can kick the rear around if you want to.

• **Nick Allen** (via e-mail)

• **Pease:** Hello, Nick. Well, you and I agree that we want good traction under our drive wheels. But a lot of other people wrote in to say that it is dangerous to have worn tires on the

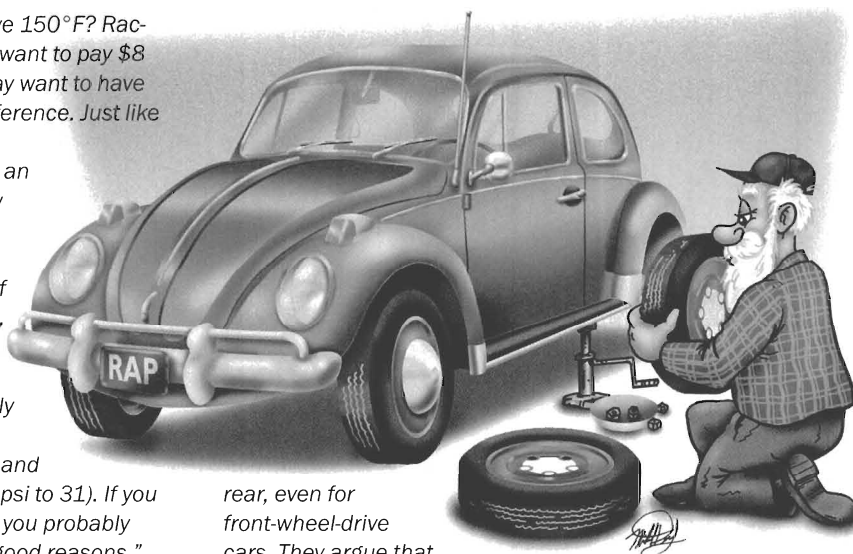

rear, even for front-wheel-drive cars. They argue that most drivers are used to understeer and plowing. But under braking or under cornering with slack throttle (especially on rainy or slick surfaces), this can change to oversteer and a nasty skid. Maybe most drivers would be safer if they avoided that. Maybe they're terrified of getting into skids and don't know how to get out of skids.

The chances that I will own a front-engine car or front-wheel drive are negligible. But that's what some worrywarts worry about, and apparently the tire companies do, too. So if you take in your car, and they insist on putting the new tires on the back, you will have to overrule them by rotating your own tires, front to rear, right in their parking lot and thumbing your nose at them! (And then you have to be extra careful, for a while, not to skid into any accidents.) ☺

**Comments invited!** rap@galaxy.nsc.com —or: Mail Stop D2597A, National Semiconductor P.O. Box 58090, Santa Clara, CA 95052-8090

**BOB PEASE** obtained a BSEE from MIT in 1961 and is Staff Scientist at National Semiconductor Corp., Santa Clara, California.



# WHAT'S ALL THIS "ERROR BUDGET" STUFF, ANYHOW?

I was just on the phone explaining how to do an "error budget" analysis on some fairly simple circuits to a young engineer. Later, I mentioned this while I was visiting with my friend Martin, and he said he had been quite surprised

when he found that many engineers in Europe were quite unfamiliar with the concept of an "error budget." How can you design a good circuit without being aware of which components will hurt your accuracy?

When I was a kid engineer back in 1962, my boss George Philbrick gave me a book on differential amplifiers by Dr. R. David Middlebrook, and he asked me to do a book review. I studied the book, and it was full of hundreds of partial differential equations. If you wanted the output of a circuit with 14 components, you could see a complete analysis of how each component would affect the output offset and gain. Each equation filled up a whole page. It did this several times.

Yet it didn't offer any insights into what's important. I mean, is  $\beta \times d(R1)$  more important than  $R1 \times d(\beta)$ ? In retrospect, I'm glad I didn't submit any critique of that book. I woulda done more harm than good. Such a mess! Even now, it would be hard to write a critique on a book that was so true, but so unhelpful.

Things are much simpler now that people are mostly (but not entirely) designing with op amps. The best thing is that the output offset and dc gain and ac gain errors are largely orthogonal. An "operational" amplifier does perform, largely, an "operation" based on what task you ask it to perform when you "program it" with Rs and Cs. If the offset varies, the gain does not, and vice versa. We all agree that it's very helpful that you can compute what the performance will be with almost no interaction. No partial derivatives.

Now, let's take a look at a couple of applications—real circuits—and their tolerances within an error budget. Here is an amplifier to magnify the  $I \times R$  drop of current through a  $0.1\text{-}\Omega$  resistor and bring it back down to ground. Figure 1 shows a conventional differential amplifier, with the common mode up at +12 V. The gain of -20 will bring the  $1.0\text{ A} \times 0.1\text{ }\Omega$  signal down to a ground level. If the current is 0.1 A, the output will be 0.2 V, "small-scale." A full-scale current of 1 A will bring the output up to 2.0 V, which is suitable to send to a detector or analog-to-digital converter.

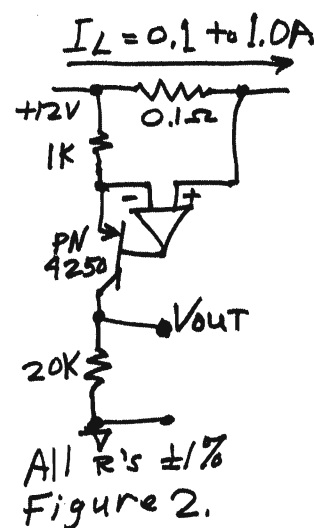
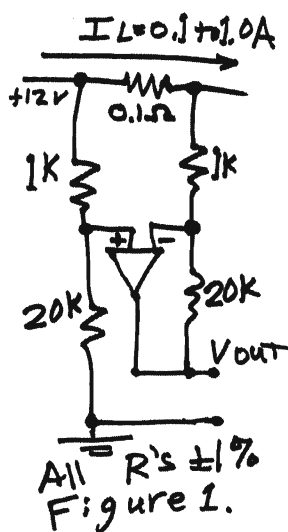

Let's select an op amp like the LMC6482B, with low offset voltage less than 1.0 mV. (There are other versions of this amplifier with less than 0.35 mV, but let's select an intermediate model.) This 1 mV does cause 21 mV of output error. This op amp has less than 20 pA of  $I_B$  at all temperatures, so at least that's negligible. (Bipolar op amps might have small  $I_B$  errors, but you'd have to check it.)

Now let's see what the resistors add. Assuming all Rs have a 1% tolerance, the gain of (2.0 V per A) has a tolerance of  $\pm 3\%$ . This would cause  $\pm 60$  mV at full scale, but only  $\pm 6$  mV at "small scale" (0.1 A). This may be acceptable.

Then let's consider the common-mode errors. If R4 has a 1% tolerance, and it has 11.4 V across it, the 1% tolerance could cause a 114-mV error. By symmetry, a 1% error of each of R1, R2, R3 can cause another 114 mV! Added together, the common mode could cause an output error of 456 mV! That's about  $\pm 1/4$  of full scale—even for small signals. That doesn't look so good to me!

It's true that if adjacent 1-k $\Omega$  resistors are inserted, they're likely to match within  $\pm 1/2\%$  so the probable error between the pair

might cause  $\pm 60$  mV, and the  $\pm 1/2\%$  matching between the 20 k $\Omega$ s would cause another 60 mV. That added to the 21 mV from the  $V_{OS}$  would add to 141 mV.

Some textbooks teach you that you should add these errors arithmetically to 141 mV. Others point out that they could

be added in an RMS way, so that  $60 + 60 + 21$  mV = 87 mV. Typically, this might be true. But the worst case of 141 or 456 mV might be more realistic. I mean, if you're going to build 1000 circuits, and most of them are better than 141 mV, what are you going to do with the 400

circuits that are worse than 141 mV? And, that's still 7% of full-scale....

You could go shopping for 0.1% resistors, but they aren't cheap. You could put in a trim-pot to trim the error to (no offset error) for small signals. But as you may have noticed, a trim-pot has to be properly trimmed. And if that pot is accessible, it could someday be mistrimmed, and it would have to be corrected, in some awkward calibration cycle. Most people want to avoid that trim-pot. Before we decide that this 141 mV is unacceptable, let's look at another circuit.

Figure 2 shows an alternative circuit with the same gain, 2.0 V per A, using a PN4250 or 2N4250, a high-beta pnp transistor. What does the error budget look like? The same op amp causes just 20 mV of output error. The 1% resistor tolerances cause the same gain error, 60 mV at full scale, or 6 mV at "small scale." The newly added transistor adds ( $-1/3\%$ ) max from its alpha, or less than 7 mV, at full scale.

What is the offset error due to common-mode rejection ratio (CMRR), or due to resistor mismatch? Nothing. Zero. The transistor doesn't care about the voltage across it. There are no resistors with 12 V across them.

So the offset error is  $\pm 20$  mV, due primarily to the amplifier's  $V_{OS}$  (which could be reduced), not  $\pm 400$  mV. This little circuit has greatly reduced errors compared to Figure 1, even if Figure 1 had a couple bucks of 0.1% resistors. This may be acceptable. Even the offset errors could be reduced to 7 mV by selecting the LMC6482A.

So we have seen that circuits with similar functions can have completely different "error budgets." I love to recommend amplifiers with high CMRR. But depending on cheap 1% resistors can hurt your "error budget" a lot more than you'd suspect. 

**Comments invited!** [rap@galaxy.nsc.com](mailto:rap@galaxy.nsc.com)

—or:

Mail Stop D2597A  
National Semiconductor  
P.O. Box 58090  
Santa Clara, CA 95052-8090

**BOB PEASE** obtained a BSEE from MIT in 1961 and is staff scientist at National Semiconductor Corp., Santa Clara, Calif.



## Bob's Mailbox

**D**ear Bob: When looking at datasheets or application notes that have the schematics of an IC in them, I often see very strange components; transistors with two, three, or even four collectors or emitters, and a component that looks like a capacitor where one plate is a resistor. The LM675 datasheet on page 5 has both of these. For example, check out Q12, Q15, Q16, and R23. Application Note 446B on the LM12 internal design also has these. On page 3, Figure 3, Q3 and Q4 have two collectors and a short line through an extension of the base that seems to be shorted to itself. And, R32 in the lower right has one of these resistor-capacitor hybrids but nothing connected to the plate. I'd like to learn more about what these mean and was wondering if you could write a column about them and/or point me at some references that talk about them.

- **Len Fischer** (via e-mail)
- **Pease:** Hello, Len. Okay, I finally found a few minutes to peek at the LM675 datasheet. It is perfectly logical. The pnps that seem to "have four collectors" really do have four collectors. Whatever current is sent into the emitter winds up at the four collectors, split into about four equal parts. I've been doing that for many years. My LM331 has done this since 1977, and the LM301 and LM741 have done this since the early '70s. So has Tom Frederiksen's LM324. If you wanted to see more about this, you could look at [www.designarrays.com](http://www.designarrays.com), which is Hans Camenzind's Web site. The resistors with the bar above them are pinch resistors. You can learn about them also at Hans' site. They have lousy tolerances and lousy tempcos, but they're better than nothing. This is nothing new. You're just starting to notice them, but they have been around over 30 years. And, I finally got a chance to look at the LM12 datasheet. The resistors with bars are pinch resistors. The bar across the collector of a transistor represents a ring that collects current when the transistor saturates. I had to do some digging around to find the answer to that one.

**Dear Bob:** Have I had fun. I recently took up a course on arc welding (one needs to stay entertained), and wow! This is something I think every electronics engineer should experience. Just you, a 25-V, 150-A arc, a mask, a stick, and a little voice in the back of your head going "PULL THE POWER! PULL THE POWER! IT'S BAD! VERY BAD!"

- **Dan Williams** (via e-mail)
- **Pease:** Yup, there sure are a lot of femtoamperes in a 150-A arc! "Billions and billions!" I welded up a tandem bike, starting from two bicycles, when I was a kid. I rode it several hundred miles, and it was stolen just

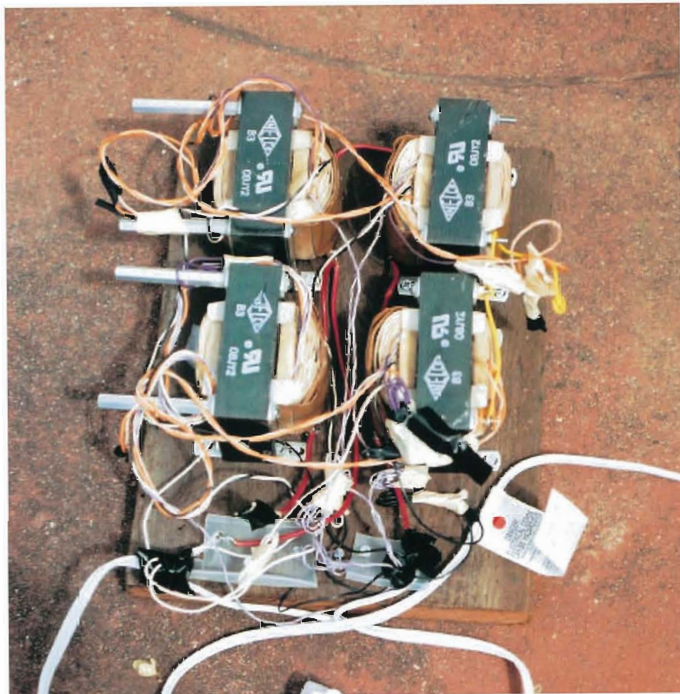

about the time the main welds began to go. Yeah, welding is a useful art—like baking or cooking.

**Dear Bob:** (Forwarded to Bob by Ted Hardin, senior applications engineer at NSC) Could Bob Pease comment on "the restriction of the use of certain hazardous substances in electrical and electronic equipment (RoHS)"? Are there that many old lead-filled scopes going into landfills? The new no-lead solder really sucks. My technicians having to use this stuff are cursing me out. It is too stiff, doesn't wick well into thru holes, and always looks like a cold solder joint. Are there any good choices for no-lead solders?

- **Dan Mohr** (via e-mail)
- **Pease:** Hello, Dan. I agree, it is unfortunate that we have to use inferior solder. I'm not sure exactly where it says you can't use solder containing lead for experiments. But exactly where that crosses the line to "not using it for production," or for material that is to be shipped out, is something I have not heard. I'll look into that. But why ask me? Ask Dear Abby. Ask Kester or other people that make solder. I don't sell any solder. Let me know if you find anything good. Meanwhile, get a hotter soldering iron!

**Dear Bob:** I just finished reading "What's All This Bivouac Stuff, Anyhow?" (ELECTRONIC DESIGN, April 13, p. 20). So, what's all this snowshoe stuff got to do with *Electronic Design*, anyway? (If I froze to death, I couldn't write any more columns. That's what. /rap) In short, planning and preparation. That's the key to success in any venture, and the lack thereof can be the key to failure. Works the same for manufacturing electronic products or climbing mountains. Thanks, Bob!

- **George Gerwick** (via e-mail)
- **Pease:** Check! /rap

Comments invited! [rap@galaxy.nsc.com](mailto:rap@galaxy.nsc.com) —or: Mail Stop D2597A, National Semiconductor P.O. Box 58090, Santa Clara, CA 95052-8090

**BOB PEASE** obtained a BSEE from MIT in 1961 and is Staff Scientist at National Semiconductor Corp., Santa Clara, Calif.



## What's All This Theft Stuff, Anyhow?

**M**y wife got stung recently. Somebody stole her computer's battery charger from her checked bags at San Francisco International Airport. Then I got stung the same way.

As I was leaving my hotel in Phoenix, Ariz., I tucked my computer's battery charger into the outside pocket of my unlocked suitcase and left to go to Sky Harbor International Airport. I didn't put the charger in my knapsack to carry it with me onto the plane as I usually do because the computer had a good charge and I didn't expect to do much typing. After I arrived in Los Angeles and went to my hotel, I looked for my charger. It wasn't there.

So, I was able to borrow some charge from my buddies' chargers and do just a little typing for the next couple of days. I survived. When it happened to my wife, she was annoyed. Ever since it happened to me as well, I've been very annoyed.

The pattern is obvious. The people who run the X-ray machines at the airport are passing on the word—by some kind of sticker or chalkmark—to some accomplices who know where to reach inside the unlocked suitcases and grab a \$100 item. Most travellers won't even report this to police, but I will. So far, several colleagues have said that battery chargers have been stolen from their checked baggage, too. So, I'm not just imagining things.

If you're carrying a laptop and you have a battery charger, or anything of value that is metallic, don't put it in your unlocked suitcase. Carry it with you. Yes, I know a pound is a heavy load to add on to your carry-on baggage. But the avoided inconvenience is worth it.

If your battery charger is stolen, report it to the police. Eventually, we will nail down the culprits. They're hurting us \$100 at a time, but we will apprehend them. Or scare them into stopping. If you check in your baggage at an airport, the guys who run the X-rays know what's in it. Some of the guys at the arrival airport might like to steal what's in your baggage, but they don't have X-ray machines. So you can tell who has the info.

I could buy an FAA-approved padlock and put it on my suitcase. But that's a joke with a soft-sided suitcase. If I put a \$20 lock on a \$15 suitcase, the thieves would be all the more curious about what I had. They'd just slash through the side. Normally I don't keep anything of great value in my suitcase.

Specifically, I always carry my lecture notes in my briefcase. I would never put them in my checked baggage. Even if

they're of no value to anybody else, they're very valuable to me, as I couldn't do my lectures without them. Even if they were delayed, I'd have problems. Except for a clean shirt, there's nothing in my suitcases that I can't do without for a day. I could carry a clean shirt in my briefcase, but I don't.

I have a hard-shell suitcase, but there's no place to add an external lock. Security? At an airport? No further comment. I read recently that 87 thieves have been caught at airports. What about the other 870 (out of the 87,000 honest airport workers) who are still unapprehended? They may be honest most of the time, but a few of them are surely ready to grab a valuable item. My suitcases met up with one of them.

In general, I don't leave valuable things in my car. I know how easy it is for a guy with a coat hanger to get into a car. If I'm going to see the dentist on my way home, I bring my briefcase with my laptop into the dentist's office. 📁

**Comments invited!** rap@galaxy.nsc.com —or:  
Mail Stop D2597A, National Semiconductor  
P.O. Box 58090, Santa Clara, CA 95052-8090

**BOB PEASE** obtained a BSEE from MIT in 1961 and is staff scientist at National Semiconductor Corp., Santa Clara, Calif.



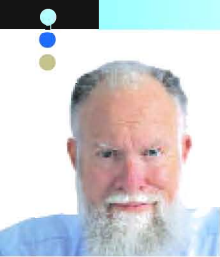

**Pease**PORRIDGE

**BOB PEASE**, *Contributing Editor*

• • • rap@galaxy.nsc.com

## Bob's Mailbox

**H**ey Bob: This motorcycle road-racing engineer can tell you that the whole nitrogen-fill thing is usually a load of you know what (see "Bob's Mailbox," March 16, p. 20). The first thing they do when demounting/mounting your tire is to spray the entire bead area with copious amounts of soapy water. Repeatedly. So all the dry nitrogen in the world isn't going to amount to a hill of beans when the environment inside the tire is quite moist. To make it worth anything you'd need to use a commercial non-water-based tire mounting lubricant. So for those who need the very best, they should make sure that they get the right lube with that nitrogen!

- **Scott Traurig** (via e-mail)
- **Pease:** *Hey, Scott, I forgot about that!! Maybe if they ran dry nitrogen through the tire (in and out?) after it was mounted, they could eventually dry it out. Inflate/deflate, nine times? Absurd!!! Maybe if they used some solvent that was not water-based, they could avoid the moisture. Maybe racers do that. I mean, I understand why they do want dry air—to minimize changes in inflation. Would they use some kind of rubber cement? Next time I buy a tire, I'll stand there and watch them mount it. Then if they wanted to sell me dry nitrogen, I'd ask why they wet it down first. But nobody has ever asked me if I wanted nitrogen. Not yet. Thanks for being so observant. I don't buy tires very often or have them remounted. I usually bring in a flat and tell them I'll be back tomorrow for a new tire....*

**Hiya Rob/Bob:** I'm currently doing an undergraduate thesis on reference circuits at the University of New South Wales, Australia. My search on bandgap references brought me to your page and the page about Bob Widlar. I just wanted you to know that it is rather refreshing to see engineers with personality and flair, and hopefully I will be able to enjoy what I do when I finish my degree as much as you guys. All the best.

- **Min Sun** (via e-mail)
- **Pease:** *Hello, Min. When I came to NSC, slightly over 30 years ago, Bob Widlar was just preparing to bring out the LM10. That was one hell of an op amp with 85 transistors. I am still lecturing about the latest and greatest version of the LM10 op amp this week (as I write this) and next week. And about its reference. When you graduate, if you think you got "personality and flair" and circuit talent, the analog engineering world needs you!*

**Dear Bob:** Just read your piece on dielectric absorption (DA) at [www.national.com/rap/Application/0,1570,28,00.html](http://www.national.com/rap/Application/0,1570,28,00.html). Very useful information there. However, I still have a question. How does one know the DA of conventional surface-mount caps? (It's easy. Charge it up to +10 V, for perhaps a second. Then short it out for a few milliseconds with a switch. Watch its

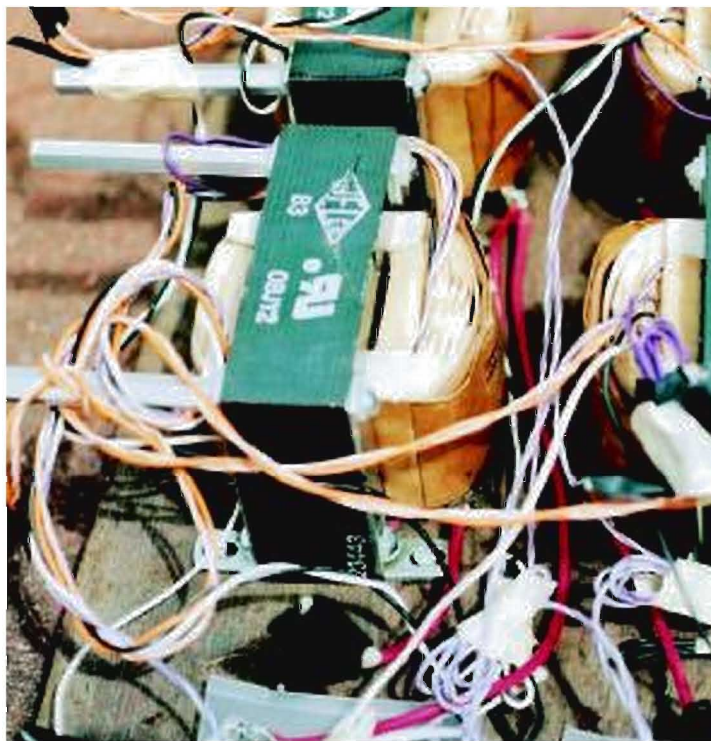

$V_{OUT}$  rise up, using a high-impedance voltmeter, or a good op amp with  $I_B$  less than 1 pA. If it rises a few mV, it's NPO. If it rises dozens of mV, that's some inferior ceramic. /rap)

Our application uses an LF398M sample and hold, with a 0.01- $\mu$ F cap for an acquisition time of about 20  $\mu$ s and hold step of 1 mV. But there are no curves in the Typical Performance Characteristics graph for surface-mount caps. Any idea on that, or is it time to build up a test rig?

(The test rig is very simple. Set up the LF398 with +10-V input, and sample for a second or two. Then go to hold. Then set the  $V_{IN}$  to zero, and put in a short sample pulse, perhaps a few milliseconds. Watch its  $V_{OUT}$ . There will be a big difference. The LF398's leakage of perhaps 50 pA will cause a leak rate of 5 mV per second. That is good enough. Note: If you do not charge the X7R cap up to 10 V, then the lurch after it is shorted will not be bad, and it would be hard to tell an X7R from a COG. /rap)

The input signal is coming directly off an AD622 instrumentation amp connected to a photodetector. And the signal level is about 10 mV. (The LF398 would do a better job if there were a preamp ahead of it to bring that 10 mV up to 100 or 200 or 500 mV. /rap)

- **Dexter Francis** (via e-mail)
- **Pease:** *Hello, Dexter. Most 0.01- $\mu$ F ceramics are not NPOs, and they have lousy DA (soakage). Ask your purchasing people what they bought/are buying—most likely, X7R types. NPO ceramics that are 0.01  $\mu$ F are found in 1206 packages (3.2 mm by 1.6 mm by 1.2 mm tall). You can look it up in DigKey—and they cost \$0.40 to \$0.90 in quantities of 100! Most 0.01s are in a size 0204 or 0306 and cost a dime or less. They would be X7R or Y5V. And they have lousy DA. ☹*

**Comments invited!** rap@galaxy.nsc.com —or: Mail Stop D2597A, National Semiconductor P.O. Box 58090, Santa Clara, CA 95052-8090

**BOB PEASE** obtained a BSEE from MIT in 1961 and is Staff Scientist at National Semiconductor Corp., Santa Clara, California.

ED ONLINE 12948

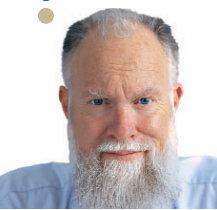

**Pease**PORRIDGE

**BOB PEASE**, *Contributing Editor*

• • • rap@galaxy.nsc.com

## What's All This Penny Stuff, Anyhow?

A friend wrote to me to complain about a new proposal to lock out individual Internet users. It seems like the issue is costs versus access. Big companies would be able to send and receive e-mails faster and cheaper than individuals.

If this plan comes closer to reality, I will complain more vigorously.

"I don't usually write to congressmen, but I do when it's important. Right now, I'm not sure this is important. Not yet," I replied to my friend.

"I would not mind paying a penny for every e-mail I send. I would even pay, reimburse, my company, NSC, a penny for every personal message I send," I continued. "In the last two months, I have sent over 1000 e-mails, and let's say half are personal. Would I change my e-mail habits if I had to pay \$2.50 per month? Heck, no. I spend more than that on stamps."

I wouldn't even mind paying a penny for every search I do. I mean, every search I make takes away several seconds of my life as I wait for the results. So I don't search for things lightly.

By the way, I did find some things in a recent search that weren't there a year ago. I usually use *dogpile.com*, but I must admit, *google.com* did find the lyrics to Shango's "Day After Day (It's Slippin' Away)" when Dogpile did not. "What can we do with a bushel of wet gold?" the group sang in 1969, when the song hit #57 on the national charts.

I would be delighted if all the spammers had to pay a penny per message. That might cut them back a lot. I'd vote for that. I won't approve of any volume discounts for them. And, a penny per megabyte per addressee would seem fair. Why would we protect the pigs who clutter up the airwaves? (Or, okay, wires.)

You're familiar with the idea that some people wouldn't stoop to pick up a penny. But picking up pennies, one per second, even if I had to stoop separately for each one, could pay me \$36 per hour—and that's not bad wages. Furthermore, these are pennies with no tax, so each one would be worth 1.7 cents or so. So, pennies aren't trivial.

Nor is my time trivial. I could save a few pennies per day if I drive slower, but that would waste a few minutes a day. I am holding at 65 mph as a reasonable compromise. I used to drive

at 68 mph, and I will again if gas gets below \$2.99. But I am jealous of my time.

As for computing access, I think this proposal is dumb. Somebody will squash it, sooner or later. I already have high-speed access when I'm at work. My company pays for it. When I'm at home, I have a mediocre slow modem, but that's okay with me. Most people who aren't willing to pay for a lot of fast access get slow, cheap access. That's okay with me too. I can't see a big deal about what you pay and what you can get. I don't think that's a real problem.

**TYPING TRICKS** ¶ I just used my left thumb on the space bar—which is contrary to good typing practice. But when your right hand is doing several other tasks, backspace and end, it may be okay.

Did you see in my column that many computer guys make @ by hitting the shift key with their left little finger and reaching over to the 2 key with their right index finger (ELECTRONIC DESIGN, Aug. 4, 2005, p. 20)? I must say, I do. I can do it the other way, but it is a forced deal.

Hey, do you know what's funny? My stupid computer has locked up (for 45 seconds) about once every 20 minutes for the last week. And I just noticed that it has stopped doing that. That sure is fine with me. I have tried a dozen tricks. I also have asked several computer experts to help. They tried, but it did no good. Now, it seems to have gotten better at a random time, and for no good reason. (Merde.) ☹

**Comments invited!** rap@galaxy.nsc.com —or: Mail Stop D2597A, National Semiconductor P.O. Box 58090, Santa Clara, CA 95052-8090

**BOB PEASE** obtained a BSEE from MIT in 1961 and is staff scientist at National Semiconductor Corp., Santa Clara, Calif.

ED ONLINE 12978







# What's All This C-R Stuff, Anyhow?

A resistor is a resistor, and a capacitor is a capacitor, right? Maybe, and maybe not. I'm doing some research in audio circuits. I've heard all the scientific claims that if two circuits measure the same, they ought to sound

the same. This claim is refuted by the observation that they don't sound the same. That's a pretty convincing rebuttal. I gotta believe it.

I'm an analog and measurement guy. If somebody says some audio circuits don't sound the same, I bet I can measure the difference. I thought of the old claim (by people with "good ears") that electrolytic capacitors in C-R coupling networks don't sound the same as high-quality film capacitors in an ordinary audio circuit.

I could set up some C-R coupling circuits and measure the differences in the outputs, if any (Fig. 1a). The capacitors might be polystyrene, mylar, or electrolytics (1  $\mu$ F and 100 k $\Omega$ ). I could use some precision differential amplifiers to see the "error voltages"—the difference between the inputs and the outputs. Yeah, I could do that.

But I'm a lazy guy. I can see that same "error voltage" if I merely swap the R and the C and look at the voltage across the capacitor (Fig. 1b, basic low-pass filter). It's a matter of viewpoint—what point you define as ground. I could watch those small error voltages on an ordinary scope and compare them, and I could even subtract them. So I set that up.

This filter has a f (3 dB) of 1.6 Hz. Shouldn't that be far enough away from 20 Hz at the low end of audio frequencies? I put in 120-Hz sinewaves, triangles, and square waves. It was kinda boring. I couldn't see any difference. Then I cranked the square wave down to 12 Hz.

The two waveforms were different. They matched for the first 20 ms, and then the electrolytic had more curvature (Fig. 2, lower trace) as if its early capacitance was 1  $\mu$ F but later changed to 30% bigger. I've used a lot of capacitors in my day, but I never expected the capacitance to change oddly with frequency like this. Would this change if I swapped scope channels? Nope.

What if I changed the R or C values? Well, I'm an old analog computer guy, and I didn't have to put in more capacitance. I just changed the virtual frequency back to 120 Hz. The capacitors may

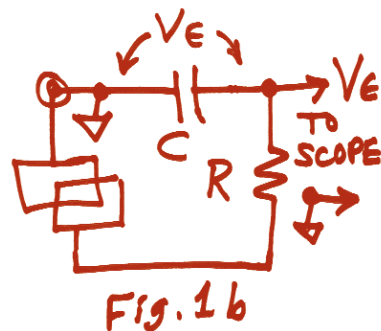
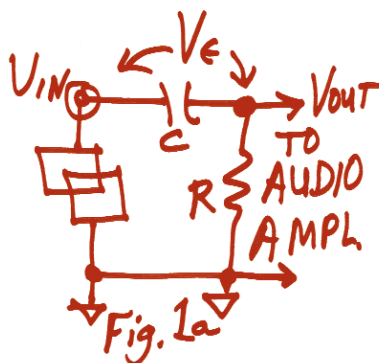

not be perfect, but when the errors are very small, can anybody hear them? And will anybody care?

That may lead to a test where even guys with good ears can't hear the electrolytics as they claim they can. I'll build up some circuits with National's new ultra-linear LM4562 audio operational amplifiers, which have less than 0.00003% distortion at 1 kHz. (For the LM4562, go to [www.national.com/rap](http://www.national.com/rap) and search for LM4562 after Sept. 8.) I'll set up some A-B comparisons and measurements.

Can we hear the difference between mylar and poly? Can anybody hear the difference? I can't. But maybe I can show that in a good circuit, nobody can hear the difference between mylar and poly. Or paper. What about 1- $\mu$ F ceramic? Comments later.

If you're an audio enthusiast, you may be interested in attending my Master Class at the Audio Engineering Society Convention in San Francisco, October 5-8. For more details, see [www.aes.org](http://www.aes.org). While I'm there, I'll present a lot of audio experiments that you can use to evaluate circuits and components. Y'all come! 🎧

Comments invited! [rap@galaxy.nsc.com](mailto:rap@galaxy.nsc.com) —or: Mail Stop D2597A, National Semiconductor P.O. Box 58090, Santa Clara, CA 95052-8090



Fig 2. Dashed line = Electrolytic

BOB PEASE obtained a BSEE from MIT in 1961 and is staff scientist at National Semiconductor Corp., Santa Clara, Calif.

**BOB PEASE** | CONTRIBUTING EDITOR

rap@galaxy.nsc.com



## Bob's Mailbox

**H**i Bob: In today's *Wall Street Journal*, there's a full article on A4 concerning hydraulic hybrids. It was developed by the EPA, which has a small lab. UPS trucks are being used for testing, but garbage trucks will be the first commercial use. *(I wonder what the standard "driving cycle" is for a UPS truck. It must be quite different from the EPA cycle for cars. Many parts of that cycle might have a lot of stop-and-go, but not all—not to mention the typical garbage truck cycle, which must be pretty wild. Gallons of garbage per gallon? But around here, garbage trucks already use hydraulics. So for their pickup cycle, they only need a small engine and a small accumulator. To haul to the dump, they need more power on the road. /rap)* Ford had been a partner but decided to go electric hybrid (with its Escape). This is good, but I feel that ultimately, electric is the most reliable, most efficient, and most elegant solution. Motors and controllers continue to improve *(Oh come on! Electric motors and controllers have been very good for a dozen years. Even 100 years ago, they weren't bad. It's just the batteries that are overpriced or undercapable, regarding range and life. /rap)* and even batteries (although I wonder about lithium). *(Everybody says Sony's superior Japanese engineering and Chinese manufacturing expertise are always the best. I guess Dell found out different... /rap)* Electronic Design had an interesting Techview on the Tesla Motors eCar (see [www.electronicdesign.com](http://www.electronicdesign.com), ED Online 13201). Now that looks like the future to me!

• **Dennis J. Eichenberg**

• **Pease:** *You just tell me when the price of those lithiums comes down by an order of magnitude. I think that may happen quicker than fuel cells coming down two orders of magnitude in price, but I'm not holding my breath. Some idiots were prattling along about the upcoming fuel cells replacing batteries in laptops. What a bunch of poppycock! (And you do know the etymology of that word!) Okay, I am in favor of many ways to conserve energy in vehicle operation. Electric cars can do it. Hybrids with batteries and even (in concept) flywheels can do it. Fine. Hydrogen fuel cells as a hybrid with batteries? Great, if we can afford them. Supercapacitors? Well, fine, if they work. Now this morning on NPR, I heard about a new demo truck from UPS. It uses hydraulics and compressed nitrogen for short-term energy storage. The preliminary claims are a 70% savings on energy. Presumably this is for some urban cycle. Well, that's fine by me! Anything that works! /rap*

**Dear Bob:** We've been soldering by hand for well over 50 years between my technician friend and I. *(I've been soldering for over 50 years all by myself. /rap)* We have tried several "new solder formulations that comply with RoHS and WEEE directives. The best replacement, from specifications and perform-



ance, is the IA-423 formulation (Sn/Ag4.7/Cu1.7), which is eutectic like Sn/Pb37, and makes a nice clean-looking joint provided sufficient flux is used. This solder requires a nominal (10°C) increase in tip temperature or increased tip-contact time. Also working well is Kester's Sn/Ag3/Cu0.5 formulation. Although non-eutectic, this solder "wets" later than its leaded predecessors and flows through holes better than any leaded solder we've used. Final finish is not nearly as "cold looking" as some others. Both of these formulations work very well for hot-air rework and assembly of surface-mount devices, which is even more critical than through-hole these days. It is worth noting that the IA-423 formulation falls under patent 5,527,628 (July 1993, USA Only), which covers the joints produced (Sn/Ag3.5-7.7/Cu1.0-4.0), and the Kester formulation is patented (JP 50 50 289, March 1993). Non-patented alloys, such as Stannol TC (Sn/Cu1.0), produce the confusing, inferior-looking "cold" final finish that was referred to in your June 22 column (see ED Online 12630). Perhaps there is some patent paranoia that is holding the lead-free world away from these quite usable alloys. *(I will check them out. Thanks for the advice. /rap)* I build my own prototypes to this day, even as a department head. I find soldering quite therapeutic.

• **Martin Mayer**

• **Pease:** *I've been doing a lot of solder recently, and it still feels nice. /rap* 

**Comments invited!** [rap@galaxy.nsc.com](mailto:rap@galaxy.nsc.com) —or:  
Mail Stop D2597A, National Semiconductor  
P.O. Box 58090, Santa Clara, CA 95052-8090

**BOB PEASE** obtained a BSEE from MIT in 1961 and is Staff Scientist at National Semiconductor Corp., Santa Clara, California.



# What's All This PLL Stuff, Anyhow?

I can't believe it took me so long to write this column. I designed some good, low-frequency phase-locked loops (PLLs) about 33 years ago and wrote them up but never got it published. When I moved from Philbrick to National 30

years ago, I got some good voltage-to-frequency converters going, using the new LM331. I also wrote application note AN-210 (still in print) about 1978, which you can see at [www.national.com/an/AN/AN-210.pdf](http://www.national.com/an/AN/AN-210.pdf).

I had a 10-kHz voltage-to-frequency converter. Testing it was a slow process, as the test technician had to trim the frequency to 20.0 Hz at 20.0 mV of  $V_{IN}$ . He also had to trim to 10,000.0 Hz at 10,000.0 mV, using coarse, medium, and fine trim pots. By multiplying the frequency by a factor of 10 to 200 Hz, I got a resolution better than 0.01% of full scale in much less than 1 s. So, it made a much better throughput with faster testing.

Later, a guy asked me for some help on a "low-frequency" PLL. I asked how low. He said 20 MHz. I explained that as far as I was concerned, 20 Hz was a low frequency. I can do PLLs much lower than 20 Hz. I can do 200 or 20 mHz, and if I was challenged, I could probably do a PLL at 20  $\mu$ Hz. I later made a 200-MHz PLL, controlled by a 5-MHz crystal clock. It was... challenging.

I was reminded of this when my wife asked me to take a cookie sheet of cherries down the cellar stairs to the freezer. I told her, "And I have to be careful to not flip them all over." When I'm walking up and down the stairs in the dark, I recall that I'm walking like a PLL. I lock my speed, frequency, and phase to that of the stairs going by. I don't need to see what the stairs are doing every millisecond. I can feel where I am.

When I'm running up and down the stairs, I rely on my PLL skills to put my feet in the right places (see "What's All This Conditioning Stuff, Anyhow?" at [www.electronicdesign.com](http://www.electronicdesign.com), ED Online 9726). Of course, running up and down stairs is only good for your health if you don't trip, fall, and crash.

Here at National, somebody put up placards saying, "Use the handrails to walk on the stairs safely." Whenever I see that, I immediately take my hand off the handrails and continue to concentrate on walking down the stairs carefully.

When we went hiking in Nepal to the Annapurna Sanctuary in October 2005, we knew there would be a lot of stone steps. I counted them carefully. On the last two days, we descended 8820 stone steps from Ghorapaani to Birethanti. These steps are known as Gurung Staircases, and famously so. See the complete story at [www.national.com/rap/nepal/annapurna.html](http://www.national.com/rap/nepal/annapurna.html).

Over the 14 days of the trek, we ascended and descended 35,510 stone steps. In the Annapurna area, the step sizes are fairly consistent, so you don't have to worry so much about the



Bob, Vic Scheinman, and Jeff Nilles stand 12,000 feet below the summit of Mt. Annapurna. This place, at 14,000 feet, is about 17,500 steps up from where the trekkers left the cars. (photo by Jeff Nilles)

step size. But you still have to pay some attention to where you place your feet. However, don't expect consistent step sizes in a house or hotel in Nepal. They often change wildly!

When we went on linear seminar tours about four years ago, we used to tell audiences to avoid using PLLs when they wanted a clock with low jitter. Now we tell designers to use a good PLL and engineer the loop filters carefully for a clock with low jitter.

NSC has a good Web site on PLLs at <http://webench.national.com/appinfo/wireless/webench/index.cgi>. It can help you engineer your loops. Some of the advice offered for 2400 MHz also may be applicable at 2400 mHz. I haven't exactly told you much about how to engineer good PLLs, but I may have pointed you in the right direction. These Web sites can be helpful. ☺

Comments invited! [rap@galaxy.nsc.com](mailto:rap@galaxy.nsc.com) —or: Mail Stop D2597A, National Semiconductor P.O. Box 58090, Santa Clara, CA 95052-8090

BOB PEASE obtained a BSEE from MIT in 1961 and is staff scientist at National Semiconductor Corp., Santa Clara, Calif.

ED ONLINE 13785



# What's All This Sallen-Key Stuff, Anyhow?

Recently, people in various publications have been pointing out that using an ordinary op amp in a Sallen-Key filter can cause problems. A typical op-amp circuit, as shown in Figure 1, can have a

frequency response that rolls off nicely above 1 kHz, at 12 dB per octave, down to -40 or -50 dB. Then the response may roll back up or stay flat at higher frequencies.

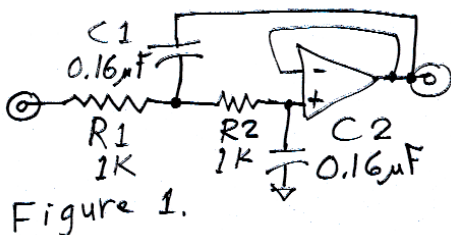

If you choose a fast op amp with high  $I_b$ , you might choose low values for R1 and R2 to minimize error due to  $I_b \times R$ . This might lead you to use large capacitors, which are more expensive.

The real problem is that at high frequencies, the input signal couples through R1 and C1 and forces current (potentially, several mA) into the op amp's output. Real op amps usually have very low  $Z_{OUT}$  at dc. But at high frequencies, their ac  $Z_{OUT}$  isn't characterized. Yet if you ask any op amp to put out current at higher frequencies, and the gain keeps rolling off at 6 dB per octave, that indicates that the  $Z_{OUT}$  is going to roll up with frequency like an inductor.

It's not hopeless. There are several things you can do. First, select an op amp with higher input impedance and lower  $I_b$ , maybe a CMOS op amp with  $I_b$  less than 1 pA. This will let you pick higher values for R1 and R2. In turn, this lets you use smaller (cheaper and/or higher-quality) capacitors for C1 and C2.

So if R1 was a low value (1k) and fed a lot of current into the output at high frequencies, first, increase the R values by a factor of 10. This improves things tenfold. If you have a 1-kHz rolloff frequency, for example, the capacitors could decrease from 160 nF to 16.

Now, do it again! Go to 100 kΩ and 1.6 nF. The theory of the filter works just fine when each resistor is increased by a factor of  $n$ , and the caps are likewise shrunken by  $n$ —not rocket science. Now the rolloff goes down a lot further, and the capacitors are smaller and cheaper.

**NEXT PROBLEM** ¶ I don't have any 1600-pF capacitors in my lab. That's a mongrel value. So again, we add in another scaling factor of 1.59. We can now use 1000-pF capacitors and 158k resistors. Those are easy to find. Thus, you can arbitrarily scale the capacitors and resistors, up or down, and maintain the same response. I usually avoid capacitors smaller than 200 pF.

**NEXT TRICK** ¶ Don't just take R1 as a fixed entity: Break R1 into pieces. If you had 159k, you could break it into 9k (5%) and 150k (1%). Then from that juncture, throw in C3 = 0.01 or 0.0047 μf to ground. This now makes a three-pole rolloff. That will further roll off the frequency response of the filter, and it will further decrease the amount of current fed into the output via R1 and C1. This added R-C will add even further to the rolloff and high-frequency attenuation, if you want a lot of that.

**NOTE** ¶ If you're using LM324s because they're cheap and because you have 1/4 LM324 just sitting around, consider that the LM324, because of its class-B output stage, is one of the worst op amps for a Sallen-Key filter. That's because its output impedance is potentially soft.

To minimize this problem, connect a suitable pull-down on the output to one of the rails, perhaps 15k to  $-V_S$  (or in some cases to  $+V_S$ ). This can cut down on the amount of "feedthrough" by making  $V_{OUT}$  stiffer. We have many other amplifiers, and all of them work better than the LM324.

Which op amps have inherently lower  $Z_{OUT}$ , and thus tolerate current fed in through R1 and C1? The NSC Webench site at [http://webench.national.com/appinfo/webench/filters/design\\_requirements.cgi](http://webench.national.com/appinfo/webench/filters/design_requirements.cgi) does a surprisingly good job of predicting how much the  $Z_{OUT}$  will hurt, so it's worth a try.

However, it won't let you substitute in different values for the Rs and Cs, and it won't let you break up R1 into two pieces or add C3. You'll have to model that in Spice (which I don't recommend) or make a breadboard (which I do recommend). 

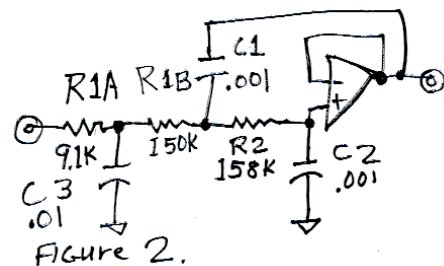

**Comments invited!** rap@galaxy.nsc.com —or: Mail Stop D2597A, National Semiconductor P.O. Box 58090, Santa Clara, CA 95052-8090

BOB PEASE obtained a BSEE from MIT in 1961 and is staff scientist at National Semiconductor Corp., Santa Clara, Calif.

ED ONLINE 13480



PeasePORRIDGE

BOB PEASE, *Contributing Editor*

• • • rap@galaxy.nsc.com

# What's All This Bicycle Stuff, Anyhow?

A friend wrote to me that flying a plane is like riding a bicycle. It took me about four seconds to rebut him: “No, flying a plane may be a little similar, but it’s much different from riding a bike.” A plane can fly fairly

stably with no controls. But a bicycle has to be steered and controlled so it doesn’t fall over.

And there’s a big difference between flying a plane and riding a bike (or motorcycle): If you want a plane to turn, you can quickly start banking and turning. But to get a bicycle to turn left, you first have to turn the handlebars to the right and wait for the bicycle to lean to the left. After that, you can start turning left. Motorcycle riders can maneuver faster than cars, but only if they know what’s coming. Drivers in cars can make unplanned maneuvers faster than cyclists.

It’s amazing that so many kids learn how to ride a bicycle. It really is tricky. After learning to ride a bike, driving a car is easy. That reminds me of some of the early work of George A. Philbrick. It must have been about 1942, when the war preparations were ramping up.

George got involved in training anti-aircraft gunners. He showed that it was quite hard to learn to aim a gun with an extra lag inserted in the aiming mechanism. But after the gunner learned how to handle that lag, he became a much better gunner once the lag was removed. So that was put into gunners’ training.

Well, riding a bike doesn’t exactly have a lag. But it does involve a challenging problem—having to steer left before you can turn right! That’s counter-intuitive. After a kid has learned to deal with that, driving a car is easy. As I’ve said, I wouldn’t want to teach a kid to drive a car if he hadn’t already learned to be a good bicyclist.

I like many things about my new mountain bike, a Specialized Rockhopper A1FS. But I can’t ride it no-hands. It really has no stability for that. I’m not sure if its good maneuverability is because of this instability or in spite of it. But since I don’t need to ride no-hands, I don’t complain much. But I have ridden many miles no-hands on other bikes.

Of course, one operating mode is worse than not using your hands: If you cross your arms on the handlebars, you will quickly crash. So don’t do it! If you just touch a finger to the handlebars and think hard, you might be able to avoid crashing, but be careful. Assume you will crash anyway.

**THE GREAT SKID DEBATE** ¶ The recent debate over whether or not the better tires should be put on the front or the rear of the car has been settled in favor of the rear. That’s

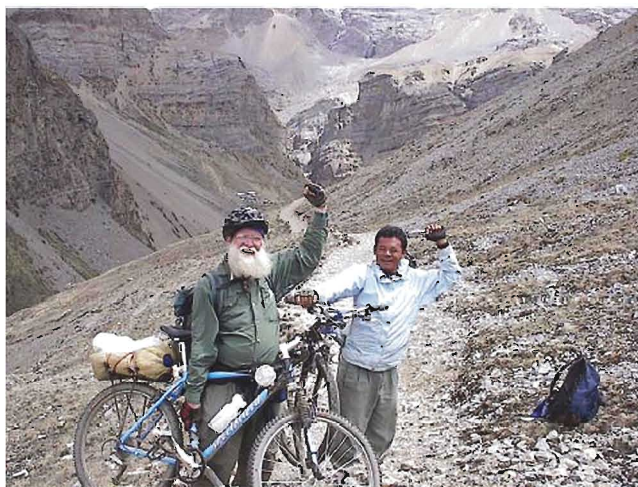

Jeff Fisher took this photo in June 2002 at 14,600 feet, looking down on Thorong Phedi (three tiny huts right above RAP’s helmet), just before we got up to the pass at 17,771 feet. Kalu Tamang, the guy in the picture, was our guide.

because skidding with the rear wheels is so “dangerous.” Yet we all remember riding our bikes down a slope, locking up the coaster brake, sliding the rear wheel stably, and steering just fine!

Remember to steer in the direction of the skid. So, rear-wheel skids aren’t so bad if we think about it and can steer quickly. Just don’t overdo it and rip up your tires—or your father’s lawn.

Our bicycle trek around the Annapurnas in Nepal (never higher than 17,771 feet) scheduled for last June had to be postponed. All five of us (even the sherpa) had too much work and couldn’t get the time off. We’ll try again in May 2007. Check out [www.national.com/rap/nepal/index.html](http://www.national.com/rap/nepal/index.html) sections 13, 14, and 15 if you’re interested in joining us. 🚲

**Comments invited!** rap@galaxy.nsc.com —or:  
Mail Stop D2597A, National Semiconductor  
P.O. Box 58090, Santa Clara, CA 95052-8090

**BOB PEASE** obtained a BSEE from MIT in 1961 and is staff scientist at National Semiconductor Corp., Santa Clara, Calif.

ED ONLINE 13566



## WHAT'S ALL THIS BEST STUFF, ANYHOW?

**Bob Pease**

CONTRIBUTING EDITOR

I've been working with precision op amps. Some have good linearity. Some are excellent. Some have high  $Z_{OUT}$ . Some have low. Some are bipolar, others are CMOS. The figure shows the basic test I've been using for linearity to exercise the output to 20 V p-p by applying a  $\pm 10$ -V sine or triangle wave to the signal input.

Meanwhile, the noise gain of 1000 ( $R_2/R_1$ ) magnifies the input voltage  $V(\epsilon)$  by a factor of 1000 so the scope can see (on a 5-mV scale) a 5- $\mu$ V signal in cross-plot mode. The noise can be as low as 5  $\mu$ V p-p, and you can see the distortion of just a microvolt or two riding along under the noise.

It's true that many engineers are interested in the total harmonic distortion plus noise (THD+N). However, the distortion riding along under the noise is sometimes important, even though an Audio Precision

can most easily measure THD+N.

I did some evaluation on the LM4562 precision audio op amp. Its noise for an audio bandwidth is down near 0.4  $\mu$ V<sub>RMS</sub>, and at least that's easy to measure. But I still had to measure the distortion at 1 kHz. The test circuit in the figure can't show the linearity of the gain at 1 kHz, only at 5 or 10 Hz.

That's because the ac error is so big, it isn't easy to see the distortion. For example, the LM4562's ac gain at 1 kHz is about 60,000. Not bad, but for a full output, the summing point error is 333  $\mu$ V, and it's hard to see if that is linear within a few microvolts.

### CHEATERS EVENTUALLY PROSPER

• So I decided to cheat. I used a small variable capacitor—a few inches of twisted pair, often called a “gimmick,” using teflon wires. I connected this from the  $V_{IN}$  to the

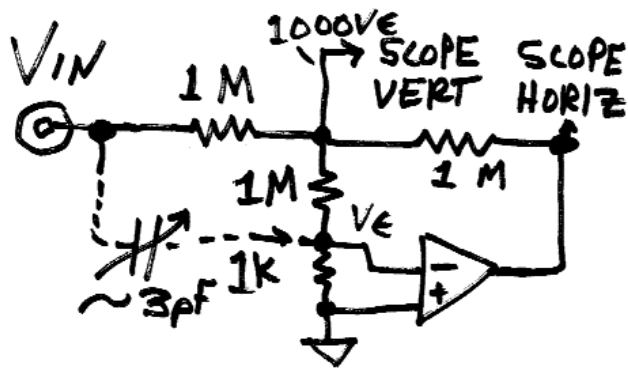

input of the op amp. As I wound up the wires, the ac component of the error voltage shrank a lot.

I kept increasing the frequency as well as the capacitance. Finally at 1 kHz, I got it down under 1  $\mu$ V of signal plus a few  $\mu$ V<sub>RMS</sub> of noise. This provided good insight into what the 1-kHz gain looked like. But why was the noise so big?

I realized that I'd been using this lazy man's gain test for so long, I wasn't paying attention to the way the noise of the 1k resistor (about 4 nV/ $\sqrt{\text{Hz}}$ ) was bigger than the op amp's noise. So, it was time to cut the impedance levels! I didn't rewire the circuit. Instead, I just slapped in 20k across each 1 M $\Omega$  and 20  $\Omega$  across the 1k. Of course, the capacitance had to be scaled up too, so I put in about 140 pF on top of the 3-pF gimmick.

This provided a definitely improved view of the distortion, with an improved noise floor. I could see that the ac distortion, even at 1 kHz, was somewhere well below 1/2  $\mu$ V p-p. But I still couldn't see exactly how low. So I

got mad and fed this signal into our HP3561A spectrum analyzer. This plainly showed the amount of the distortion, such as 71.45 nV at 2.2 kHz, with a 10k load. (It degraded to 200 nV with a 1k load.)

The combination of the subtracting and self-amplifying effects of my circuit, plus the ac cancellation, plus the high resolution of the spectrum analyzer, showed -159 dB of distortion at 2.2 kHz (second harmonic) when running the LM4562 at a 20-V p-p sine output at 1.1 kHz. This was the best distortion I have ever seen, and fortunately the best test circuit I have ever seen, or we wouldn't have been able to measure it. ☑

### Comments invited!

rap@galaxy.nsc.com — or: Mail Stop D2597A, National Semiconductor P.O. Box 58090, Santa Clara, CA 95052-8090

BOB PEASE obtained a BSEE from MIT in 1961 and is staff scientist at National Semiconductor Corp., Santa Clara, Calif.

ED ONLINE 14109

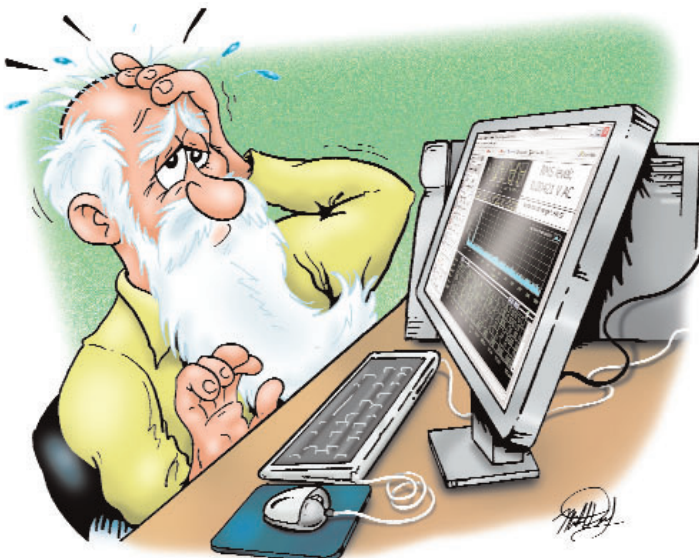



## What's All This Floobydust, Anyhow? (Part 14)

My old friend Robert M. Milne retired a few months ago as editor of *Electronic Design* after 23 years. RMM has been my main contact with *ED* for 15 years, ever since this column began.

Bob has been very helpful, and a really good sport, about editing my columns. He can slice a few words out of a sentence without wrecking it, or chop a couple of small sentences out of a paragraph without changing the meaning—quite an art. I will miss him a lot. He even tripped me up on technical errors and questioned me properly. I love the man.

Bob had fairly lousy health in the last few years, but a recent change of doctor has brought him some good advice: “Cut out the calcium channel blockers.” Now he is beginning to feel peppy, rather than like a zombie, so he can start enjoying his retirement. Maybe ducking the need to edit my column on deadline will even stabilize his blood pressure! Best wishes to you, Bob Milne. Keep questioning your doctors! Thanks for all the help and advice over those years.

**DOCTORING STUFF, PART 4C STROKE DIAGNOSIS** ¶ Many people know that in case of a heart attack or stroke, it's very important to get the victim to medical care very quickly, within much less than an hour. But what do we know about diagnosing such an unhappy person?

Defining a heart attack relies on asking the victim about various kinds of pain. Pain in areas near the heart can tell you that you should call 911. No comments on this today. But in case of a possible stroke, where a person may experience numbness or paralysis, particularly on one side of the body, what can we do as laymen?

First, ask the person to lift both arms and hold them out in front. Often, a stroke victim will be unable to bring up both arms or hold them up. They will droop. Serious clue.

Second, ask the person to smile! If the victim can't smile in a symmetrical way, you have another serious clue.

Third, ask the person to speak a simple sentence.

I know some people who are barely able to pass some of these tests in normal situations! But barring that, call 911 and describe these serious symptoms. The dispatcher usually will send an ambulance promptly.

Treating a stroke within the first hour gives the victim a good chance to recover. Somebody who trips or starts mumbling (worse than usual) may be okay. But if you aren't sure, ask these questions, call 911, and explain how the person flunked these

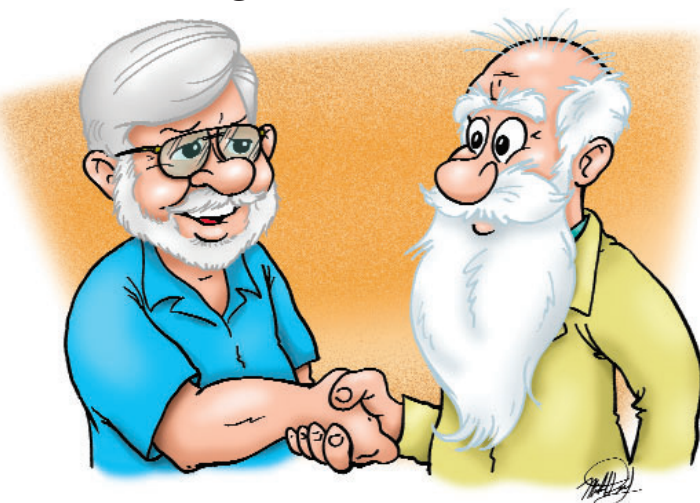

tests. The 911 dispatcher may ask other questions, like those at [www.strokecenter.org/education/jauch/02.htm#Chain](http://www.strokecenter.org/education/jauch/02.htm#Chain).

After all, every one of us is getting older by definition. And as all of our friends get older, the likelihood of somebody having a stroke increases.

**RELATED TOPIC** ¶ If you have medicines past their expiration date, please *do not* flush them down the toilet. Flushed medicines have been found to contaminate our waterways, leading to fish with hormonal afflictions, schizophrenia, and unhappy sex lives. Save those medications in a safe, locked place until a pharmacist or doctor tells you how to dispose of them safely. I keep most of my old medications in my freezer, so the effective expiration date is extended (except for aspirin, whose expiration apparently isn't extended by freezing). ☺

**Comments invited!** rap@galaxy.nsc.com —or: Mail Stop D2597A, National Semiconductor P.O. Box 58090, Santa Clara, CA 95052-8090

**BOB PEASE** obtained a BSEE from MIT in 1961 and is staff scientist at National Semiconductor Corp., Santa Clara, Calif.

ED ONLINE 14195

**BOB PEASE** | CONTRIBUTING EDITOR

# What's All This GetHuman Stuff, Anyhow?

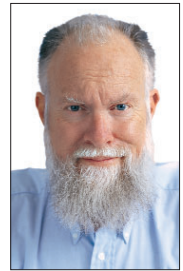

**W**e ordered a new refrigerator from Sears to replace our sick, dying 30-year-old icebox, and it was supposed to be delivered on December 7. The Sears salesman told us that we'd get a phone call about delivery on December 6. When Sears called, the operator said it would be delivered the next day

between 10 a.m. and noon. But the next morning, another operator called to say the refrigerator hadn't (magically?) arrived from the manufacturer, so we should wait a day or two. So much for JIT...

Since our icebox didn't come on Thursday, my wife Nancy waited most of Friday to see if Sears would call her with news about delivery. Finally, deciding to be proactive, she called Sears.

The first person she talked to tried to give her a runaround: "Oh, that was delivered on Thursday..." Nancy explained that no, it obviously was not delivered on Thursday (stupid computers...). The Sears person said someone "would call back in 24 to 48 hours" to tell her when it could be delivered.

Nancy signed off, and then she gradually began to fume. She finally followed the advice of a friend, regarding an airline that gave her some stupid advice: "Call the airline back again, and maybe you can talk to a different person who can give you a more reasonable answer—or an answer that you like."

(She once had called an airline whose clerk had told her it was impossible to change a ticket because it was a paper ticket, not an E-ticket.)

This is contrary to the recent saying that insanity consists of asking the same question over and over and expecting a different answer each time you ask it.

Recently, I've been asking my computer to do a simple task, and it refused to do it. So I would reboot, but I got no improvement. I would reboot one more time to finally get a reasonable response. Sometimes... maybe... sometimes, two or three more reboots.

So Nancy got back on line with a person at Sears who consulted her computer and said, "Oh, yes, the refrigerator will be delivered on December 10." Nancy queried, "But that is a Sunday. Do you deliver on Sundays?" Oh, yes.

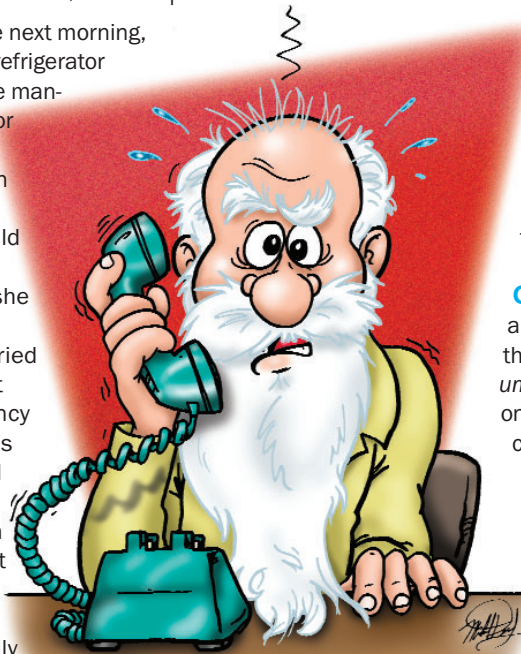

So it goes to show that when you're talking to a real person who is addressing a computer, you may be talking to the wrong person and getting the wrong answer. Sometimes, trying again is the right thing to do. (Meanwhile, we gotta give those delivery guys a nice tip for getting it delivered as fast as possible.)

**Get Out Of The Phone Tree** • There's a list of at least 475 major U.S. companies at the "gethuman 500 database" at [www.gethuman.com](http://www.gethuman.com). You can get simple instructions on how to talk to a real person at these real companies without wasting dozens of minutes on a dumb "phone tree."

Sometimes the instructions are as simple as "press 0" or "press # at each prompt" or even "don't press anything, don't say anything." It varies from company to company.

I forecast that the "future" doesn't belong to computerized phone trees,

except for the simplest information, or to "outsourced" help centers who try to "help us" from 6000 miles away. The "future" belongs to wise humans who can answer a phone, help us solve problems, and save us time.

It belongs to humans who can ask us the right questions so we can resolve the real problem quickly with a good answer, like "the refrigerator will be delivered between 3:30 and 5:30 p.m. on Sunday." Would you believe that? (And yes, it was.)

When people call or e-mail me, I do try to be very helpful or at least transfer them to someone who can be helpful. I rest my case. ☺

Comments invited! [rap@galaxy.nsc.com](mailto:rap@galaxy.nsc.com) —or: Mail Stop D2597A, National Semiconductor P.O. Box 58090, Santa Clara, CA 95052-8090

**Bob Pease** obtained a BSEE from MIT in 1961 and is staff scientist at National Semiconductor Corp., Santa Clara, Calif.

**ED ONLINE 14414**



**BOB PEASE** | CONTRIBUTING EDITOR

rap@galaxy.nsc.com

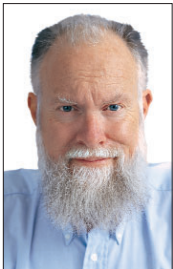

## Bob's Mailbox

**H** **Bob:** I was just reading your column in the Nov. 16, 2006 issue of *Electronic Design* ("What's All This SiO<sub>2</sub> Stuff, Anyhow?" p. 18) and had some insights. The silicon dioxide (SiO<sub>2</sub>) added to foods for anti-caking is a little bit different from sand. Chemically, it's the same, but it's made by dissolving SiO<sub>2</sub> in some really nasty acids and then flashing the acids off. What's left looks like a semi-solid fog. My old boss used to joke that it has "negative weight." You could keep scooping the stuff onto a scale for quite some time before you got much of any reading at all. There was no resistance to the scoop. It was like scooping fog out of a bottle. I think the trade name was CabOSil. When you blend it in with other powders, it keeps them from caking without adding really any weight. It also acts as a great thickening agent in oils and sauces or soups. Who would have guessed? *(I often put a little roux of butter, flour, and cream into my recipes as a thickener, but the SiO<sub>2</sub> foam would have fewer calories. On the other hand, the roux does add to the flavor. /rap)* As you pointed out in your column, SiO<sub>2</sub> is a marvelous material and is very useful in its many forms.

- **Steve Krueger**
- **Pease:** *It sure does help maintain our beaches! Where would our seashores be without it?*

**Hi Bob:** Regarding your article on SiO<sub>2</sub>—wow, finally. It has interested me that in the areas of food, drugs, and electronics, the role of passive components often is ignored. If something is nutritive or electrically conductive, volumes are written. Yet the passive components often are either barely mentioned or ignored. *(We can stop worrying about SiO<sub>2</sub> because it is soooo good! /rap)* Almost everything electronic—ICs, transistors, capacitors, resistors, battery cells, whatever—has a certain amount of conductors. Yet none of these would work without non-conductors (insulators) or at least dielectrics. *(For sure, and SiO<sub>2</sub> is one of the best. It has very low leakage when used to isolate input nodes, often better than 10<sup>15</sup>Ω, perhaps better than 10<sup>20</sup>Ω-cm—low leakage when used in capacitors and low dielectric absorption too! Maybe not quite as good as air... /rap)* In most (all?) electronic components, insulating material occupies more space, or area, or volume than conductors. *(Maybe not in rectifiers... /rap)* One of the most common non-conductors (or low conductors) is SiO<sub>2</sub>. Although sand is rarely pure SiO<sub>2</sub> in the natural state (most sand grains also contain a wide variety of other elements and compounds, such as the conductor aluminum), SiO<sub>2</sub> is probably the most common major component. Yet slightly inland Silicon Valley isn't called that because of its beaches (or relative lack thereof). Your column mentions silicon as one of the components mentioned in the ingredients of various food products. This, of course, is an FDA requirement. Golly gee, there doesn't appear to be any government organization that requires such detailed listing of the components used in transistors, etc. *(Such as arsenic... /rap)* As long

as you don't eat it, any such listing is entirely voluntary on the part of the manufacturer. When people start eating ICs, this situation may change. Chickens frequently eat sand. SiO<sub>2</sub> has little, if any, nutritive value. But chickens don't have any teeth. Sand grains serve as an abrasive material that breaks down other things they eat. Although SiO<sub>2</sub> passes through their bodies almost unchanged, it serves a useful mechanical function. *(When I was a kid, we fed our chickens calcium carbonate in the form of crushed shell fragments. That was designed to work much better than sand. /rap)* This whole subject really should be explored more thoroughly, especially in regard to electronics. Certainly, insulators (those things that do conduct electricity, but just barely), like air, are very useful. If you're working with very sensitive components or transmission items, like video, you don't want to wrap your ac lines around video cables, even if they're shielded, securely grounded, and insulated with a half-inch of rubber. *(Next time I am running video, I will wrap some ac power lines around them and see if I can tell any difference. /rap)* Yeah, a sandbox can do surprising wonders, but even this is imperfect.

- **John Rupkalvis**
- **Pease:** *Thanks for the comments. Best regards.*

**Hello Bob:** Your columns are sometimes amusing, but when will you finally switch to the metric system as used throughout Europe? *(Maybe when we get worldwide cooling. Do you happen to know the schedule for Hell freezing over? That is about when I will change over entirely. When driving in Germany or France, I think in kilometers and kilometers per hour. But even there when somebody asks me "How long is your foot?" I say it is about 1 foot long, or 1.1 feet with my shoe on. The reason we think in feet is because a foot is a useful measure. /rap)* Your columns about your bicycle treks only use feet. Do you prefer to use old units in electronics as well? *(I could use AB-volts and STAT-volts, but those are a little too obscure. But I suppose I could start using them... /rap)* How old-minded would that be?

- **Istvan Cocron**
- **Pease:** *About 65 years. Even in England, many older people don't like using the metric system. An old man in England wouldn't buy a kilogram of meat or half a kilogram. He would buy 454 grams because that is what he needs. And he would certainly buy a pint of beer. When Hell freezes over, and the beer does too, then we'll consider changing. ☺*

**Comments invited!** rap@galaxy.nsc.com —or:  
Mail Stop D2597A, National Semiconductor  
P.O. Box 58090, Santa Clara, CA 95052-8090

**BOB PEASE** obtained a BSEE from MIT in 1961 and is Staff Scientist at National Semiconductor Corp., Santa Clara, California.

**BOB PEASE** | CONTRIBUTING EDITOR

rap@galaxy.nsc.com

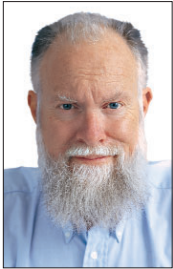

## What's All This Diffusion Stuff, Anyhow?

Once upon a time, if you wanted to make a junction transistor, you could start with a small seed crystal of pure germanium. Using Czochralski's 1917 methods, the crystal was gradually rotated and pulled out of a lightly doped N-type material and grown into a small boule. After suitable growth,

a small amount of acceptor impurity such as gallium was added to the melt, causing the germanium to form a PN junction. This was all consistent with the theory of William Shockley, published in June 1949.

The making of simple PN junctions was not that new. Then, Morgan Sparks of Bell Labs added a stronger impurity (antimony) to make a second closely spaced junction and keep the crystal growing. On April 12, 1950, the first junction (NPN) transistor was born, and all hell broke loose. Hundreds of inventions were added to make better transistors.

But this grown-junction transistor was hard to make, as the base area was barely 25  $\mu\text{m}$  thick and hard to connect to. Many efforts, both theoretical and practical, went into making practical transistors. Yet for a long time, the performance was still lousy, and the yields were still poor—a  $\beta$  of 40,  $f(\alpha)$  of 15 MHz, and breakdown of 25 V was considered amazing.

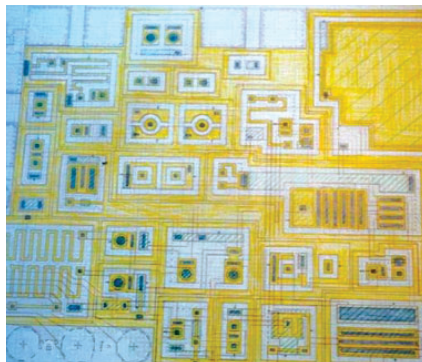

Circuit by Bob Widlar; layout by Dolores Talbert; book by Bo Lojek

### SOME WINTER READING ¶ Bo

Lojek, a research scientist at Atmel's Colorado Springs facility, chronicles the amazing stories of all kinds of brilliant research in his new book, *History of Semiconductor Engineering*. He also documents all of the human foibles that mark the industry's milestones.

Shockley, the "Fairchild Eight," and Texas Instruments are just some of the major players Bo describes. Jean Hoerni's planar process was a major advance, forcing the junctions to be made under a silicon-dioxide layer and greatly improving reliability under severe temperature conditions.

Dozens of minor companies made little advances. Some of these advances were lost forever, mere speedbumps on the way to progress. Dozens of engineers and scientists contributed ideas of varying degrees of helpfulness or uselessness.

The diffusion of gaseous impurities into a silicon wafer, masked by wax (or later by silicon dioxide), was a major factor in these improvements. Bo even includes the diffusion formulae on how you could make your own transistors, just as the original Fairchild researchers did. Planar process? Do it yourself!

Unfortunately, this book neglects to mention the pair of small, tasteful monuments to the contributions of Bob Widlar and Jean Hoerni at the foot of San Gabriel Court in Sunnyvale, right off Kifer Road, near Maxim's headquarters. I think Bo was too modest to mention that he had instigated the building of these monuments to the pioneers of our industry.

The bold Robert J. Widlar gets his own chapter and a half, showing how the "champion's" approach to pioneering improved (linear) circuits at Fairchild and later at National. His collaboration with Dave Talbert, who optimized the diffusion processes (in conjunction with Widlar's needs), is well documented.

When you're a pioneer, you may have to work extra hard to avoid arrows in your back and prove your ideas will really work. Widlar did that.

The book includes many drawings of classic inventions and photos of great people (and sheep), illustrating the stories. It also describes the business practices and human foibles that led to success (or fail-

ure), as well as the full panoply of human brilliance and stupidity.

**PICK UP A COPY ¶** Where can you get your own *History of Semiconductor Engineering*? Go to [www.amazon.com](http://www.amazon.com) and just punch in Bo Lojek. There are some good comments and reviews in there. Or, go to [www.electronicdesign.com](http://www.electronicdesign.com) and enter ED Online 14727.

And in the interests of full disclosure, I helped proofread his book and offered many corrections because I was entranced by his storytelling. Bo has a full 6-ft file on Shockley and many dozens of feet of files on the other players. He distilled the best stories down into this 380-page book. 📖

**Comments invited!** [rap@galaxy.nsc.com](mailto:rap@galaxy.nsc.com) —or: Mail Stop D2597A, National Semiconductor P.O. Box 58090, Santa Clara, CA 95052-8090

**BOB PEASE** obtained a BSEE from MIT in 1961 and is Staff Scientist at National Semiconductor Corp., Santa Clara, California.

**BOB PEASE** | CONTRIBUTING EDITOR

rap@galaxy.nsc.com



## Bob's Mailbox

**Hello Mr. Pease:** I've read somewhere that it can be a problem for the op amp to lose one of the supplies or use the wrong startup sequence. *(You are correct. A startup sequence can cause great trouble on the positive and negative rails. /rap)* Is it always a particular rail? Can you shed some light on the cause of this? Does it apply for bipolar and CMOS families?

• **David Smith**

• **Pease:** *You have proposed a tough problem, and I don't think there are any simple answers because there are only a couple thousand kinds of op amps that people use and a few dozen configurations for each. What a mess! Let's see if I can provide a general solution.*

*(A) Please try to avoid nailing the positive input of an op amp to ground, even if it should be "grounded." Bob Widlar has argued that even 1k is a good idea to prevent gross input currents from flowing.*

*(B) Here is a worst case. Set up a nice, healthy analog system with nice, healthy power supplies—say, ±15 V at 1 A. Connect an op amp as load with its positive input grounded and with 30 Ω of load from the +15-V bus to the -15-V bus. Now to get in trouble, connect the ground and the positive rail. Refuse to connect the -15-V supply to the -15-V load. The 30-Ω load would try to pull the negative power-supply bus toward +13 V and feed 480 mA through the 30-Ω resistor to pull the op amp's negative rail above its positive input—not a good idea. Many op amps will blow up quickly if you try this. LF356 biFETs and LM324s will probably blow or be badly damaged. Many bipolar and CMOS op amps, too.*

*(C) A partial solution is to take the load (the operating circuit and system) and connect anti-reversal diodes across the power-supply busses of the load (the system) so the negative supply can go barely 0.8 V above the ground bus and the positive supply can go barely 0.8 V below the ground. 1N4004s would be good in most cases. I don't think you will need 1N5819s.*

*(D) Avoid connecting a wire short from the input of the op amp to ground. If you put at least 1k there, it will not add much noise, but it will limit the currents and prevent much harm.*

**Robert:** Thanks so much for speaking at the Audio Engineering Society conference in San Francisco in October. I was wondering how PPS film capacitors such as Panasonic's ECH-U series compare with the rest in your testing. *(Polypropylenes have had superior soakage (dielectric absorption) and superior leakage (Tau = several years) /rap)* I'm in an application where I have to use SMT, and I've heard that PPS does even better than NPO for audio signal paths. *(If you can use a big enough poly, it can sound better. If*

*you use NPO and you chintz because it's not big enough in C value, you can't blame it on the inherent quality of the dielectric. Many people use poly and other films where SMT is "required" because they are superior and worth it in terms of performance. Solder them in by hand. Have fun! /rap)*

• **Tyler Gleghorn**

• **Pease:** *Why are the PPS capacitors so good? Because they are polypropylene, which is a very superior dielectric. Some people think it's an octave worse than polystyrene. I think it is an octave better, for all the applications I have seen.*

*There are many manufacturers of polypropylene and very few now of polystyrene. Polypropylene is comparable to NPO for audio work, but you can get 1 μF or more in a reasonable package, whereas NPO/COG is only available up to 0.1 μF. However, many film capacitors such as poly aren't very available in surface-mount (SMT) format. NPO/COG is much better than poly for tempco, though for audio circuits, who's going to complain about -120 ppm/°C versus (0 ±30)? If you think you can hear any difference, I suggest you try some A-B-X testing. I don't think anybody can hear any difference in an audio circuit.*

**Bob:** I finally got to read your Nov. 6, 2006 article ("Bob's Mailbox," p. 18). I thought John Cook's comment on the two-chassis RCA studio amplifier was interesting. I'm sure that separating it into two chassis, one with the power supply, reduced hum due to magnetic coupling from the power transformers. *(Not to mention the transients when the rectifiers carry big surges of current for short times. /rap)* Years ago, my company made audio mixers for the television broadcast industry. We had mu metal shields on our microphone input transformers and a steel shield around our power transformer. The noise was great, until you brought up several channels. *(Ha! /rap)* The fix, developed by one of my partners, was to reverse both primary and secondary windings on every other channel. Phase was maintained through the transformers, since both were reversed. But as more channels were brought up, the magnetically coupled hum went down instead of up. *(And this was the input transformers (not the power transformers)? What a brilliant solution! I don't expect things like that to cancel out. /rap)* I always thought it was a clever cure!

• **Harold Hallikainen**

• **Pease:** *Yeah, fiendishly... Thanks for the comments.* 🍻

**Comments invited!** rap@galaxy.nsc.com —or:  
Mail Stop D2597A, National Semiconductor  
P.O. Box 58090, Santa Clara, CA 95052-8090

**BOB PEASE** obtained a BSEE from MIT in 1961 and is Staff Scientist at National Semiconductor Corp., Santa Clara, California.



## What's All This "Others Stay Lighted" Stuff, Anyhow?

The box of Christmas lights said "If one or more lights go out, others stay lighted." Yeah, sure. My wife bought several cheap boxes of 100-light strings, and they looked very nice. This year, she had great plans to drape them along a fence, which would look real pretty. But some of the strings were

dead—kind of frustrating when you want to put the lights up *now*.

I did some simple checks. If one bulb went open, the others in series went out. Yeah, 5-V double-anode zeners can keep the other lamps running, but that's not what you get when you pay \$1.06 for 100 bulbs. As I hadn't planned to do any troubleshooting, I had no tools or meters with me—not even an LED.

To avoid disappointing my wife, I had to get to work and fix them, that night, so she could impress some friends who were coming over. It wasn't a question of having spare bulbs. I had plenty. But I really didn't want to pull out all of the bulbs and test them, as that surely would have done more harm than good.

The bulbs' bases were flaky too, and unplugging and plugging would have ruined them. I didn't even trust the sockets! I finally found some lamp cord from an old lamp, a couple of nails, and some tape for insulation.

**TO THE TEST** • These 2.5-V bulbs would take a little overvoltage testing. So I pulled out the first and eleventh bulbs and shorted out that group with the wire and nails. I decided there was no lack of continuity. I went on to the group of 11 to 21, 21 to 31, and 31 to 41—still no effect. Oh, what I would have given for an ohmmeter or a voltmeter!

Finally, I shorted out bulbs 41 to 50, and the other 40 bulbs lit up nice and bright! Hooray. As I indicated on page 7 of my book on troubleshooting, "troubleshooting a series divider is sometimes a nice challenge"—yeah, if you can gain access to the resistor string, which wasn't easy in this case. I suppose I could have taken a pin and poked it through the insulation into the wires, but that's not so great.

I checked continuity between 41 and 45 and between 45 and 50, and both were open. I had at least two failures, so I had to be pretty careful making assumptions about binary searching! By this time, some of the bulbs were getting flaky. I set aside some bulbs as "not trusted" and threw out a couple as hopeless.

One bulb refused to light but apparently would pass current. Another bulb seemed burned. And, one bulb had a melted base. But finally I got all the strings working with minimum tools—just a wire and some nails.

I'm going to use a tiny test kit in my future Christmas decorating chores, probably a 4.7k 2-W resistor and/or a 1- $\mu$ F 200-V capacitor, as well as a couple of insulated alligator clips and safety pins. Meanwhile, trusting cheap foreign junk isn't always a good idea.



I'm not really mad at the bulbs' manufacturer. I just wish it was a little more truthful about the probable failure modes.

**CLASSIC LIGHT BULB TRICK** • Let's say you have a motor-generator set (hydro power?) to generate power and send it back into the 60-Hz grid. But you can't just connect your generator, as it's likely to be out of phase. Connecting it could blow a fuse or cause damage. What to do?

Tie the common of your generator to the grid and connect a couple of 120-V incandescent bulbs in series from your output to the grid. Adjust your power input to get your frequency close to 60 Hz, and then bring the phase as close as possible.

When you see the intensity of those two lights drop gradually to zero, you know the frequency is very close and the phase is very small, so you can throw the switch! Of course, this trick is only a little over 110 years old. No fancy phase meter is needed. This trick does the job. 

**Comments invited!** rap@galaxy.nsc.com —or:  
Mail Stop D2597A, National Semiconductor  
P.O. Box 58090, Santa Clara, CA 95052-8090

**BOB PEASE** obtained a BSEE from MIT in 1961 and is Staff Scientist at National Semiconductor Corp., Santa Clara, California.

**BOB PEASE** | CONTRIBUTING EDITOR

rap@galaxy.nsc.com

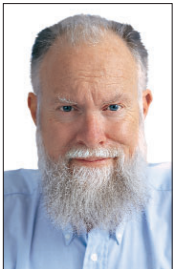

## Bob's Mailbox

**Hi Bob:** I have been following your silicon-dioxide ( $\text{SiO}_2$ ) articles and just saw Steve Krueger's response ("Bob's Mailbox," Jan. 18, p. 16) naming it under the trade name Cabosil. We use Cabosil at our company as a thickening agent for adhesives and epoxies during manufacture. When I had my first exposure to it, I was told it was small glass spheres. *(There are some epoxies with air-filled glass spheres, but that's different. Those are usually to yield lower dielectric constant and less capacitance. /rap)* I was concerned about the size of the "spheres" (breathing them in) and did some research. I found out it is the thickening agent for ketchup—the reason we had to go to squeeze bottles versus glass bottles (not an excess of tomatoes)? *(I have the impression that there is a lot of variance in the natural thickness of tomatoes or ketchup. My wife solves this by simmering until the texture is right, but Del Monte ain't gonna waste time like that! /rap)* I was shocked about glass or sand added but still love my ketchup.

- **Kevin Wagner**
- **Pease:** Check! Best regards.

**Hi Bob:** We are hoping you can shed some light on the issue of capacitor soakage *(or dielectric absorption, or "DA" /rap)*. We have read your publication on the subject entitled "Understanding Capacitor Soakage to Optimize Analog Systems" (see [www.national.com/rap/Application/0,1570,28,00.html](http://www.national.com/rap/Application/0,1570,28,00.html)). It was very helpful in understanding DA. We are currently struggling with an integrator that requires a reset to zero. After the reset, the integrator slowly goes in the direction of the previous output. This integrator is used in a closed-loop feedback circuit to create a very low-frequency high pass filter (0.01 Hz). We are using 1  $\mu\text{F}$  and 3.6 M $\Omega$  as the current RC values. After studying your article and trying many different dielectrics (polypropylene, PPS, polyester) *(First of all, get the "polyester" or mylars out of there. They are at least 10 times inferior. /rap)* we have found with all the capacitors we have tested that the internal soakage elements have a substantially longer time constant than what you have shown in your article.

- **David Muir**
- **Pease:** All capacitors—the ones I measured and the ones you measured—have many more time constants. You are quite right. I never intended Figure 4 in my article to cover all of the time constants—just the ones relative to 5-second shorting periods. I shoulda indicated with dashed lines that there are more Rs and Cs out there. On and on... I do not know which time constants will change (nor how much) as you short out the cap for longer times. Bigger Cs? How much? I can't guess. You will have to measure the actual data on your favorite caps. I know that on my favorite polypropylenes, as the time period goes out into days and weeks, if you let the soakage set-

*tle, it seems to subside into months. The observed leakage rates (half of which are probably soakage) goes out into years! No kidding!*

**Hi Bob:** I read with interest your "Mailbox" in the Jan. 18 issue, specifically the exchange concerning the metric system. You say "Even in England, many older people don't like using the metric system." I would say this is true even of younger generations here in the U.K. Although we are supposed to be metric, in keeping with the rest of Europe, the reality is that imperial measures persist in many areas of life. Typical examples of such measures would be miles for distances, miles per hour for speed, gallons for petrol, pints for beer, and pounds, ounces, and stones for weight. There have even been instances where market traders have faced prosecution for selling goods in imperial measures (to much public outcry, I might add). Imagine winding up in court for selling two pounds of bananas! *(instead of 0.9 kg... /rap)* The mind boggles. It seems to me, though, that the approach manufacturers have taken, particularly in relation to foodstuffs, is to sell things in imperial quantities but label them with the appropriate metric measure. So for instance, you can still buy a pint of milk but it will be labeled as 0.45 litres (or whatever the correct conversion is). *(Otherwise, you'd have to throw out a lot of pint bottles... /rap)* For my own part, I tend to use metric measures in my engineering life (simply because it's easier) and mainly imperial measures for everything else. I went to school at a time when the U.K. was just starting to move from one system to the other, and so I'm somewhat caught between the two stools, so to speak. If you asked me to imagine walking a mile or lifting 10 pounds, I could do so quite easily, but the same would not be true of walking a kilometre or lifting a kilogram. Also, if you were to ask someone over here how far it is to the next town, I think it is almost inconceivable that they would give you an answer in kilometres rather than miles. *(If the guy who asked me had French license plates, I could do it... /rap)* So, imperial measures are definitely not dead over here. We Brits value our independence. *(Bravo! And we too, until Hell freezes over, which could happen any week now. /rap)* And if you want further evidence of that fact, you should see how strenuously most of us are opposing the Euro!

- **Christopher Hill**
- **Pease:** Check! Best regards. 🍷

**Comments invited!** [rap@galaxy.nsc.com](mailto:rap@galaxy.nsc.com) —or: Mail Stop D2597A, National Semiconductor P.O. Box 58090, Santa Clara, CA 95052-8090

**BOB PEASE** obtained a BSEE from MIT in 1961 and is Staff Scientist at National Semiconductor Corp., Santa Clara, California.

**BOB PEASE** | CONTRIBUTING EDITOR

rap@galaxy.nsc.com

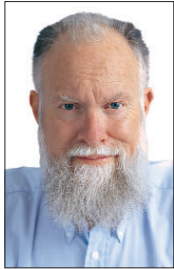

## What's All This Capacitor Leakage Stuff, Anyhow?

We all know that capacitors have a shunt resistance (leakage) and that leakage resistance should be pretty easy to measure, right? Wrong! I've measured a lot of capacitors for short-term soakage (dielectric absorption) per [www.national.com/rap/Application/0,1570,28,00.html](http://www.national.com/rap/Application/0,1570,28,00.html).

After the short-term soakage stops, it's possible (not easy) to measure the leakage. For example, if you charge a good cap up to 9 V for a few seconds, it will start discharging shortly for several millivolts. If you wait long enough, you may see leakage slow down to a few millivolts per hour. But you will see the long-term soakage. Is that different from the short-time leakage? Maybe not.

Now I will charge up some of my favorite low-leakage capacitors (such as Panasonic polypropylene 1  $\mu\text{F}$ ) up to 9.021 V dc (a random voltage) for an hour. I will read the  $V_{\text{OUT}}$  with my favorite high-input-impedance unity-gain follower (LMC662,  $I_{\text{b}}$  about 0.003 pA) and buffer that into my favorite six-digit digital voltmeter (DVM) (Agilent/HP34401A) and monitor the  $V_{\text{OUT}}$  once a day for several days.

Why did I choose 9 V? Because that's within the common-mode range of the op amp and the DVM at highest resolution. I keep the input ball hook connected to +8.8 V dc between readings. I also keep my left hand grounded to +8.8 V.

**DAY BY DAY** ¶ One of my e-mail colleagues had been monitoring some good 0.1- $\mu\text{F}$  polystyrenes, and he was impressed that they got down to a leak rate of better than a year after several months. Well, I could see that my polypropylenes had their leak rate improve even better than that in just a few days. Refer to the list of voltages below:

Day 0: 9.0214 V  
 Day 1: 9.01870 V  
 Day 2: 9.01756 V  
 Day 6: 9.0135 V  
 Day 7: 9.0123 V  
 Day 8: 9.01018 V  
 Day 9: 9.00941 V  
 Day 11: 9.00788 V  
 Day 12: 9.00544 V  
 Day 13: 9.00422 V

The first day after soaking for an hour, their leak rate was as good as 2.7 mV per day. Not bad.

If you had a 1 million- $\text{M}\Omega$  resistor across a 1- $\mu\text{F}$  capacitor at the 9-V level, it would draw 9 pA, which would pull down the capacitor 778 mV per day. All the capacitor types I tested were better than

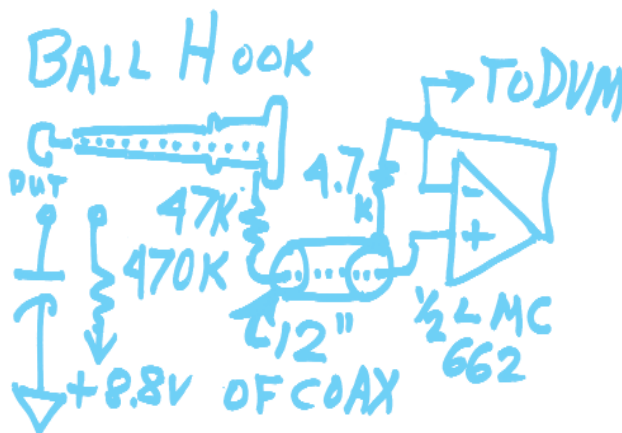

this, except some "oil-and-paper" caps that supposedly had special qualities for audio signals.

If you had a 10-meg-meg resistance, that would cause the cap to leak down 78 mV/day. With 100 meg-megs, it would be 7.8 mV per day. Several good capacitors soon began to leak slower than that. After a mere week, some of the best caps were leaking at a rate down near 1 mV/day. Quite good. So, what's the big deal?

The big deal is that a time constant of 31.5 meg seconds is one year! So any capacitor leaking less than 2.5 mV per day is leaking at a tau (rate) of 10 years or more. If you had to wait a few months to get this leak rate, well, that's not bad. But achieving this leak rate in less than two weeks is, I would say, quite good. Less than a day? Spectacular.

So I'm finding that good polypropylene caps are better than the best (old) polystyrenes, in terms of soakage or dielectric absorption (early or late) and in terms of leakage, early or late. Are Teflons any better? Not much. I may have to buy a couple to find out. ☺

**Comments invited!** [rap@galaxy.nsc.com](mailto:rap@galaxy.nsc.com) —or:  
 Mail Stop D2597A, National Semiconductor  
 P.O. Box 58090, Santa Clara, CA 95052-8090

**BOB PEASE** obtained a BSEE from MIT in 1961 and is Staff Scientist at National Semiconductor Corp., Santa Clara, California

**BOB PEASE** | Contributing Editor

rap@galaxy.nsc.com

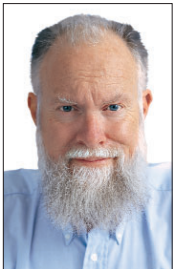

## Bob's Mailbox

**H**i Bob: Your tip on how to phase a generator into the electric grid would work ("What's All This 'Others Stay Lighted' Stuff, Anyhow?" March 1, p. 20). Phasing sets of the not too distant past used a couple of incandescent bulbs and a guy poised with his finger on the button, just as you said. I wanted to explain, however, that in the electric power industry, we go to great pains to discourage people from connecting a generator into their house wiring because of the potential safety threat it represents. Our linemen go to work on circuits expecting (but not trusting—more on that in a minute) that the area with the outage has only one source of feed—from the electric grid. Once they detect any other source, all repair work comes to an immediate halt while they troubleshoot it back to that source. (Okay, we sure agree. A bus that connects to the power grid must not be corrupted by a second, uncontrolled power source. But in the rapidly growing number of cases where people want to sell power back into the grid (and make the power meter "spin backwards"), you have to plan to get things disconnected! Obviously, an "inverter" that's trying to put a kilowatt back into the grid at 220 V will not be happy if the grid loses power and turns into 0.01  $\Omega$  to ground! /rap) That is what I meant by not trusting. Our work rules require testing it dead, sectionalizing, and then grounding prior to starting work. If they follow all those rules religiously, they should stay safe. (We agree. Safety first. Gotta have a high-reliability shorting bar! /rap) If they fail to follow all the rules, and they get hurt or killed by the unexpected source, then the homeowner has tragically caused the accident. For engineered systems where the homeowner is contracting to supply the grid via photovoltaics, wind, etc., we require installation of relays to detect a problem on the grid and automatically open an isolating breaker. (So, these relays and breakers open automatically and then require good planning before a decision to reconnect? /rap) It would be unusual for a generator to stay online during a widespread outage. But it is not impossible, and in almost 30 years, I have seen two or three cases where it did exactly that. The situation has to be just right (or just wrong! /rap), but it can happen. I hope your readers do not attempt to connect their generators to the grid. Maybe you can advise against it in a future column.

• **Gerry A. Akin**

• **Pease:** I guess that's a fair reminder. We need reliable relays, and plans, to disconnect any local power sources per strict rules that didn't exist 100 years ago. You are right. Professional installations have these relays and plans. Thanks for reminding us.

**Hi Bob:** Streetlights were once connected in series too, with an automatic shunting bar in case a lamp failed open. See the history section at [http://en.wikipedia.org/wiki/Street\\_light](http://en.wikipedia.org/wiki/Street_light). (Thanks for the historical info! It's kind of odd to think of an "anti-fuse" that goes short if overvoltage! /rap) See the brochure for constant-

current transformers (to feed such series strings) at [www.specialtytransformers.com/ST%20Acrobat/CCR%20BROCHURE.pdf](http://www.specialtytransformers.com/ST%20Acrobat/CCR%20BROCHURE.pdf) (That's quite weird! A transformer with moving parts! I guess fact is much stranger than fiction. /rap) and government spec (p. 11) at [www.wbdg.org/ccb/DOD/UFGS/UFGS%2026%2056%2019.00%2040.pdf](http://www.wbdg.org/ccb/DOD/UFGS/UFGS%2026%2056%2019.00%2040.pdf). For more on Christmas lights, see [www.plan-etchristmas.com/Minis.htm](http://www.plan-etchristmas.com/Minis.htm), especially the update at the bottom.

• **Jim Harman**

• **Pease:** This does seem to be a complete story about "self-repairing" Christmas lights. It seems as if the "SEMI-conducting" path to the wire has to be pretty reliable or it would short out and steal all the current away from the actual incandescent filament! I guess I gotta go connect up several examples of dead bulbs to a curve tracer to see what kind of non-linear stuff is in there. I wonder what ohms we will find...

**Hi Bob:** In the Feb. 15 edition, you refer to PPS capacitors as polypropylene. While I share your appreciation for polypropylene as ideal for audio applications, PPS refers to polyphenylene sulfide, a cat of quite a different color. (I had not appreciated the PPS material. I've never worked with it. /rap) PPS capacitors are available in surface-mount packages and are alleged to survive typical reflow processes satisfactorily. PPS as a high-temperature dielectric has a lot of appeal but unfortunately is very expensive and does not self-heal very well. We have at my company decided not to pursue manufacture of capacitors using this dielectric. I have no idea as to "sonic characteristics" of PPS capacitors. In spite of the fact that I play lead guitar in a country rock band with homemade (sand state) gear, I don't think that there is much, if any, difference in sound with various film capacitor dielectrics. (I tend to agree. In any well-designed audio equipment, all films will work pretty well.) I try to avoid discussions on the sonic differences of different capacitor types. Those discussions have often resulted in "flame-o-grams" from so-called "gurus," and I no longer try to add value to related newsgroups. It's definitely a "reader beware" environment on the Internet as far as audio and electronic music equipment is concerned.

• **Terry Hosking**

• **Pease:** It is also a difficult place to get any honest comparisons with any two kinds of audio equipment. Bringing up the concept of A-B-X comparison is just too horrifying for some of these grossly opinionated people. ☹

**Comments invited!** [rap@galaxy.nsc.com](mailto:rap@galaxy.nsc.com) —or: Mail Stop D2597A, National Semiconductor P.O. Box 58090, Santa Clara, CA 95052-8090

**BOB PEASE** obtained a BSEE from MIT in 1961 and is Staff Scientist at National Semiconductor Corp., Santa Clara, California.

**BOB PEASE** | Contributing Editor

rap@galaxy.nsc.com



## What's All This Cold Toes Stuff, Anyhow?

I sure walked into it. I've always known that I can stuff my warm feet (with warm socks) into frozen boots and just start walking, and they would warm up nicely. These are Vasque trekking boots, weighing about 2.1 lb each, well insulated down to about  $-20^{\circ}\text{F}$  and extremely comfortable. So I put them on and hiked up the trail,

all very cozy, on Jan. 17. The air temperature was around  $10^{\circ}\text{F}$  to  $20^{\circ}\text{F}$ —not bad.

But after several hours, I got tired and needed some rest. My metabolism cooled down, my body and limbs cooled down, and my feet cooled down—and they didn't complain. It's like throwing a frog into warm water and adding heat gradually to boil the frog. So my feet got quite cold, and I neglected to dive into my bivouac sack.

Four toes got frozen badly, and six just frosted. But the next day, I walked three miles down the hill, very comfortably. After I came off the hill, I took a shower in my motel room, and my feet didn't hurt. I washed them, dried them, and didn't even look at them, as they didn't hurt, and I had no clue they had been damaged. Four days later, I looked at my toes, and I figured it out. They looked lousy, and I went to a podiatrist. I'll save 92% of my toes.

I've learned that I can't trust my nerves to tell me that my feet are cold. Dr. Bolognini calls this "neuropathy." People with diabetes have to watch out for this. I learned the hard way.

**SENSORS TO THE RESCUE** ¶ How can I go trekking or hiking again next year after I get my feet repaired without fear of chilling my toes? I suddenly began planning (at midnight in my bed) some sensors to keep an eye on my feet and toes.

I could go visit my Friendly Neighborhood Applications Engineer for Temp Sensors. And who is that? R.A. Pease, plus Emmy Denton. So I'm going to write down my plans, show them to Emmy for a sanity check, and build up some toe temp sensors. I don't think it's going to be that hard.

Should I use the LM35Z, or the LM45M, or the LM62M? I'll debate this—any of them would work well. But I'll bring three thin wires up my leg (secured using paper tape) and right past my tummy to plug in to a control panel on my chest, hooked on a lanyard around my neck.

When I push a button, I'll supply +5 V to the  $+V_S$  pin of the analog temp sensor, which will indicate how cold my toes are on a tiny



COLD TOE DETECTOR, BLOCK DIAGRAM

analog voltmeter. I can monitor my toe temperatures—and fingers, too, if I want. Will I add an automatic timer to take a reading every 10 minutes? And beep three times if the toes are okay but only once if they're too cold? Oh, probably.

Battery life should be several days. I'll start with four AAA cells, but later I'll probably go to a lithium cell. Sensor weight plus 5 ft of wires should be less than half an ounce, so I'll be able to bring spares.

It will be easy to build this sensor, but I can't very well test it out for a while. (Oh, I can test it on my wife's feet!) Will it work if my boot gets full of cold water? Steam? To be seen. What would I do if my feet are too cold? Add some foot-warmers. Get in my sleeping bag. Take heroic measures, as after your toes have been frostbitten, they are more susceptible to the cold.

The adjacent block diagram shows a simple scheme to apply power to the LM35 sensors, automatically, alternately, every few minutes. Then, the two sensors have their outputs paralleled (the one that's not powered has no effect on the other sensor) and fed to a voltage-controlled oscillator, so we can hear who's cold. The resistor-diode path tells us the power supply is alive. For the complete schematic, see [www.national.com/rap/coldtoes.html](http://www.national.com/rap/coldtoes.html). 📄

**Comments invited!** rap@galaxy.nsc.com —or: Mail Stop D2597A, National Semiconductor P.O. Box 58090, Santa Clara, CA 95052-8090

**BOB PEASE** obtained a BSEE from MIT in 1961 and is Staff Scientist at National Semiconductor Corp., Santa Clara, California.



**BOB PEASE** | Contributing Editor

rap@galaxy.nsc.com

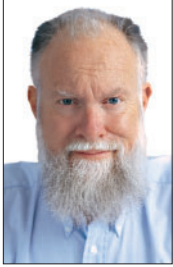

## Bob's Mailbox

**H**ello Bob: I'm designing wideband photodiode amplifiers and using Jerald Graeme's excellent book (*Photodiode Amplifiers—Op Amp Solutions*) as a reference. In the case of a composite transimpedance amplifier (TIA) discussed in Chapter 6, do you know whether the phase compensation requirement that dictates a value of  $C_F$  for stability/gain peaking (i.e., the formula on page 58) changes? (*Refer to my column "What's All This Transimpedance Amplifier Stuff, Anyhow?"* ([www.electronicdesign.com](http://www.electronicdesign.com), ED Online 4346) *Be sure to write down these questions: What BW (min and max) do you need? What noise do you need in that BW? What is your Z source (R, C)? What is the minimum and maximum signal size? Data? These questions can help you define your circuit and amplifier needs. These are usually defined by real circuits and not by a formula. If one circuit doesn't solve your problem, you may need another circuit. No book makes it easy! /rap*) I've designed and built TIAs before, but not high frequency. I'm getting ready to design a photodetector for an analog application to measure pulses (amplitudes) as small as 10  $\mu$ A and as fast as 50-ns pulse width (10-ns rise/fall times). (*If you have signals as fast as that, you are definitely interested in op amps with low V noise, and the I noise probably won't be so important, unless you get silly. You have to get low V noise/(Z<sub>S</sub>) at the high frequency of interest. And you haven't mentioned your C<sub>S</sub>, so I can't guess what your Z<sub>S</sub> is. It had better be a small C<sub>S</sub>... /rap*) Right now I have a spreadsheet (*People who use spreadsheets expect some kind of quasi-linear problem. These TIA problems force you to change your whole circuit, so it's not very linear. /rap*) where the fixed parameters like the op-amp parameters and diode parameters are entered. Then  $R_F$ , damping, and signal current (pulse amplitude) can be played with. What gets calculated is the  $C_F$  (compensation), bandwidth, noise (diode shot, amp current, Johnson, amp voltage, and SNR). The tricky part is the amplifier voltage noise, which experiences noise gain that dominates wideband designs. That is why the datasheet for TI's OPA656 FET amp recommends using the OPA846 (replaced OPA686) and OPA847 (replaced OPA687) bipolar amps, which have lower voltage noise and input capacitance. Besides the TIA topology, I entered in the composite topology and bootstrap but didn't see a real advantage to those. The composite reduces noise bandwidth (and signal bandwidth) with a second op amp in the loop with the TIA, so it probably has some advantages over a separate filter after the TIA. (*I have never been enthusiastic about that approach—not a winner. /rap*) The bootstrap just made the pole from the compensation capacitance (which is a sum of a few capacitances) dominate versus the second-order pole from the limited open-loop gain and feedback zero. This second-order pole is the bandwidth given by the standard TIA bandwidth formula with 45° of phase margin. But if the  $R_F$ ,  $C_F$  pole is less than that, it dominates, and bandwidth corresponds to  $1/(2\pi R_F C_F)$ .

• **John Dailling**

• **Pease:** *Let me know if you have a problem. Sometimes, some foolish person sets you a task that cannot be accomplished. Then you need a friend to explain "this has become impossible..."*

**Hi Bob:** When I read your March 1 column (*"What's All This 'Others Stay Lighted' Stuff, Anyhow?"* p. 20), I had to e-mail you about phasing generators to the grid. With all the wind generators being installed at remote locations, phasing would be a large problem, except wind generators use induction generators. An induction generator is just a three-phase motor (or single-phase motor) that is run above synchronous rpm. Since an induction generator has to run 5% to 8% above synchronous rpm, there is no phasing needed. Just get it close to synchronous rpm and connect to the grid. If the wind generator rpm is low, it will act as a motor and bring it up to speed or load it down to the correct rpm. No phasing or governor is needed. At high wind speeds, the blades stall so the generator does not over-rev. At low wind speeds, the generator becomes a motor and keeps the speed up.

• **Steven Schmitt**

• **Pease:** *You're saying that if an induction generator's synchronous speed is 120 rpm (for example) and you bring the generator up to 119 or 122 and throw the switch to connect it 20 times, there will never be a huge surge of current? Not enough to blow breakers? Many big wind generators now use electronic switching for best efficiency at all rotor and wind speeds. So, any such system would have its own needs for synchronization. Your simplified version probably wouldn't apply. Fair enough? Your statement might apply to small, simple wind systems.*

**Dear Bob:** Your recent article about polypropylene caps (*What's All This Capacitor Leakage Stuff, Anyhow?"* March 29, p. 20) raises a question I've had for a while about Y5V dielectric ceramic caps. I got burned a few years ago on a design where I wanted high capacitance in a low volume and used these near their maximum operating voltage. At that voltage, they only have 10% of their rated capacitance. So what's the use of these things?

• **Mike Partridge**

• **Pease:** *At low voltages and at room temp, i.e., cheap consumer stuff. They are pretty lousy, but the world has a lot of applications for a lousy cap. So these do sell some. ☺*

**Comments invited!** [rap@galaxy.nsc.com](mailto:rap@galaxy.nsc.com) —or:  
Mail Stop D2597A, National Semiconductor  
P.O. Box 58090, Santa Clara, CA 95052-8090

**BOB PEASE** obtained a BSEE from MIT in 1961 and is Staff Scientist at National Semiconductor Corp., Santa Clara, California.

**BOB PEASE** | Contributing Editor

rap@galaxy.nsc.com



## What's All This Dream Stuff, Anyhow?

It's 3:50 a.m. And as I've said before, if I can't get back to sleep after lying there helplessly for 45 minutes, I might as well get up. In this case, I had a dream that was even worth typing. I have about two Safeway bags full of handwritten dreams, plus 120 files of dreams typed. Here's the good, wild dream I had recently.

I was starting down a dark, twisty road after midnight. A fast car was just ahead of me, and I drove fast to catch up with it. (I actually do this, occasionally.) I had some kind of computer screen that showed curves here and there and then blank spaces between curves. (I don't have one of these.) What kind of cars? Undefined—it was dark.

After a while, I sorta caught up with the guy, who let me pass and hollered, "Great road!" And I hollered "Yeah!" I kept driving fast, and after 10 minutes, I got a little ahead of him. I looked out across the dark valley. I couldn't see if it was 10 miles long or 40.

After a while I stopped driving, went in a house, and looked out a big picture window—8 feet high by 30 feet wide. I could see it was only a few miles of valley, but I couldn't see if it was farming or ranching. Not many lights. Dark night.

I descended to the right-hand corner of the picture window in the dark and flipped the catch, slid the window open, and climbed out to a lower level. (I never do this in the real world.) The guy who had been in the following car followed me down through the room and window in the dark.

I walked stealthily through the second living room and opened the second big sliding window. And again, and again, for about eight windows. Then at the last one, I quit.

In the morning, I looked out to see a very big dam, right beside us. It dropped off over 120 feet and was over 500 feet wide, and there was a lot of blue water going over it. The other guy was sleeping in the passenger seat of a car beside the water. A couple of talkative women came over in kayaks and tried to chat him up. He said nothing. He motioned with his finger, "keep quiet," and I said nothing and kept my head down.

After a while, I drove up through town. It seemed to be a small Colorado town at the foot of a big (dammed) lake. I drove through town a couple times. I saw a sign that said "Witch .... Cup." The second time, I came to a slow intersection where long trucks were waiting to turn left. I wedged in on their left and made a left turn. Then I could read the sign—"Witches' Brew Cup." What the heck is that supposed to mean?

I came down to the foot of the town and saw a huge sailboat with a wide extruded "mast" 100 feet tall. At the top and the bottom were rollers, to roll up the "sails," which unrolled like Venetian blinds. I understood immediately that there was a big cup, race, and regatta (sponsored by this local "Witches' Brew") with 10 identical boats. Coming up soon.

As I approached the bottom of town, I looked up at this sailboat on the left and prepared to turn right. I used a fancy flat "mouse" to steer the car to the right. Soon I saw a nice little visitors plaza with many signs that read "Witches' Brew Cup" and "Free Road Map." I pulled in to find out where I was. Of course, as soon as I opened the map, I woke up. (I still wonder where I was!)

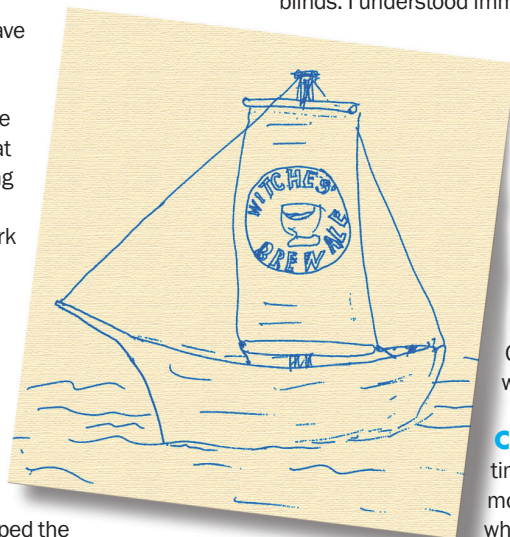

**COLORFUL HEADLIGHTS** • I sometimes dream in color, 2% of the time, but most of this dream was sorta black and white. Even the "blue" water didn't really have much color. It was just dark. Color at

night is minimal in my dreams, though I once saw cars with red, blue, and green headlights on a highway. When they went behind a telephone pole, the color changed!

What's it all mean? Not much, I don't think, but I write them down anyhow. Just yesterday I dreamed I was trying to get advice from three people to find Helen Senk's house, and they were all wrong. The previous night I was buying a hazmat suit with a big zipper, and once inside, I wrote a check for \$85.

And what was the earworm of the night? As I said back in '99, "earworms" are songs that often worm their way into your head and can't get out. Tonight, Miss Peggy Lee's "Willow, Weep For Me" is such a pleasant song. 🎵

**Comments invited!** rap@galaxy.nsc.com —or: Mail Stop D2597A, National Semiconductor P.O. Box 58090, Santa Clara, CA 95052-8090

**BOB PEASE** obtained a BSEE from MIT in 1961 and is Staff Scientist at National Semiconductor Corp., Santa Clara, California.

**BOB PEASE** | Contributing Editor

rap@galaxy.nsc.com



## Bob's Mailbox

**H**i Bob: Just read Bob's Mailbox from the April 12 issue with great interest—in particular, the letter from Terry Hosking about audio capacitors and your reply. It seems to me that the audio field above all others is one beset by pseudoscience and pure wooly thinking. *(I tend to agree. /rap)* As someone who earns his living as an electronics engineer, but also was a classically trained musician in the dim and distant past, I am very much aware of just how subjective any judgement of audio “quality” is likely to be. In particular, I cringe inwardly when I read or hear audiophiles raving over this amplifier's total harmonic distortion (THD) figure being 0.001% lower than that amplifier's figure. It may well be, when measured under certain conditions. But—and this is a big but—in a completely blind test, would anyone be able to consistently judge one as better than the other? I somehow doubt it. *(I have actually seen cases where distortion as small as that can be heard and appreciated. If you look at the LM4702 data sheet, there is a basic audio amplifier, where the negative input of the LM4702 is coupled to ground through 20  $\mu$ F and 1.8k. If you put 200  $\mu$ F across the 20  $\mu$ F, it sounds a lot better because electrolytics can generate distortion. Now, I measured the distortion at 20 Hz caused by the electrolytic, and it's about 2 ppm. Yet I have heard people with good ears say that the music sounds (slightly) noticeably better if the 200  $\mu$ F is bypassed with a wire shunt. (Also, I want to do some tests with 2000  $\mu$ F, but everybody's too busy to listen.) I am sure the distortion they hear is not the 2 ppm of distortion I measured, so it must be something else. But still, it is probably very small. The LM4702 has a THD of about 3 ppm at its output. Some people say it sounds as good as any power amplifier they have ever heard. That may well be so. It sure is clean with low distortion, with a clean transient response. /rap)* What I would be interested to know, and maybe you or your readership may be able to help with it, is whether any such tests have ever been carried out in proper, controlled circumstances. And if so, what were the results?

- **Chris Hill**
- **Pease:** *I have tried to set up some controlled A-B tests, but most people seem to be too busy to do such tests. Thanks for the comments.*

**Hi Bob:** Can you suggest any reasonably comprehensive sources of information on the analog characteristics of “passive” components—for example, the dielectric absorption of surface-mount capacitors? I recently ran into a problem where a supplier of assembled printed-circuit boards (PCBs) substituted a polyester cap for an obsolete polycarbonate in an integrator circuit. Changing the PCB layout was not an option, so the cap was predefined as 0.1  $\mu$ F in a 1218 package. The available parts were Mylar (polyester—cheap but bad), PEN (polyethylene

naphthalate—better), and PPS (polyphenylene sulfide—good enough). *(My experience is consistent with yours. PPS is the least bad of all the ones you mentioned, as wave-solderable. The polypropylenes are much better, but not so small, and not wave-solderable. /rap)* My setup was cheap and dirty:  $\pm 5$ -V power supply/single-pole double-throw (SPDT), center off switch/1k resistor/cap under test/LPC661 buffer/DMM. The procedure was to switch the device under test to +5 for 1 minute, to 0 for 1 second, then open, and watch the DMM. *(That is basically the right test, but you might need to change the times if you were using the cap in a different timeframe. /rap)* I also learned that all of the surface-mount film caps that I tested were useless after reflow soldering, unless they were immediately and properly cleaned with hot DI water.

- **Ben Barnett**
- **Pease:** *Huh. I guess I didn't know that.*

**Bob:** I assume from your comments in “What's All This Cold Toes Stuff, Anyhow?” (April 27, p. 20) that you have diabetes. *(Correct. /rap)* If so, you might want to think about changing doctors. Peripheral neuropathy is indeed a common complication of diabetes, common enough that all diabetics should be warned about it and what consequences it might have, even if they don't yet have it. *(I guess I should ask for a good contact for a diabetes specialist. Since I was diagnosed with diabetes, I have hiked for more than 12 years, and in cold weather, and in insane conditions, for thousands of miles and never had any trouble until January. /rap)* Furthermore, it's possible (even easy) to test for peripheral neuropathy during a regular checkup. This should be done, and any patient who develops signs of peripheral neuropathy should be warned again, more specifically. *(Uh, yeah! I will check into this. Note: hiking hard and burning off the sugar (and taking in extra sugar) has given me some of the best health of my life. So I have still done a lot of things right. /rap)* What happened to you shouldn't have happened, unless you were warned and ignored those warnings.

- **Fred Webb**
- **Pease:** *I was not warned. But what happened to me was a gradual deal. How the hell do you give a frog a warning about warmer and warmer water? Just today, the pain went out of my left foot. Don't ask me to explain it. The right foot lost the pains a week ago. So while I am still angry at myself, and only myself, I am not as mad as I was. Thanks for the advice. 🙏*

**Comments invited!** rap@galaxy.nsc.com —or:  
Mail Stop D2597A, National Semiconductor  
P.O. Box 58090, Santa Clara, CA 95052-8090

**BOB PEASE** obtained a BSEE from MIT in 1961 and is Staff Scientist at National Semiconductor Corp., Santa Clara, California.



## What's All This $V_{BE}$ Stuff, Anyhow? (Part 2)

I've been debating with a guy who argues that a transistor won't work as a transistor unless its  $V_{CE}$  is bigger than its  $V_{BE}$ . He keeps reading this in books. Also, he points out that if the base and collector are nominally tied together to make a diode, you might think that it's okay. But actually, he says, the  $I \times R$  in the collector path makes the

$V_{CE}$  lower than the base voltage, so it won't work. Well, I've been looking in some of those books, and they sometimes do say that. But when they do, they're wrong.

When a transistor's  $V_{CE}$  is slightly less than its  $V_{BE}$ , it keeps right on working like a transistor. Can I prove this? Sure. Look in the NSC linear Databook at circuits such as the LM10. The LM10 wouldn't work on a 1.1-V power supply, if the transistors aren't working well with  $V_{CE}$  as low as

350 or 250 or even 150 mV, which is far below  $V_{BE}$ . Of course, you have to be a good engineer to make these circuits work well.

NSC guys (like Bob Widlar) have been doing this for 40 years. Look at the  $V_{CE}$  curves of any transistor. When  $V_{CE}$  falls below  $V_{BE}$ , it's not a disaster. Put a transistor on a curve-tracer. Apply a bias like 1  $\mu$ A per step to the base. When you change the  $V_{CE}$  from +1.0 V to 0.6 V to 0.5 or 0.4 V,  $I_C$  doesn't change much, does it?

Okay, maybe when you get  $V_{CE}$  down to 0.35 V, the gain starts to degrade some. But above that, at room temperature, it's not a big deal. There is no demarcation between  $V_{CE} > V_{BE}$  and  $V_{CE} < V_{BE}$ . No inflection. The beta doesn't even change more than perhaps 2% per volt, and it does so smoothly.

Now run the temperature up to 125°C. Can you design a circuit that works up there? It's not easy. But if you don't need a lot of swing, some specialized circuits work just fine. Look at the LM4041-1.2 or the LM185. Many of their  $V_{CE}$ s are about 0.3 V, yet they work hot and cold.

How about 160°C? How about 260°C? I can't, but Widlar could, and did, in the LM12. After all, in the old days, a pentode could run with a very low  $V_{PLATE}$ —much lower than  $V_{SCREEN}$ . It's hard to comprehend this, but after a while, you get to understand and believe it. It's an analogous situation that the output voltage is so low, you can't believe it will work. But it's true. It does work.

**NEXT TOPIC** • When  $V_{BE}$  = approximately zero, changes in  $V_{BE}$  certainly have no effect on  $I_C$ , right? Wrong. In Widlar's LM12, some of the transistors are so biased, when  $V_{BE} = 0$ , the  $V_{BE}$  can still influence the collector current (and vice versa) whether the  $V_{BE}$  is a few millivolts positive or negative.



The upper curve represents a 2N3904 biased up with  $I_B = 7 \mu$ A,  $V_{BE} = 700$  mV, and  $I_C = 1.05$  mA. As  $V_{CE}$  decreases from 0.7 V (at the right-hand arrow) to  $V_{CE} = 0.25$  V (at the left-hand arrow), this transistor obviously is acting like a transistor in its active region, even though  $V_{CE}$  is well below  $V_{BE}$ . Of course!

Admittedly, you can't see this easily in a silicon transistor at room temperature. But you can see this in a silicon transistor at 220°C, or in a germanium transistor at room temperature, which is about the same idea. Go ahead and measure it. When I did, I was impressed by Bob Widlar's brilliance.

Also, the beta of a transistor can still be important, even when  $V_{BE}$  is about zero. That's because as  $V_{BE}$  moves up and down a few millivolts

compared to zero, the base current needed may be small, but finite—not negligible. The base current and its changes are necessary. And if you start at  $I_B = 0$  and pull the base negative, the collector current can decrease.

I must remind you that high-beta transistors (300 and up) still have disadvantages in terms of voltage gain or  $\mu$ . When the beta gets too high, and because  $\mu$  is inversely proportional to beta, the voltage gain is hurt. I remember a test that asked how much voltage gain a particular amplifier design has. The answer was supposed to be 20,000. But the gain was really 9000, as the betas were too high and the Early Effect was too strong. I passed the test after I explained my solution.

As a rule of thumb, I use  $\mu \times \text{beta} = 2$  million. On some devices, that product is only as good as 1 million, or even 4 million on LM194. If the beta gets better, the  $\mu = 1/h_{RB}$  gets worse, and the voltage gain suffers. Be careful not to allow in transistors with too high beta in circuits where poor  $\mu$  could cause poor performance. Beta is often important. Too much of it can do harm. So can too little. ☹

Part one appeared in *Electronic Design's* Analog Applications Supplement, June 26, 2000. Go to [www.national.com/rap/Story/vbe.html](http://www.national.com/rap/Story/vbe.html).

**Comments invited!** [rap@galaxy.nsc.com](mailto:rap@galaxy.nsc.com) —or: Mail Stop D2597A, National Semiconductor P.O. Box 58090, Santa Clara, CA 95052-8090

**BOB PEASE** obtained a BSEE from MIT in 1961 and is Staff Scientist at National Semiconductor Corp., Santa Clara, California.

**BOB PEASE** | Contributing Editor

rap@galaxy.nsc.com

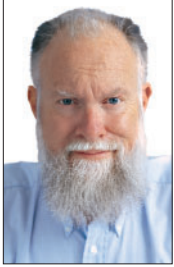

## Bob's Mailbox

**B**ob: An induction motor pulls nameplate current at nameplate rpm. If it is being used as a generator, the slip is opposite what is experienced when the device is used as a motor, but rated power is produced at about the same absolute slip. If connection is made between the mains and motor/generator at any speed between rated motor full-load rpm and synchronous speed plus rated slip, the current must be equal to or less than nameplate current. The service factor rating even provides a little additional slack for speed matching. There will be no huge surge of current. There may be issues with the control system if it comes up in the wrong quadrant, or the gear box may not like the torque reversal under the same conditions. A motor used for this service should certainly be as efficient as can be afforded (*But that is always true—a tautology. /rap*) and that feature will decrease the full-load slip. Engagement at near synchronous speed is pretty easy for an induction machine. I often start the engines of small induction generators from a dead stop by plugging the contactor to turn the engine over. Sometimes the engines do not even have starters installed. (*Check. I often start my Beetle by popping the clutch at a low speed (6 mph in second or 10 mph in third). I've been told this does less harm/damage/cost than turning the key and exercising the Bendix. I tend to believe it. But I have only replaced a Bendix once in 45 years/1,500,000 miles. /rap*) Remember that induction motors are often started across the line while attached to full load. Lucky motors get reduced voltage, partial winding, soft-start, or Y delta starters. Most oil-well-pumping units and gravel crushers just get oversize magnetic contactors. Starting current is limited by long lines or the service transformers. (*My father had a circular table saw, and I remember when it started properly by turning on its switch. But when it refused to start (bad cap or bad winding?), he just blocked up the motor, spun the pulley, hit the switch, and lowered the motor down against its pulleys after it started—not a big deal! Just a normal trick! I've learned how to do it. /rap*) The control system in most wind turbines is far less sophisticated than you would expect. (*I have been told that some have synchronous converters—what, 2%, 4%, 8%, 16%? /rap*) Those guys have come a long way, but they have a long way to go. Don't give them undeserved credit, and don't give them my address. Sorry to hear about the frostbite.

• **John Carroll**

• **Pease:** Not a big deal. I'm gaining on it.

**Hi Bob:** I just read Bob's Mailbox from June 7, and I must make a point about total harmonic distortion (THD) in audio systems that many people miss. What really matters are which harmonics and non-harmonically related overtones are generated during distortion. For example, crossover distortion (caused by an underbiased class AB amp) is much more objectionable than clipping. That is to say that if the distortion is caused only by

clipping, a higher percentage of THD is permissible than if the distortion is caused by underbiasing. (*We agree, of course, that some kinds of distortion are more important than others. But when the distortion gets down to 3 or 1 ppm (not to mention 0.3 ppm), I don't think the distortion is important anymore. Take a look at the datasheets on the LM4562 and LM4702. /rap*) One attempt to weight the harmonics to make a distortion measurement scheme that reflects subjective evaluation is the GedLee metric ([www.gedlee.com/distortion\\_perception.htm](http://www.gedlee.com/distortion_perception.htm)). From what I understand, it correlates very well with subjective ratings.

• **Stephen L. Martin**

• **Pease:** Thanks. Best regards.

**Hi Bob:** I just got back from a 500-mile hiking trip on the Appalachian Trail and saw your piece on the cold-toe detector (*"What's All This Cold Toes Stuff, Anyhow?" April 27, p. 20*). I would think this would be an ideal application for a small micro-power microprocessor. (*No, it would not be "ideal," because I do not do microprocessors. I do human interface. /rap*) Using one of these, the parts count would be reduced to four: the temperature sensor (*My scheme can accommodate four or more temperature sensors. /rap*), processor, signaling device, and small button cell for power. It could be made small enough to mount on the shoe, say, where the tongue of the boot starts. (*When the tongue of the boot is covered with a foot of snow, I'm not going to peek to see if the LED is blinking. I want it to beep in my ear. Besides, my boot is usually covered up with leggings. /rap*) (I'm not too keen on the idea of running wires up my legs!) A piezo speaker or flashing LED could warn you the temperature at the toes is below freezing. (*No way! I want to know when the temperature is dropping! Your mentality that a computer can tell me that my feet are already too cold is exactly what's wrong with all the digital guys. Sorry, but go away. Get thee behind me, Satan! /rap*) The advantage of this approach is the processor can be programmed to take a temperature reading at given intervals and then to take readings at shorter intervals if the temperature approaches a dangerous level. When not active, the circuit would draw microamps, making a small button cell practical. The only downside of this approach is the need to write a simple program and programming the processor with it.

• **Steve Weber**

• **Pease:** I've never made any mistakes writing software. Because I never write software. And I'm not going to start now. ☹️

**Comments invited!** [rap@galaxy.nsc.com](mailto:rap@galaxy.nsc.com) —or:  
Mail Stop D2597A, National Semiconductor  
P.O. Box 58090, Santa Clara, CA 95052-8090

**BOB PEASE** obtained a BSEE from MIT in 1961 and is Staff Scientist at National Semiconductor Corp., Santa Clara, California.

**BOB PEASE** | Contributing Editor

rap@galaxy.nsc.com



## What's All This Production Costs Stuff, Anyhow?

A guy asked me how to optimize a bridge circuit. His design had eight op amps and over a dozen precision resistors. I showed him how to minimize the number of (expensive) resistors and precision op amps. I got it down from eight to four to two. Then I even figured how to get the number of op amps down to one.

But before we finished, I had to inquire how many bridge circuits he was planning to make. That's important. If you're only going to make five or 10 or 20 of them, you will probably want to just get the circuit built and running and evaluate the system you are going to run. The cost per unit is not important. The time you waste optimizing it could be very important.

If you're planning to make thousands of them, you'll want to put in some extra engineering effort to figure out how to optimize and minimize the cost of each component—which usually isn't important if you're going to build only a few. The cost of parts, the assembly labor, and the trim-and-test work will be quite important for a large-volume design.

So when a guy asks for help, I have to explain this problem. Do engineers understand this? The good, experienced ones do. The new ones (the ones who have to ask a lot of questions) have to learn. Often, trying to be very frugal and using the cheapest parts is poor economy. Spending more for some precision parts may save you a lot of grief.

It's very much the same as a guy asking, "How can I get the best low-noise amplifier?" As I always respond, "What's the bandwidth, what's the source impedance, and what's the size of the smallest and largest signals?" Without that information, you can't optimize anything. So the planning is really important.

**PLAY BY THE RULES—IF YOU KNOW THEM** • When I was back at Philbrick, we had several plans for optimizing a potted module. One plan was to optimize parts cost plus 150% of assembly labor at 2 cents per second. Back in 1970. But one day, I was told my new circuit was badly designed because I was violating the new rules. "What new rules?" I asked.

They forgot to tell me that they had changed the rules. It was now 150% of parts plus 450% of labor and assembly costs—and they hadn't bothered to tell me the rules had changed. The word infuriated isn't strong enough to describe my mood. How the heck am I supposed to do my job with poor information?

Another time, they changed the "rules" so that the cost of a jumper went up (or down), while the cost of a double-sided pc board went down (or up). But they didn't tell the engineers. So I confronted our manager, Richard. "These new rules mean I



should avoid a double-sided pc board and put in a few jumper wires, right?" After he thought about it a second, he saw red, and said, "No, that would be wrong. Let me get that fixed."

Well, in a couple of weeks, Richard was gone, and the question wasn't solved. And a month later, I was gone. I walked out on the last day of 1976. If you're hired to optimize new designs, but the rules keep changing—and they forget to tell you the rules—hey, you have to walk out.

**PLAY BY THE RULES, PART 2** • My friend Arnold had designed a very good high-voltage amplifier with  $\pm 100$ -V output swing, the Teledyne Philbrick 1022. But the guys in marketing decided they needed a low-price version to fill a high-volume need.

So Arnie took all the rules and figured out how to use a more spacious layout (so things weren't packed in so tight) with lower assembly costs and lower-cost parts to make the Model 1032, with definite cost improvements.

But after it was put into production, the Manufacturing Department decided to re-interpret the rules, and the Model 1032 was listed as more expensive than the 1022. Arnie couldn't win. He bailed out, too.

**BOOK REVIEW** • Check out *Wideband Amplifiers* by Peter Starič and Erik Margan. Available from Springer.com for about \$159, this 612-page book covers all aspects of high-frequency amplifier design. It is now in its second edition after correcting a few typo errors. The first printing sold out. I like its attitude and its insights. It covers theoretical and practical applications, computer-aided design and filters, real semiconductors, and integrated circuits. It also covers bipolar transistors, FETs, fast op amps, and current-feedback amplifiers. I'll recommend it for anybody working in this field. 📖

**Comments invited!** rap@galaxy.nsc.com —or: Mail Stop D2597A, National Semiconductor P.O. Box 58090, Santa Clara, CA 95052-8090

**BOB PEASE** obtained a BSEE from MIT in 1961 and is Staff Scientist at National Semiconductor Corp., Santa Clara, California.

**BOB PEASE** | Contributing Editor

rap@galaxy.nsc.com

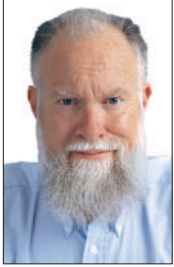

## Bob's Mailbox

**B**ob: Several years ago, an acquaintance bought a very expensive “high-end” audio system. The speakers were huge. The amplifiers were 350-W “mono blocks” using eight 6550s in a push-pull parallel configuration. The wires were about \$100 per foot. Within a minute of first operating the system, the amplifiers were releasing smoke. He called the amplifier manufacturer. Their first question was “What cable are you using?” The strange impedance of the fancy cables interacted with the feedback system in the amplifier and caused an ultrasonic oscillation that destroyed them. So maybe the cable makes a difference, not because of its characteristics but its action on the amplifier and speakers. Not many amplifiers have a truly zero output impedance, especially vacuum-tube types.

- **Bob Bodmer**
- **Pease:** *I have heard people say that low-impedance speaker cables have a lot of capacitance per unit length, if you just measure the cable open-circuit. “So when you run an amplifier that doesn’t like capacitive loads, it can oscillate and cause great damage,” these people say. First of all, vacuum tubes are supposed to be able to tolerate overloads in any good design. Second of all, a low-impedance speaker cable does not look like a capacitor unless you run it with no speaker. My favorite speaker cable is to parallel 20 strands of wire, going out to the speaker, and each wire serves as a twisted pair with one of the 20 (paralleled) return wires that come back to ground. If you run this with no 8-Ω speaker, it will indeed act capacitive, and the amplifier might be unhappy driving the many thousands of pf. It will look like an unterminated transmission line, and the reflections could be nasty. But when connected to an 8-Ω speaker, it looks like 7.5 Ω because it has the characteristics of a 7-Ω transmission line. So every amplifier should drive this cheerfully. The cable and load will act like 7 or 8 Ω at all frequencies, unlike lamp cord that acts like an 80-Ω transmission line at high frequencies. Audio amplifiers are not required to have a 0-Ω output impedance. Any low impedance that is consistent and predictable can work just fine. An audio amplifier that wouldn’t drive an 8-Ω load sounds pretty flaky. And if a customer complains and the amplifier maker tells him “Oh, we forgot to tell you, our amplifiers don’t like certain kinds of loads,” but they didn’t put it in their user’s manual, that is a poor way to do business.*

**Bob:** I saw your comments about Y5V dielectric in the May 10 issue. I have always avoided it, not only for its –80% voltage coefficient but also its poor temperature coefficient. For general-purpose use with 20% tolerance, I have always specified X7R dielectric or its more recent derivative X5R. However, recent cost-saving process technology changes mean you have to be wary. Time was

when X7R capacitance was –20% at rated voltage. Now with modern thin-layer printing technology, the change of capacitance is –50%. So be careful. If your design needs 20% tolerance, you need to double the rated voltage of the X7R capacitors you use. For a 5-V supply, use a 10-V part, not 6.3 V. It is better to do this than to double the capacitance. The cost is about the same, and so is the capacitance at working voltage. But the reduced coefficient of the higher-voltage part makes for a more stable design.

- **Chris Green**
- **Pease:** *Yeah, I believe it. Many “improved” processes are worse than ever. Your solution seems reasonable.*

**Dear Bob:** I just wanted to write you a quick note commending you on your “What’s All This Capacitor Leakage Stuff, Anyhow?” article (March 29, 2007). From the title I suspected that the devil of the measurement would be in the (attention to) details, and it was! When I read the sentence “I also keep my left hand grounded to +8.8 V,” I was thoroughly pleased! You think like an electron, and that is a good thing.

- **Chuck Woringer**
- **Pease:** *I tried grounding my left hand to +1 V. It made tiny errors, but when I did it nine times in a row, it made very small errors, and I didn’t even want to make tiny errors. I thought about finding a teflon-insulated ball-hook or teflon-insulated alligator clip, and that ain’t easy. By “grounding” my left hand to +8.8 V, the problem shrank to an acceptable error.*

**Dear Mr. Pease:** One of your columns (Jan. 18, 2007) commented that it will be a long time before you will change to SI units. You are in good company. A few months ago, I was curious about the pace of conversion to SI. I noticed an important organization that tried metric units, and now it changed back to U.S. Customary units. The document is called “Caltrans Metric to U.S. Customary Units Transition Plan” ([www.dot.ca.gov/hq/oppd/metric/TransitionPlan/Transition-Plan-021105.pdf](http://www.dot.ca.gov/hq/oppd/metric/TransitionPlan/Transition-Plan-021105.pdf)).

- **Jim Marks**
- **Pease:** *Yeah, I peeked at that 29-page document, and sent it to print out, and will read it later. The introduction says it will be less trouble to go back to “all U.S. units” and less likely to lead to the delays or extra expenses that happened in metric conversion—and safer, as of the era 2005-2007. Maybe we should share this philosophy with the Brits and Aussies.* ☺

**Comments invited!** [rap@galaxy.nsc.com](mailto:rap@galaxy.nsc.com) —or:  
Mail Stop D2597A, National Semiconductor  
P.O. Box 58090, Santa Clara, CA 95052-8090

**BOB PEASE** obtained a BSEE from MIT in 1961 and is Staff Scientist at National Semiconductor Corp., Santa Clara, California.

**BOB PEASE** | Contributing Editor

rap@galaxy.nsc.com



## What's All This Canyon Turn Stuff, Anyhow?

Let's say you're flying a light plane, and you fly up into a canyon at 8000 feet. At 8000 feet, your turning radius is perhaps 600 feet. The canyon is 1000 feet wide. You'd like to turn and get out of the canyon, but there's no room to turn. And the canyon floor is rising too fast for you to climb out. Are you dead?

Maybe not. I have been studying this for several years. Our good friends lost their daughter in a flying accident in a box canyon, just like that, about 10 years ago. She and another student pilot died in the crash, along with the certified flight instructor. I still cry about that. A lot. Especially today. How can you get out of this trap?

(a) Put down your flaps to 10° or 15° (or maybe 20°) to increase lift and drag. Apply full throttle. Do not let speed build up. Do not let your altitude above the canyon floor get small. Turning radius may be 600 feet at full speed, but it may be smaller under those conditions. You can turn a lot better. Flaps and power help you maintain control and avoid stalling. Maintaining some altitude above the ground can be extremely important in view of (c).

(b) Get way over to the right of the canyon, maybe 40 feet from the wall. I say to the right, because the flight instructor (or pilot in charge) on the left should be in charge of these fairly dangerous maneuvers. He has to use his best judgement. His feel for what the plane is doing is very important.

When he cocks the ailerons and pulls back on the yoke, it may be very close to a stall. You gotta have a feel for that. It's also true that the engine's torque may help you turn left better than right. (If the canyon is deepest on the right, okay, get over to the left. Or if you know there is a crosswind from the right, turn toward it.)

(c) Make your turn early, make a hard turn, and let the plane descend. Use the plane's lift to pull you around in the tightest possible safe turn that you can do without stalling. If you tried to hold altitude, you will probably stall and crash. But if you let the plane descend to the left, you have a better chance. That's assuming you are somewhat above the canyon floor.

(d) Do not fly up into canyons. Never. If you want to check out a canyon, always come in from above and descend—assuming the canyon does not have excessive sharp turns or narrows (of which there may be many).

(e) Under conditions of full power but lowered flaps, you may be flying at 55 or 45 mph depending on the headwinds. So even if planes aren't exactly as bust-proof as cars, you have some chances of surviving a 50-mph crash. Not so at 85 mph.

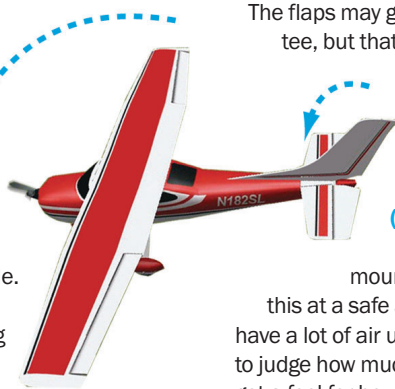

The flaps may get you around the corner. There's no guarantee, but that's what I would bet on. Better odds—and a better chance for a good pilot's skill to help. Of course, a really good pilot would never get you in that bind in the first place. A cat will not crawl into a hole where his whiskers scratch the walls.

(f) If you live in flat country, you may never have to worry about this. But if you live near mountains, you would definitely want to practice

this at a safe altitude, out in the open, so if you stall, you have a lot of air under you to recover. You may not be able to judge how much space this maneuver takes, but you can get a feel for how the plane feels and handles.

(g) If you were in a very narrow canyon, maybe 200 feet wide, you could zoom up, cut speed, apply some flaps, do a half-roll, cut power way back, and finish your half-loop. But this is not legal for most light planes, and it might cause excessive G's or speed. It still might save your life—if you were 600 feet or more above the canyon floor.

**MOUNTAIN PASSES** • Do not fly directly toward a high mountain pass trying to get across. If you have a large altitude margin, you might do that. But if you aren't sure, don't try to fly toward the pass.

Circle around on the right. If your altitude is okay, then you could fly up to the pass and go ahead and veer right across the pass. But if you are kind of skeptical, and you think there may be downdrafts, or if you aren't sure there will be enough updraft, veer left and go around again. Try to get a little higher and burn off a couple gallons. You may have much better luck on the next try.

Too many pilots have failed and crashed because they were confident they could get over a pass. But downdrafts can be very nasty and can be the downfall of "confident" pilots. The Alaskan bush pilots who are alive today have learned from such advice. ☹

**Comments invited!** rap@galaxy.nsc.com —or: Mail Stop D2597A, National Semiconductor P.O. Box 58090, Santa Clara, CA 95052-8090

**BOB PEASE** obtained a BSEE from MIT in 1961 and is Staff Scientist at National Semiconductor Corp., Santa Clara, California.





**BOB PEASE** | Contributing Editor  
rap@galaxynsc.com



# What's All This God Stuff, Anyhow?

There's an old story about an American visiting Ireland. As he was imbibing a beer at a tavern, one of the locals asked him, "Now, are ye a Catholic or a Protestant?" The American replied astutely, "Neither. I'm an atheist." Then the canny Irishman asked sharply, "Ah, but are you a Catholic atheist or a Protestant atheist?"

These days, trying to prove whether you're a Sunni atheist or a Shiite atheist in Iraq doesn't sound very easy, either. Yet it might be important, depending on who's asking the question.

I am not going to argue with you about your religion, or any version thereof, or any lack thereof. Whatever you like to believe in is fine with me. As near as I can tell, there is a very wide distribution of religious belief within the engineering and scientific community. Also fine by me. I've heard some people argue that if you believe in evolution, you can't believe in a religion—and vice versa. I don't agree with that correlation at all, and a lot of people don't.

Do I believe in God? Yes. I am a Christian and a member of an Episcopal church. You may have heard that in the 1860s, every Christian church in the U.S. split asunder over the issue of slavery—except for the Episcopalians. Apparently, they thought they could "get along" despite serious differences.

"God has been good to me, Alleluia"  
(do re mi mi mi re, do re re)  
"Let me return the favor, Alleluia"  
(do, re, mi mi, re, do, re, do)

**DO THE RIGHT THING** • I'm not going to argue with people who say they are atheists, or agnostics, or any particular religion. But I am in favor of God. "I will try to help God," and I think God will encourage me to do the right thing.

What is the "right" thing? Everybody has his or her own moral compass. I don't want to argue much about this. Exactly where your moral compass is, or where you got it from, is your business. So long as it works, that's fine with me.

But eventually you might ask yourself where you got your ethics. Did you get them from a church or a Sunday school? Did you get them from your mother or father? Whatever way you got them, thought about them, and refined them is fine by me. Even reading *Dilbert* can bring you to conclude that some of the characters in that comic strip learned their ethics from some strange places. Learning to not do what the pointy-haired boss does is a pretty fair way to learn ethics.

When we ran the 1909 Rutherford experiment in our 1960 physics lab, we learned that bombarding the nucleus of a gold atom could lead to some knowledge of the structure of the nucleus. You bombard a beam of alpha particles off a gold atom's nucleus and see at what angle they bounce back. The distribution is quite educational.

Similarly, when problems are bounced off of us, we don't have to write down how we define our ethics. But eventually, by circumstances, we show what our ethics are.

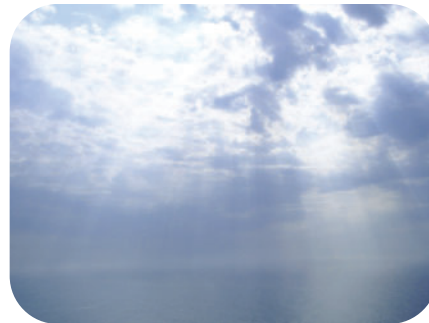

**ON THE JOB** • Here at NSC, we have an intranet course on business ethics that is fairly good. We had to study certain intercompany relationships and figure out how to be fair to our customers. All employees are supposed to take its test until they pass.

It's fairly educational. I don't think Wally could pass it, nor the pointy-haired boss.

Do you believe in (most of) the 10 Commandments? That's good for a lot of real-world cases. How about the Golden Rule? Many of us agree on that—most of the time. How about the IEEE Code of Ethics ([www.ieee.org/portal/pages/about/whatis/code.html](http://www.ieee.org/portal/pages/about/whatis/code.html))? I tried to find help there a couple of times, but didn't find much.

As long as your moral compass works, that's fine with me. Most engineers (and most people) have figured out that being nice and fair to your customer is a good idea. "Screw the customer" has long been recognized as a poor business practice.

So, I won't try to argue with any reader about religion. But I tend to be in favor of religion. And its positive side. I wish we could all avoid its negative side. In many places, Protestants and Catholics have learned to get along. Even in Ireland. "Love your neighbor" is a nice theory, but stopping "hate your neighbor" may be even more important.

What religion (if any) do you believe in? It sure is none of my business. But it would be nice if your religion allowed you the same respect for my beliefs as I have for yours. I don't denigrate your religion. If the U.N. Charter promises freedom of religion, does that allow your religion to denigrate mine? I'd hope not.

P.S.: Access to God is wireless. ☺

**Comments invited!** [rap@galaxy.nsc.com](mailto:rap@galaxy.nsc.com) —or:  
Mail Stop D2597A, National Semiconductor  
P.O. Box 58090, Santa Clara, CA 95052-8090

**BOB PEASE** obtained a BSEE from MIT in 1961 and is Staff Scientist at National Semiconductor Corp., Santa Clara, Calif.

**BOB PEASE** | Contributing Editor

rap@galaxy.nsc.com

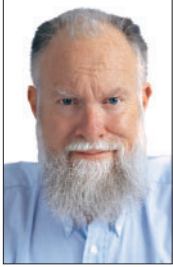

## Bob's Mailbox

Many people wrote in about "What's All This Canyon Turn Stuff, Anyhow?" (Aug. 16, 2007, p. 16.) Some suggested the pilot should do a Chandelle, an Immelman, a Wingover, or a Hammerhead Stall. Tony Schrock suggested [www.scootworks.com/rdrc/aerobat.html](http://www.scootworks.com/rdrc/aerobat.html) for illustrations of these and other maneuvers. But as the plane was fully loaded and underpowered, and the elevation was 8000 ft, and the day was hot, none of those were going to work.

Some people said my 20° flaps setting was about right. Others said that full flaps might even be better. Some guys said, "Line up above a road when you practice this over low country, and see how far offset you are after your turn." One guy suggested using a GPS, and that should work even better.

Everybody agreed that you never want to fly up into a canyon, and even flying down through a canyon could be very dangerous unless you were positive there were no bad kinks. One guy, however, said that my theory that a cat won't crawl into a small hole if its whiskers were scratching the sides was just an old wives' tale. Well, that's what my mother told me, and maybe she was wrong.

Here's a related story.

**Hello Bob:** I read your article on the canyon turn. I too had a good friend perish in a similar event in the Sierras. He was my boss at my first job after high school. I then moved on to become a pilot myself after a short run in the Navy and made a career of it until starting my current company. His memory stays with me to date. I had a similar event while on my long cross-country flight for my commercial license that proves your input here. After a trip to Los Angeles, Vegas, then Reno, I got up the next morning, and guess what... snow! I did my preflight checking, weather at destination, etc. Visibility was visual flight rules, but barely. I decided to load up and give it a run for the pass. I did go to the pilot briefing room and studied a local chart posted on the wall. It had the box canyon to the left of the pass highlighted. My father was an ex-B-17 pilot. I asked him, being on the right side, to watch for the highway to turn to the right, marking the pass exit to turn down, to then follow Highway 50. Yup, he missed it. I had hit my clock to mark time and decided that if he hadn't called it by then, I would head back. Visibility was lowering quickly, to about half a mile in blowing snow. We were heading into the jaws of the storm—and the box canyon. I started my turn and noticed the trees coming into view very quickly. I ran the flaps now to Max L/D (about 22°) and applied full power during the turn. The pine cones were now visible. The stall warning horn was hinting what an idiot I was! I continued the turn (obviously, since I am writing you) and made my way back to the airport. We



**Nicknamed Thunderbird, this B-17G Flying Fortress belongs to the Lone Star Flight Museum, Galveston, Texas. (photo by Master Sgt. Michael A. Kaplan, U.S. Air Force)**

all jumped out with shaking knees and went for a cold one! Stayed a day or so longer and made it home safely. I became a flight instructor and made

it a practice to teach that experience and technique. It works. I used to fly into canyons practicing the maneuver as far as I could go and make a turn (in good weather). Thought I would share it with you. You may save someone's life or lives. Good for you.

- **Michael A.**
- **Pease:** *Yeah, man. It's tough to figure out the navigation in the best conditions, not to mention in snow. I'm glad that heavy flaps and full power got you around the curve.*

**Bob:** Back in World War II, B-17s flying to England from the U.S. had to stop for gas at West Bluie Two, a landing strip in Greenland. Unfortunately, WB2 was many miles up a fjord, and there were three identical fjords in the area. If you went up the wrong fjord, you were in a heap of trouble. The only definite way to recognize the correct one was to fly up one, and if you did not see a sunken ship 2.6 miles up the fjord, you were in the wrong one and had to do an immediate canyon turn. Not easy to do in the fog at the end of a long flight with engines and props configured for maximum range. Those were real men in those days.

- **George Gonzalez**
- **Pease:** *Uh, yeah. But at least the plane was lightly loaded. Was it really that hard for a B-17 with no bomb load to fly from Newfy to Greenland? Maybe it was. And speaking of B-17s again, I saw a B-17 take off from Moffet Field recently, and it was damn impressive. And not very big. Just tough as nails, as were the kids who flew them.*

**FLOATING GAME** • As for the test when an oil can was getting full ("Bob's Mailbox," Sept. 1, 2007, p. 18), several people chided me for using electronics when a simple float would work much better. But none of them were able to convince me that the float wouldn't get jammed or stuck. So, I think one of the electronic solutions might be the winner. 🗑️

**Comments invited!** [rap@galaxy.nsc.com](mailto:rap@galaxy.nsc.com) —or: Mail Stop D2597A, National Semiconductor P.O. Box 58090, Santa Clara, CA 95052-8090

**BOB PEASE** obtained a BSEE from MIT in 1961 and is Staff Scientist at National Semiconductor Corp., Santa Clara, California.



## What's All This Safety Margin Stuff, Anyhow?

Sometimes it's easy to tell if you have a safety margin. With a voltage regulator, or any linear amplifier, if it was oscillating, you could add a fix—often, a simple series R-C network from the input or output to ground. Good. But is it good enough?

To be safe, you should put in a square wave of voltage (or pull out a square wave of current through a little R-C network) and make sure that there isn't any bad ringing. Now, to be quite sure, you would have to exercise this linear amplifier over its expected range of voltage and current (and temperature)—and make sure the ringing stays far away, as I said in Pease's Principle on page 99 of my book.<sup>1</sup>

But how about for a buzzing comparator? If you put in hysteresis, it seems okay. But how can you make sure it is going to run safely? I don't think anybody has a solid answer on this. But here is my solution: change a resistor to cut the hysteresis by about half. If it still runs safely without any oscillation or screaming as the input signal passes the threshold, that is a good indication.

So restore the proper amount of hysteresis, and you are probably safe. Unlike the amplifier problem, this is unlikely to be affected by temperature. But it is likely to be affected by layout, so don't let anybody fool around with the layout.

In the real world, those of us who have to drive with snow have learned that you have to do some practice skidding at the start of each season and every time there is significant snowfall. As I said on p. 224-246 of my other book, practice hitting the gas and the brakes too hard and cornering a little too hard in an empty parking lot and on the road, too, where snow conditions may be a lot different.<sup>2</sup> I don't have to spell that out, unless you are a new arrival to snowy territory.

**JUDGING POWER** • Next, how do you make sure you have enough power-supply bypass capacitance? I have seen a couple of analytical studies, and they have come to the same conclusion as my rule-of-thumb solution: Use one ceramic disc cap, 0.02 or 0.1  $\mu\text{F}$  per IC (on each supply, if it is an op amp with + and - supplies), and add one 2- or 10- $\mu\text{F}$  electrolytic or tantalum cap per four or five ICs. But how do you know that it's safe?

My solution is to lift out (or snip out?) half of the capacitors. Study some of the critical waveforms before and after you snip and see if the circuit seems to be okay. Study the amount of ringing on each power bus. Then, put the caps back in. Of course, some amplifiers are so slow and docile, they aren't very dependent on a lot of bypass caps. But you never know until you check it out.

Why not just leave the capacitors out? Well, you might save a dime or two. But you would lose your safety factor. You would have to do a lot more testing at hot and cold to be sure you were safe.

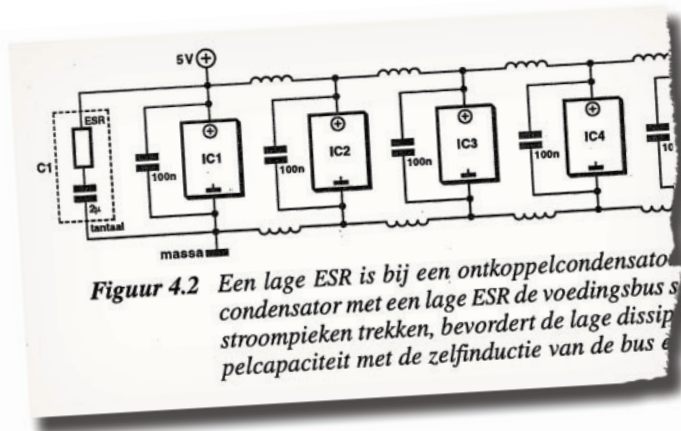

And after your electrolytics have aged, you could lose your safety factor even at room temperature.

**MORE ON FLYING** • What if you are approaching a mountain pass? "If the pass looms smaller and smaller behind the cowl, you are probably going to make it. But if the pass looms bigger and bigger, you know you are not going to make it," one pilot explained.

That may be literally true, but that doesn't sound like nearly enough safety margin for me. Several pilots said they like at least a 3000- or 5000-ft margin over the pass to allow for downdrafts.

Here in the U.S., updrafts often go up the west slope of a mountain, and downdrafts come down the east side—but not always. And altimeters usually tell the truth, but not always. So when piloting a plane, you have to have your own rules for determining what to use for a safety margin and when to trust it. 🛩

(1) *Troubleshooting Analog Circuits*, Elsevier, R. Pease, 1991, p. 99  
 (2) *How to Drive Into ACCIDENTS—and How Not to*, Pease Publishing, 1997, p. 224-246

**Comments invited!** rap@galaxy.nsc.com —or:  
 Mail Stop D2597A, National Semiconductor  
 P.O. Box 58090, Santa Clara, CA 95052-8090

**BOB PEASE** obtained a BSEE from MIT in 1961 and is Staff Scientist at National Semiconductor Corp., Santa Clara, California

**BOB PEASE** | Contributing Editor

rap@galaxy.nsc.com

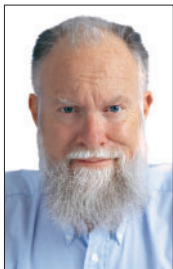

## Bob's Mailbox

**B**ob: As we were landing at O'Hare Airport last week, I was observing the runway and taxiway lighting. I immediately noticed that the lights are now LEDs. Would you believe that even these are designed to operate off the standard 6.6-A constant current system? (See [www.flightlight.com/airport-lighting/1.1/1.1.2.html](http://www.flightlight.com/airport-lighting/1.1/1.1.2.html).) This fixture is rated at only 3 W, which means it apparently drops 0.5 V at 6.6 A (perhaps 1.0 V or more with transformer losses?). There is still a power saving because they can supply the current loop from a lower voltage. *(Yeah, but the transformer makes it a game, as you have seen. And they have to be prepared to put incandescents back in—in case the LEDs get flaky. /rap)* There are two ways I could tell these were LEDs. First is the very pure blue or yellow color. But I can also instantly tell when a light source such as an LED is operating from rectified ac or pulsed dc. If you let your eyes scan from left to right, you can see a crude oscillograph view of the lights, with a dashed-line trail instead of a continuous trail, indicating a 60- or 120-Hz rectified waveform. You can also see this effect on LED car tail lights, which are apparently pulsed to dim them. I estimate the tail lights are flashing at a few hundred hertz to a kilohertz. *(Would you expect this to be audible? I'd be surprised if it didn't make an annoying buzz. /rap)* Someday I would like to build a spinning mirror device to view this more accurately.

- **Ken Lundgren**
- **Pease:** *Any simple spinning disc or light chopper could confirm this. A motor and wheel (black paper) with a notch cut into it could be much easier than a mirror to rig, or a black-and-clear plastic foil disc. I bet you could rig up an electric demodulator too, but not a big deal.*

**Dear Bob:** Seeing Christmas cards for sale in the local bookstore now gave me pause to realize that the November issues of ED are being set up. In all my many years behind the desk, only once in my 35-year career have I worked for a company that actually distributed a Christmas bonus—and even then, it wasn't cash! The better part of a decade fresh out of school was spent at Litton Aeroproducts, located near Los Angeles. Litton made inertial navigation and radio navigation equipment for a vast majority of the world's airlines. An occasional customer of Litton Aero was Lot Polish airline, the state-owned airline of Poland, then under a loose Communist rule. I don't recall all the legalities (and perhaps behind-the-scenes maneuvering) that went on, as I was just a design wonk. But I do recall that because of some trade restraints, it was illegal to accept cash from Poland. The average cost of an inertial nav system at the time was somewhere in the neighborhood of \$85,000, maybe more. What Lot Polish did was to pay Litton in ham. Yes, the little-piggy-that-could kind. You could tell when LP bought something, as perhaps a half-dozen refriger-

ated trailers would show up in the parking lot—and always, it seemed around the end of December. And so, with your paycheck, you would receive a stub in the same envelope that would grant you one ham. If you didn't eat ham, you could have the stub exchanged for a voucher for a 10-lb turkey from the local supermarket. Litton is gone and never did any profit sharing, but it makes me wonder what our share would be—ham steak?

- **Karl Strauss**
- **Pease:** *Hi, Karl. That is funny!*

**Hi Bob:** I had to chuckle when your correspondent first wrote about filling the oil lamp well ("*Bob's Mailbox*," Sept. 1, p. 18), since I'd been mulling over the possibilities of detecting the water level in my 280-ft drilled well on a real-time basis by either organ-pipe-like resonance or acoustic time of flight. (Water can come as close to the surface as 30 ft, according to the label placed on the wellhead by the driller in 1994. Or to be more precise, 30 ft is listed as the "static water level.") *(Either of your schemes would work okay, presuming there is enough accuracy in each range to suit your needs. My scheme with a capacitance detector between adjacent wires might work, too. /rap)* But considering the original problem, isn't the use of a self-heated thermistor a standard, quite low-tech solution? *(It might work, but it will not give you a gradual indication of when you are approaching the stop point, will it? Besides, if a little of the in-pouring oil splashed onto the thermistor, it will cool off, not so? So it would give a false reading. Would you be able to hide the thermistor so incoming oil would not hit it? Maybe, but life ain't as simple as it seems! /rap)* Didn't 100 people suggest this? *(No, thank heavens! /rap)* Placing the thermistor in a 555 timer circuit driving a small loudspeaker would be my approach—no need to look at an indicator. *(Will a 555 drive a thermistor in a self-heating mode? Maybe so. /rap)* Digikey has tiny brick-shaped thermistors with millimetric dimensions and dissipation constants in air of 1 mW/°C for less than a quarter.

- **Jim Hayden**
- **Pease:** *Maybe your idea would lead to a good solution. Hey, put two thermistors in parallel (or in series?). The first inflection tells you to slow down, and the second tells you "Stop!" Go ahead and build it and send it in as an Idea for Design. If you put them in a 0.25-in. ID tube, properly vented at top and bottom, they could detect the rise of fluid and avoid splashes of incoming oil.*

**Comments invited!** [rap@galaxy.nsc.com](mailto:rap@galaxy.nsc.com) —or:  
Mail Stop D2597A, National Semiconductor  
P.O. Box 58090, Santa Clara, CA 95052-8090

**BOB PEASE** obtained a BSEE from MIT in 1961 and is Staff Scientist at National Semiconductor Corp., Santa Clara, California.

**BOB PEASE** | Contributing Editor

rap@galaxy.nsc.com



## What's All This Stability Stuff, Anyhow?

A guy recently asked me how I would look for a voltage reference that's stable versus temp cycling. I told him I would take several of the best voltage references I had and use a dual-slope DVM of at least six digits to compare them to the units in question. He then asked if comparing some

references to some other ones was kind of incestuous. This is not rocket science.

You take several good voltage references and leave them the heck alone! Apply some bias and just let them run undisturbed. I have done this many times. But if possible, measure each of them, at least once or twice per day. Gather up the trends. Look at the data. Study them, study the standards, and study the DUTs.

I once had a set of 16 good references, LM399-types, that had a subsurface (buried) zener and a heater to hold them at 88°C. Each output was 6.9 V ±2%, and I averaged the output through some 499-Ω resistors. The output impedance was 65 Ω. I measured the average of eight versus eight. The relative stability seemed to be very good. The noise seemed to be excellent—better than 0.1 ppm p-p, out of 7 V, in a bandwidth of about 1 Hz.

But the point is that if you leave something alone, and cycle something else through experiences, you learn something. What are you trying to learn? A drift versus temp is easy to spot if one part goes through a temp cycle and another doesn't.

Cycle the DUTs twice or four or eight times. Look for trends. Check the  $V_{REF}$  of each of these against the average of the two or four or eight uncycled references. You may learn something. What do you see for trends? Do you see a drift that decreases gradually versus experience? Or is there some hysteretic drift that keeps coming back?

**BACK IN THE DAY** • Back 24 years ago, we set up some excellent long-term stability tests for the LM199AH. We read their data every week for six weeks, compared to a battery of other reference voltages, including ovenized saturated standard cells,  $4 \times 1.018$  V dc. We convinced ourselves that these references were mostly drifting less than 10 or 15 ppm per 1000 hours.

We sold them with a guarantee of 20 ppm per 1000 hours. When we ran out of such customers, we shut down that aging/testing program. But it was challenging. What if one or more of the tested references had some drift? We were prepared to use our judgement to decide that the apparent drift of one reference could be ignored—if all the other references seemed stable.

What if the DVM's reference started drifting? This was a ratio-metric test, so we could correct for that. So long as most of the references seemed stable, we could compensate. Of course, we had to rely on the ratio-metric linearity of the DVM, which was guaranteed and inherent, better than 1 ppm. It was a very good HP3456.

To be fair, I shouldn't just call it a dual-slope DVM. It was more like quad slope or multi-slope. Its measurement scheme used a lot of rubbing and polishing. I have seen several other kinds of six-digit DVMs that had linearity flaws, but the Hewlett-Packard ones never showed any such error. Now they are called Agilent.

Since that era, we have used groups of LM399s as references for testing other kinds of band-gap references. Of course, using a group of four references can increase the chances that one of the group will start drifting.

But if you have four groups of four, the chances that one will start drifting and won't be apprehended are quite small. Long-term drift can be fairly dependable. We sent some LM399s to the NBS/NIST, which found a long-term drift rate of about 1 ppm per 1000 hours when the die was self-heated to 88°C.

Other people have observed that if the LM399 isn't heated to 88°C, but just kept at room temp, the long-term drift rate can be less than 1 ppm per 1000 hours. So should you heat them up only an hour per month? Maybe so.

The  $V_{OS}$  of an op amp is almost trivial—and it is not trivial, nor is it trivial to guess, what will happen on the next full temp cycle. Sometimes an op amp will drift 1 or 2 μV. But other times it may drift 3 or -4 μV after cycling around a full set of temperature tests. The next time it goes around the cycle, it might drift 4 or -3 μV. This is due to stress on the die. Can you predict this? I don't think so. So even an op amp requires some respect in its testing.

A computer can predict how much stress will be on the first die, at various places, when it is packaged. It can predict how much stress will be on the second die—and the third. It's all the same. So offsets and drift and hysteresis will be the same, right? Not so. So much for computers. So much for CAD. I prefer to admit the reality of computer-hindered design.

These stresses apply also to band-gap references. They, too, have drifts as they are temp-cycled and brought back to the original temperature. I don't know any circuits that aren't more stable if you just leave them alone. ☹

*Comments invited! rap@galaxy.nsc.com —or: Mail Stop D2597A, National Semiconductor P.O. Box 58090, Santa Clara, CA 95052-8090*

**BOB PEASE** obtained a BSEE from MIT in 1961 and is Staff Scientist at National Semiconductor Corp., Santa Clara, California

**BOB PEASE** | Contributing Editor

rap@galaxy.nsc.com



## Bob's Mailbox

**B**ob: In “What’s All This Capacitor Leakage Stuff, Anyhow?” (March 29, 2007, ED Online 15116) you have a diagram of a test circuit using the LMC662. This circuit is quite a bit different from the “capacitor soakage” test circuit you referenced on your Web site. (After you get the capacitor charged up, and after you get the soakage elements charged up (which takes hours and days), the rate of change of  $V_{OUT}$  is caused by the leakage, which you cannot really see until you have waited some days. Any rate of change before that is mostly caused by soakage. So in this experiment, I was trying to separate the soakage from the leakage. After a few days, this did work right. For a soakage test, try charging up high first and then pulling it to ground. The leakage is not involved. /rap) For the leakage circuit, I was curious what the “ball hook” and the coax were for. What’s that all about? (The ball hook lets me connect to several different capacitors in sequence. It is insulated with cheap nylon. That isn’t a very good low-leakage insulator, but if I keep my body biased up to 8.8 V, it is not too bad. /rap) Why is the coax 12 in. long? (I’m guessing it could be shorter but not a lot longer.) I figured the ball hook is the same as what I call a “chicken stick.” We hams use them when working on high-voltage circuits to make sure all the caps are for sure discharged by grounding the chicken stick with a clamp to chassis, then running the “ball-hook end” over all of the high-voltage components. (Yeah, but when you use the chicken stick, do you put it in series with 1  $\Omega$ ? Or 0.1  $\Omega$ ? How often does the 1- $\Omega$  resistor have to be replaced because you blew it out? I am not working at low-ohms levels, but at 10 to 100 M $\Omega$ . Different range, eh? By 13+ orders of magnitude. I hope that you have learned that even your chicken stick can not discharge a big high-voltage oil capacitor properly because it can recharge itself up to hundreds of volts due to soakage if you wait a while. A big high-voltage cap needs a resistor to discharge it for a long time to make it stay at low voltage, not just for a second. Over near Livermore, some movers were moving some big high-voltage capacitors. One crate got busted, the shorting bar got knocked off the capacitor, and a moving guy bumped into it and got killed—electrocuted—even though the capacitor must have been shorted out for hours! Dangerous things. /rap) Here, you’re probably using it to prevent distorting the experiment through human-body discharge. (Yeah, it is an adequate insulator. It seems to have less than 2 pF of capacitance and 1 lousy M $\Omega$ . If I had a Teflon ball hook, that would be nice. But the ordinary nylon one is okay. I don’t need perfection. I can get good measurements if it is just good enough for a short time. /rap) Just curious about the specifics with the coax. (Even though I could not see it, I remember that the coax was to prevent leakage into the + input. It had to be at least 12 in. long to reach all the capacitors. If I had a bigger array of capacitors, I could have used 2 or 3 ft of coax to reach them. No big deal. /rap) This looks

like a fun little project. Have you done any more work on it since?

- **Jason A. Dugas**
- **Pease:** No, but I will next week.

**Bob:** A year ago you had an article on the Sallen-Key filter (Sept. 28, 2006, ED Online 13480). In that article, you mentioned that using an op amp with higher input impedance will allow the use of larger values of R1 and R2 and smaller, cheaper, and higher-quality capacitors. What is the tradeoff of staying with smaller R1 and R2 values to reduce Johnson noise and having to use X7R caps instead of NPO caps? To use all NPO caps in my four-pole, two-op-amp design, I must cross over the 1-M $\Omega$  level for some R values.

- **Bruce Allen**
- **Pease:** What BW are you trying to handle? Low pass or high pass? If you used 0.01- $\mu$ F NPOs and 1 M $\Omega$ , you would be talking 16 Hz. A 1-M $\Omega$  resistor doesn’t have much noise in a 16-Hz bandwidth. It would have (125 nV  $\times$  4) rms or 3  $\mu$ V p-p. Most op amps have more noise than that. These days, you can buy NPOs bigger than 0.02  $\mu$ F. Look in Digikey. You ought to build it and try it both ways. Avoid X7Rs, which have long soakage tails.

**Hi Bob:** Nikola Tesla was an amazing man. He is now credited as the inventor of the induction motor, wireless transmission, Tesla coil, logic gates, Tesla turbines, lighting ionizing gases, etc. (No argument. His induction motors and several other items were quite brilliant. /rap) I’m most interested in his claims of wireless transmission of power. If anyone could have pulled this off, he was capable of doing it. He invested a lot of his time and money in this endeavor, only to fall through by being under-budgeted. (I think he was over-ambitious with schemes that could not possibly work. Some of his schemes were loony, and even Tesla couldn’t make them work. /rap) I think we are just coming to grips with what he knew. He knew the Earth’s capacitance and telluric currents, resonance, distance of the ionosphere, the difference between transverse and longitudinal waves, etc. What is your opinion on this? In general, do you think it’s possible? Do you have any technical insights?

- **Tony A. Wittic**
- **Pease:** I am not 1/20 as smart as he was when he had his head screwed on right, because I am not an electric field expert. I’m just dumb. That’s okay. When he had nutball ideas, which he often did later in life, he may have been dumber than me.

**Comments invited!** rap@galaxy.nsc.com —or:  
Mail Stop D2597A, National Semiconductor  
P.O. Box 58090, Santa Clara, CA 95052-8090

**BOB PEASE** obtained a BSEE from MIT in 1961 and is Staff Scientist at National Semiconductor Corp., Santa Clara, California.



# WHAT'S ALL THIS "BEST TRICK CIRCUIT" STUFF, ANYHOW?

**Bob Pease**  
CONTRIBUTING EDITOR

Once upon a time, op amps didn't swing very close to the positive or negative rails. Even a couple volts away from the rails—that was okay in the old days of transistor-ized op amps.

Hey, that was a lot better than with vacuum-tube op amps that wouldn't swing within 200 V of the rail. Some op amps could do a little better, but customers never asked us for better 35 years ago.

The LM324 can swing pretty close to ground ( $-V_S$ ) if you have a pull-down resistor—or close to  $+V_S$  if you have a pull-up resistor. But, of course, it has a pretty big (ac) dead zone when driving its output. Crude. Slow.

Many modern low-voltage op amps have common-drain outputs. This is often called a "rail-to-rail" output, even though it won't really go *to* the rail. Martin Giles always razzes me (quite properly) if I talk about these amplifiers as "rail-to-rail."

Widlar's 1976 LM10 was the first to have a common-collector "rail-to-rail" output, swinging within a few millivolts of each rail. Most CMOS op amps don't swing that close. If you have an op amp running on "+5 V dc," it surely can't swing to even +4.9 V if its power supply is only +4.75 V (i.e., if the supply has a 5% tolerance).

So if you have an analog-to-digital converter (ADC) with a 2.5-V reference, and a 2.5-V full scale, an op amp running on +4.75 V can easily swing up to

the + full scale at +2.50 V. But it still can't swing that close to ground. Even for a 10-bit ADC, you are going to lose a few least significant bits where the amplifier can't swing low enough (Fig. 1). The output may swing within 12 or 22 mV of ground, but not closer.

The trick is to add a high-impedance diode from (a) pointing to (b), replacing the hard wire. (1N4004, not 1N914). Even if the amplifier's output can't swing within 100 mV of ground, it doesn't have to. To get the output to within 0.1 mV of ground, the diode leakage merely has to go down to 50 nA at  $V_F = 0.1$  V, even at your highest operating temperature. Even at 95°C, you can do this with a transistor's C-B diode. Try it.

The ~2k pull-down resistor in shunt of the output and the diode in series with the op amp's output make the trick work. It can drive the high-impedance input of an ADC within a small number of microvolts of ground—much better than a "rail-to-rail" that can only get within a small number of millivolts of ground.

So the circuit of Figure 1 can swing close to ground nicely, but not close to the positive rail. Is that what you needed, bunky? Why didn't you say so? Try Figure 2. Install one high-impedance diode from (c) toward (d) and another one anti-parallel.

The 74C14 has a lot of "gain," but not a lot of output offset—and very little power drain in this switching mode. I have seen it drive an ADC within a few microvolts of both rails.

One of the advantages is that it won't over-drive the input of the ADC past the rails. Good feature.

These circuits are not very fast, and not low-distortion, and they won't drive much of a dc load. Do you want to drive a dc load? If we add another trick, you can drive a load. Go to [www.national.com/rap](http://www.national.com/rap) and click on "rail-to-rail driver." Have fun!

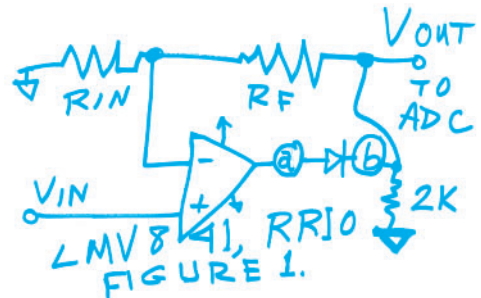

**SCHOOL DAYS** • When I was a kid engineer of 18 at MIT, I took course 6.021 on Piecewise Linear Circuits with graduate instructor Leonard Kleinrock. I learned a lot from him.

Now, Prof. Kleinrock is a respected professor at UCLA and one of the inventors of the networks leading to the formation of the Internet. AND 49 YEARS OUT, I AM STILL HAVING FUN DESIGNING PIECEWISE LINEAR CIRCUITS! I hope that Lenny is still having fun, too!

**BEST NEW RECIPE** • For an excellent casserole, boil 1 lb white beans (~Great Northern) in 8 cups H<sub>2</sub>O, 3 minutes; let stand 2 hours, then simmer an hour. Meanwhile, bake ~2.5 lb of pork roast at 350°F. Cut into 1/3-in. cubes; discard most chunks of fat. Scrub potatoes and cut into 1/4-in. cubes to make 2 cups. Add pork and potato to the beans. Add a 4-oz can of warm or hot chopped chilis, to taste, and one (or two) (or 1/3, if you are trying to not scare the kids) 4-oz cans of hot chilis, chopped fine (3/16 in.). Add salt and pepper to taste; simmer 1/2 hour. RAP invented this Best Recipe of the year: I had a hunch, and it worked out well. ☺

**Comments invited!**  
[rap@galaxy.nsc.com](mailto:rap@galaxy.nsc.com), or  
Mail Stop D2597A  
National Semiconductor  
P.O. Box 58090  
Santa Clara, CA 95052-8090

**BOB PEASE** obtained a BSEE from MIT in 1961 and is Staff Scientist at National Semiconductor Corp., Santa Clara, California.

**ED ONLINE 17601**

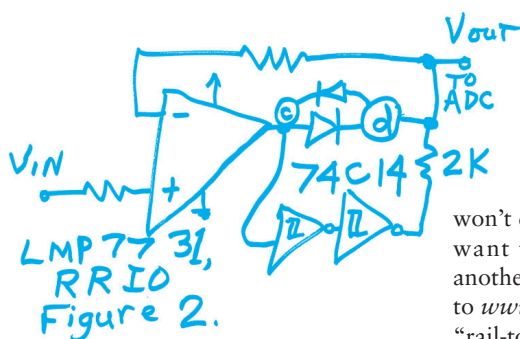

**BOB PEASE** | Contributing Editor

rap@galaxy.nsc.com



## Bob's Mailbox

**B**ob: While my full-time job is writing for *Electronic Design*, I still teach part-time and work on an NSF grant that is attempting to update the electronics curricula in community colleges. From my observations in my own college and across the country, most curricula are out of date with what is going on in the industry. *(True, but not disastrously bad. We can't ask that education for techs or for EEs be really up to date. That has almost always been impossible. /rap)* There is too much emphasis on BJTs and little or poor coverage of MOSFETs and ICs. *(Yeah, but you can get and buy and solder BJTs, and the circuits will work. You can't get MOSFET kit parts worth crap! And if you do, they don't work well. In most cases, even Spice works better than making breadboards of MOSFETs. Of course, we know the exceptions... If a kid has learned a little about MOSFETs and a lot about BJTs, we can convert him over. /rap)* I would love to get your opinion. Could you answer a few questions? First, what would you say the percentage mix of BJT/MOSFET circuits is in ICs (or discretes) for linear and digital? It must be close to 100% digital, but what about linear? *(I think it is about 45/55, but we work on weird projects. Many people do not recognize that to make low-power circuits, CMOS is not inherently low-power. It takes a lot of work. So, we make micropower op amps using BJTs—and very fast ones, too. When you go that fast, you have to trust Spice, somewhat. /rap)* Second, have you seen any engineering techs recently? And does NSC employ them? *(Yes and yes. I have interviewed some and lectured to some recently. /rap)* These are the guys that help engineers with breadboarding, test, etc. I haven't seen many in years, although I used to be one. (I actually repaired Philbrick K2Ws and related gear way back years ago.) What is your take on this? *(Our technicians can repair ANYTHING—yes, even K2Ws. (I still have some and use them.) /rap)* Third, how important is it for a tech to know detailed BJT and MOSFET biasing, etc.? *(Generally, not. Biasing FETs is almost impossible because a good bias depends on the match of the FETs, and that happens well on only one chip. /rap)* Fourth, most of us working on the NSF grant think that a tech needs more of a systems view today as opposed to a detailed circuit-analysis background. Do you concur?

• **Louis E. Frenzel, Communications/Test Editor**

• **Pease:** *I tend to agree. Often, a good technician must use and understand op amps—and measuring equipment, DVMs, spectrum analyzers, and automated test equipment. Circuit analysis is a specialty, and even for engineers, this is challenging. Of course, they should be aware of circuit analysis and bias setup. Even 20 and 40 years ago, we did not demand them to be experts at that. We're now asking our senior techs to do more and more analysis of data and to tell us when things look right—and when things look suspicious or "funny." They're usually quite good. Of course, we've had the luxury of several excellent techs*

*out of the College of San Mateo, and with just a few years of mentoring, many of them have become circuit engineers.*

**Dear Bob:** Your article "What's All This Input Impedance Stuff, Anyhow?" (Sept. 7, 2004, *ED Online* 8576) describes a single op-amp differential amplifier circuit with a gain of 100; resistor pairs of  $R_1 = 1k$  and  $R_2 = 100k$ ; and front-end buffers ignored. I do not argue about circuit gains of voltages. They seem to be okay. But the impedances are not. Various sources (like NS's Linear Application Handbook: AN-20, AN-29, etc.) state that the input impedance of the circuit at the inverting input is equal to  $R_1$ . I do not accept this unconditional statement! When inputs are equal and in opposite phase, as in an ideal case, the input impedance is actually  $500 \Omega$ . *(Ah, but that is a special condition! /rap)* In your article, the impedance is claimed to be  $R_1 = 1k$  (according to the handbook statement), which is incorrect. When inputs are driven to 10 V dc each, the impedances are 101k on both sides, just as in your article. I agree. But this 101k impedance is not equal to  $R_1 = 1k$ . If gain = 1 (all four resistors equal), then impedance is  $2/3 * R$ . I argued about this with Dr. Michael Ellis a few years ago, and after some calculations and simulations, we agreed. (First, I was wrong when believing the unconditional statement above.) But when the input voltages are not equal, the situation changes further. For example, if positive input is 100 times negative input and in opposite phase (gain = 1 circuit), then the impedance is only  $1/50 * R$ . You may simulate various conditions as I did and find out that the impedance varies vastly. *(Well, if you pick the right "special conditions," anything can happen! /rap)* Obviously, we must come to the conclusion that the impedance at the inverting input node is not equal to 1, neither constant, but depends on magnitudes and phases of input voltages and is therefore largely variable. In general, when inputs are not correlated with amplitude or phase (random input or noise), one can not guess the impedance. Do you agree?

• **Eero-Pekka Mand**

• **Pease:** *I tend to agree. But (a) there is nothing simple about this, and (b) you have waited three years to comment! So (c), shall we consider the case where the input is a transformer winding, not center-tapped? Or (d) cap-coupled? If the caps are big enough, it may still work. But you may need 100X bigger capacitors on the negative input. Let's discuss. This might lead to "What's All This Z In Stuff, Anyhow? (Revisited)."*

**Comments invited!** rap@galaxy.nsc.com —or:  
Mail Stop D2597A, National Semiconductor  
P.O. Box 58090, Santa Clara, CA 95052-8090

**BOB PEASE** obtained a BSEE from MIT in 1961 and is Staff Scientist at National Semiconductor Corp., Santa Clara, California.