

Commodore 1902A Repair



Figure 1: Commodore 1902A 14" CRT Monitor

1 Overview

The goal is to repair an old Commodore CRT monitor. This is not a computer monitor, but a strange hybrid TV/Commodore only mode CRT. Normal CRTs take input of RGB, while this one takes composite video (like a television), as well as RGBI¹. This particular monitor, the 1902A has three inputs. One for composite, one for S-Video (essentially connected to same circuitry as composite) and one for RGBI mode.

Currently, the monitor has errors on composite input / S-video. There are no errors on the RGBI input.

¹This is one of the things I learned here, the difference between a computer monitor and a television. TVs take in NTSC/PAL/SECAM analog video. Computer monitors take in the signals already split up (VGA). However, this monitor does a hybrid of both, being made before VGA was commonplace.

Contents

1 Overview	1
2 Work Log	2
2.1 We require more resources... (Starcraft 2 reference)	2
2.2 Errors on the Schematic	4
2.3 Getting the Monitor ready for the repair attempt	6
3 References	6

2 Work Log

I picked up an old HP TV service manual (6945A) for this project. I am not knowledgeable about televisions, but the more I read, the more I think I can handle this. I have also the manual for the monitor, though it is quite a bit sparse, comparably.

Quite a bit of the Commodore 1902A TV circuitry (H sync, V sync, etc) is in a few ICs, according to the schematic.

The waveforms in the Commodore manual were created with a (standard?) NTSC test signal, the **10 bar gated rainbow pattern signal**. I am currently researching how to generate that myself, without forking out the cash for a video tester (Cheapest I saw the other day was \$70. I wouldn't pay more than \$20.

From a brief search, most people have only setup rough test signals with uCs that do either NTSC or PAL, but not necessarily the full 10 bar gated test signal. Instead only a passable working signal, to verify video output, seems to be par for the course. I might be out of luck!

2.1 We require more resources... (Starcraft 2 reference)

I reviewed this page:

<http://www.repairfaq.org/sam/monfaq.htm#monsugref>

Which many will recognize as the gargantuan repair faq website.² I'm going

²I find text heavy websites like this, quite incomprehensible, to be honest. How much better the site would be, if it was a book. I know I'm not the only one that thinks this way

to purchase a book they mention:

Computer Monitor Troubleshooting and Repair - Joe Desposito and Kevin Garabedian

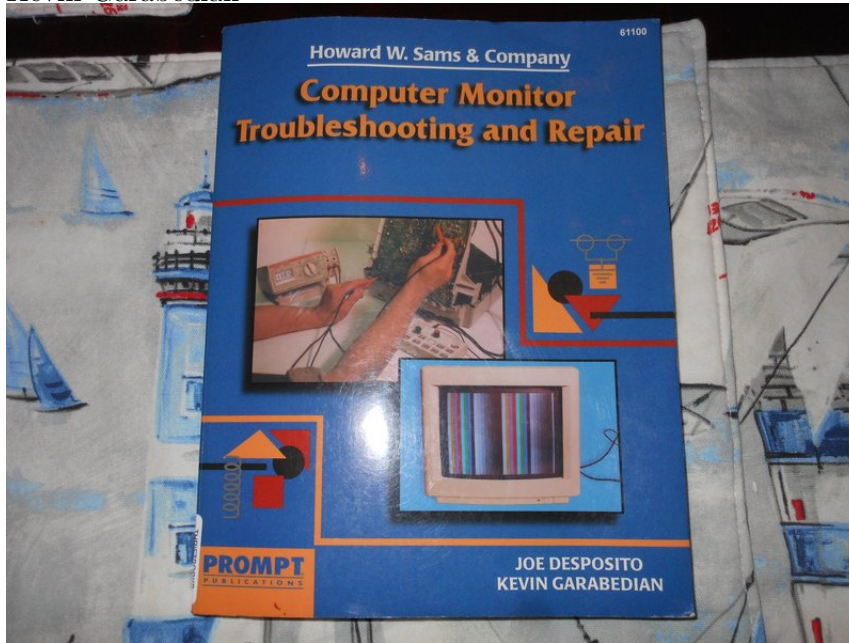

Figure 2: Computer Monitor Troubleshooting and Repair which cost me a whole \$6.00 from a used book store online. While the HP book was helpful, it is for a B&W CRT lacking any colour related circuitry, and I need something with more practical repair advice. The HP tech book, is also dry, which means it assumes you understand a lot of the mechanics already.

After reading about 80 pages of the computer monitor repair book (recommended as I said by repairfaq.org) I can say it is a good book, and would recommend it to others. it lacks any concrete material on TV Signal encode/decoding, it being a book on computer monitors (which have RGB signals split up by default, via the VGA connector), it remains a straightforward and down to earth book on CRTs. An obsolete gem.

Here's an example page, for those readers interested in a preview:

(e.g. Bill Waterson said he prefers actual paper of his comics to a computer screen), but yet websites continually seem to post article after article, after blogpost, after blogpost, of which I will not take the time to click through. Websites are infinitely inferior to books, for any significant amount of text. This is why twitter (and not booker) is so successful. Am I wrong in thinking this, or are the search engines skewing how much people actually read these "blog" websites?

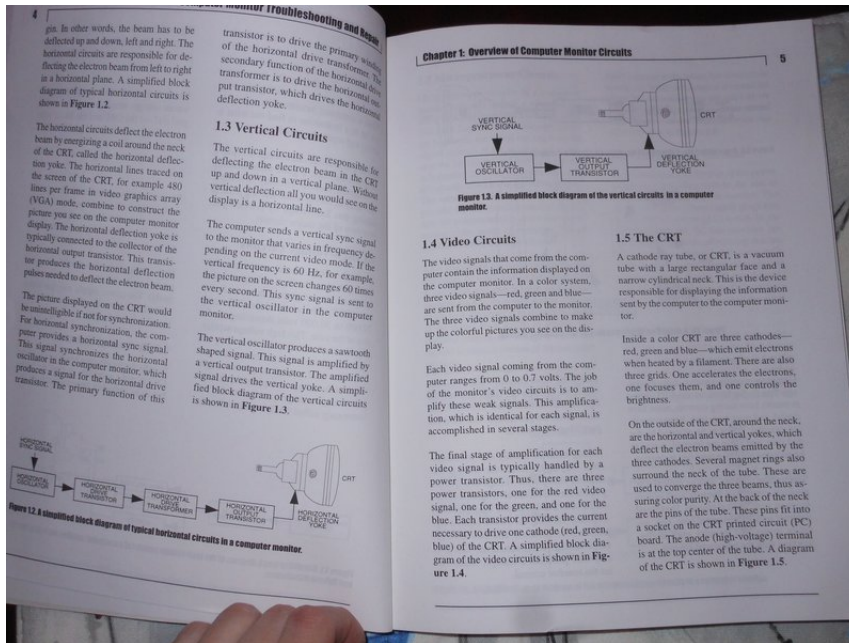

Figure 3: Second Page. Right from the start the book is easy to read and approachable.

2.2 Errors on the Schematic

After reviewing the Commodore 1902A service manual, I noticed that the layout design doesn't match up 1:1 with the schematic... On the same service manual! Is this an honest mistake, or a reluctance to give repairmen the real schematic, or a limitation of time and money? Who knows. In any case, I found an initial error looking at the early Composite signal input.

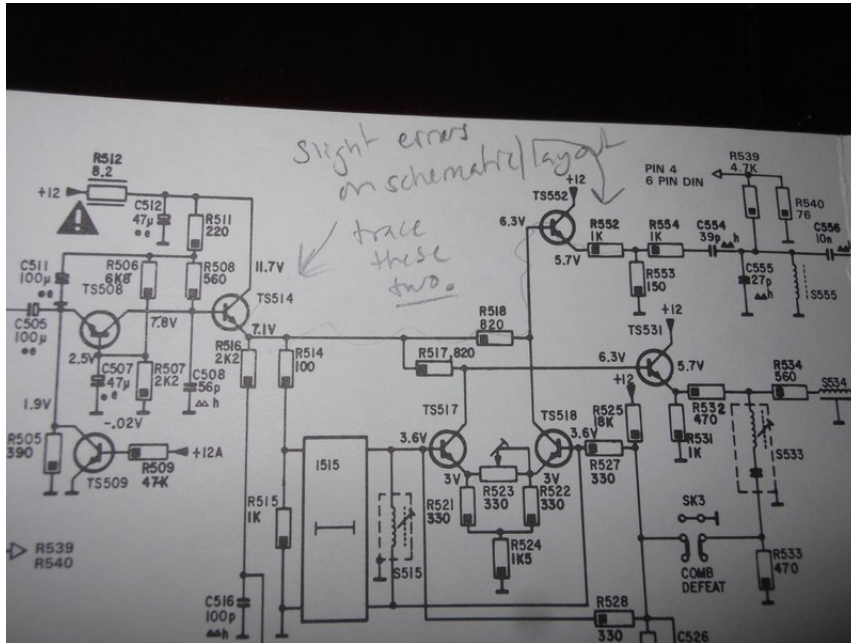

Figure 4: Schematic lists ICs with numbers that...

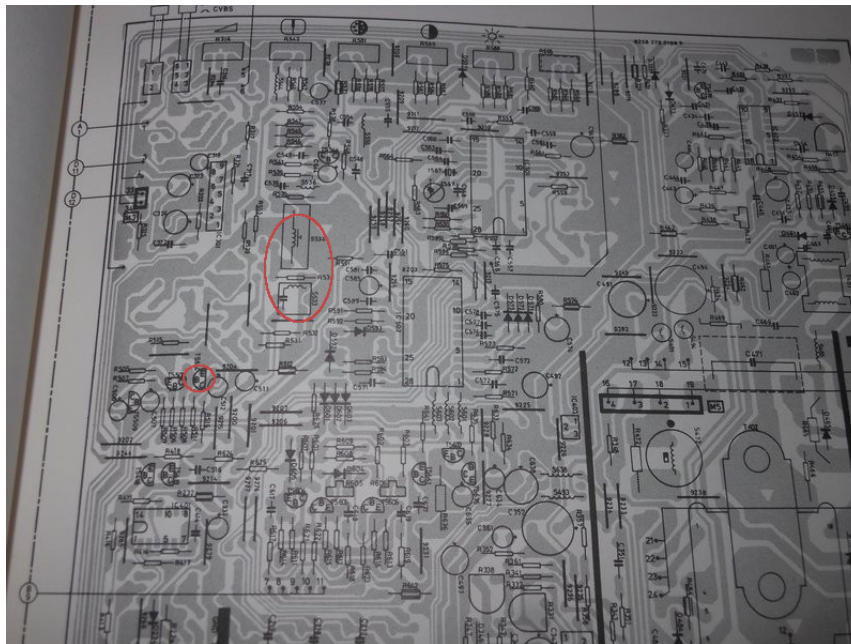

Figure 5: Differ on the actual layout diagram. Repairman beware!

2.3 Getting the Monitor ready for the repair attempt

I setup the monitor on the bench this evening, desoldering the can on the bottom, and resoldering on of the hi voltage wires I had to cut in order to disassemble it. The pictures I took helped a lot in finding where everything went. In particular there are two ground pins that are easily confused. One is for the high voltage area, the other for the CRT board.

Reviewing the schematic, I traced out a bit more of what goes where, and will start by checking the voltage levels. But first, to get a signal source.

Like the Sony PVM³ I've taken apart and attempted to repair previously, this CRT is not easy to service. Accessing the bottom of the board while it's powered on is a balancing act.

3 References

Books

- Art of Electronics 3rd Edition (Horowitz, Hill): Appendix I - Television.
- Computer Monitor Troubleshooting and Repair - Joe Desposito and Kevin Garabedian

Video⁴

- Retro Game Mechanics Explained: https://www.youtube.com/channel/UCwRqWnW5ZkVaP_lZF7caZ-g (the SNES section has some well produced CRT video explanations).

³Sony PVMs are a brand of television that retro video game players make a big fuss about (circa 2010's). To be honest, I have 2 of them, and I don't find them worth the hype. Especially not RGB mode. Any modest CRT was good enough when you were a kid, and any modest CRT is good enough as an adult. It's the gameplay that matters. Don't believe the hype!

⁴Disclaimer: Youtube is bad. Please avoid when possible in favor of a video site that is not a centralized, censored, monopoly.